

# SERVICE MANUAL



**DAYSTAR**

## How to use this manual

This manual explains how to maintain the Daystar of the DAELIM MOTOR CO., LTD.

Follow the maintenance schedule (Section 3) recommendations to ensure that the vehicle is in peak operating condition.

Section 1 through 3 apply to the whole motorcycle, while sections 4 through 18 describe parts of the motorcycle, grouped according to location.

Most sections start with an assembly or system illustration, service information and trouble shooting for the section. The subsequent pages give detailed procedures.

If you don't know the source of the trouble, go to section 20, trouble shooting.

All information, illustrations, directions and specifications included in this publication are based on the latest product information available at the time of approval for printing.

DAELIM reserves the right to make changes at any time without notice and without incurring any obligation whatever.

No part of this publication may be reproduced without written permission.

Some drawings of this manual can be slightly different from actual specification of model.

## Contents

General	General Information	1
	Lubrication	2
	Maintenance	3
Engine	Fuel System	4
	Engine Removal / Installation	5
	Clutch / Gearshift	6
	A.C. Generator / Starter Clutch	7
	Cylinder Head / Valve	8
	Cylinder / Piston	9
	Crankcase / Transmission Crankshaft / Kick- Starter	10
	Cooling System	11
Frame	Seat / Exhaust Muffler	12
	Front Wheel / Front Fork / Steering	13
	Rear Wheel / Rear Brake / Suspension	14
	Hydraulic Brake	15
Electrical	Charging System / Battery	16
	Ignition System	17
	Electric Starter	18
	Lights / Switches / Horn	19
	Wiring diagram	20
	Troubleshooting	21

# 1. General Information

<b>General Safety</b> .....	<b>1-1</b>	<b>Torque Values</b> .....	<b>1-5</b>
<b>Service Rules</b> .....	<b>1-1</b>	<b>Safety Notice</b> .....	<b>1-7</b>
<b>Model Identification</b> .....	<b>1-2</b>	<b>Tools / Tester gauge / Valve Seat Cut</b> ...	<b>1-8</b>
<b>Specification</b> .....	<b>1-3</b>	<b>Cable &amp; Harness Routing</b> .....	<b>1-10</b>

## General Safety

**⚠ WARNING**

1. If the engine must be running to do some work, make sure the area is well-ventilated. Never run the engine in an enclosed area. The exhaust contains poisonous carbon monoxide gas that may cause loss of consciousness and lead to death.
2. The battery contains sulfuric acid(electrolyte) Contact with skin or eyes may cause severe burns. Wear protective clothing and a face shield. If electrolyte gets on your skin, flush with water. If electrolyte gets on your eyes, flush with water and call physician. Electrolyte is poisonous. Keep out of reach of children.
3. Gasoline is extremely flammable and is explosive under certain conditions. Work in a well ventilated area with the engine stopped. Do not smoke or allow flames or sparks in your working area.
4. Used engine oil may cause skin cancer if repeatedly left in contact with the skin for prolonged period. Although this is unlikely unless you handle used oil on a daily basis, it is still advisable to thoroughly wash your hands with soap and water as soon as possible after handling used oil.

## Service Rules

1. Use genuine DAELIM or DAELIM recommended parts and lubricants or their equivalents.
2. Use the special tools designed for this product.
3. Install new gaskets, o-ring, piston pins, clips, cotter pins, etc. When reassembling.
4. When tightening a series of bolt or nuts, begin with the larger-diameter of inner bolts first, and tighten to the specified torque diagonally, in incremental steps unless a particular sequence is specified.
5. Use only metric tools when servicing this motorcycle. Metric bolts, nuts, and screws are not interchangeable with English fasteners.
6. Clean parts in cleaning solvent upon disassembly. Remove the cleanser with compressed air.
7. Lubricate any sliding surface before reassembly with recommended grease.
8. After reassembly, check all parts for proper installation and operation.

## Model Identification



Frame No



Engine No

## Specifications

Item		Specifications
Dimensions	Overall Length	2,240mm
	Overall Width	860mm
	Overall Height	1,140mm
	Wheel Base	1,505mm
	Seat Height	720mm
	Ground clearance	135mm
	Dry Weight	147.5kgf
	Curb Weight	341kgf
Frame	Type	Double Cradle
	Front Suspension Stroke	Telescopic fork 140mm
	Rear Suspension Stroke	Swingarm 35mm
	Front Tire Size	90/90 - 18 (Tubeless)
	Rear Tire Size	130/90 - 15 (Tubeless)
	Tire Pressure 1 Person Front	2.00kgf/cm <sup>2</sup> (200kPa)
	Rear	2.00kgf/cm <sup>2</sup> (200kPa)
	2 Person Front	2.00kgf/cm <sup>2</sup> (200kPa)
	Rear	2.00kgf/cm <sup>2</sup> (200kPa)
	Front Brake	Hydraulic Disk
	Rear Brake	Drum Brake
	Fuel Capacity	17.3 l
	Fuel Reserve Capacity	2.9 l
	Caster Angle	32°
Trail Length	147mm	
Front Fork Oil Capacity	280cm <sup>3</sup>	
Engine	Type	Oil / Air Cooled 4-stroke SOHC Engine
	Cylinder Number, arrangement	1 Cylinder, 15°
	Bore and Stroke	56.5 X 49.5mm
	Displacement	124.1cm <sup>3</sup>
	Comparison Ratio	11.5:1
	Valve Train	SOHC Chain Drive
	Oil Capacity	1.2 l After Disassembly 1.15 l After Draining and Oil Filter Change 1.1 l After Draining
	Lubrication System	Forced Pressure Splash Type
	Air Cleaner	Viscose Oil Wet Filter
	Cylinder compression	14kgf/cm <sup>2</sup> (550rpm)
	Intake Value Opens	6° BTDC
	Closes	22° ABDC at 1.12mm Lift
	Exhaust Value Opens	24° BBDC
	Closes	4° BTDC at 1.12mm Life
	Valve Clearance Intake	0.12 ± 0.02mm(0.005 ± 0.001 in)
	(a cooling-off period) Exhaust	0.12 ± 0.02mm(0.005 ± 0.001 in)
	Engine Dry Weight	32.3kg

## General Information

Item		Specifications
Carburetor	Carburetor Type Setting Mark Main Jet Slow Jet Pilot Screw Initial Setting Float level Idle Speed	Piston Valve VL125 <b>B</b> #102 #38 2 1/4 19mm 1,400 ± 100(rpm)
Drive Train	Clutch Transmission Type Primary Reduction Secondary Reduction Gear Ratio 1st 2nd 3rd 4th 5th Gearshift Pattern	Hydraulic, Multi-plate Constant Mesh Transmission 3.650(73/20) 3,000(42/14) 3.083(37/12) 1.882(32/17) 1.380(29/21) 1.095(23/21) 0.923(24/26) Left foot operated return system 1-N-2-3-4-5
Electrical	Ignition Ignition Timing "F" Mark Full Advance  Battery Capacity Spark Plug Spark Plug Gap Fuse Capacity Starting System Headlight Winker Tail/Stop Lights Meter Light Neutral Indicator Lamp High Beam Pilot Lamp	CDI Ignition 8° BTDC / 1,400(rpm) 28° BTDC / 3,900(rpm)  12V 9AH CR8EH - 9 0.8 - 0.9mm 15A Kick/Starter Motor 12V 60W/55W 12V 10W × 4 12V 5W/21W 12V 3W/3.4W(1.7W × 2) 12V 1.7W 12V 1.7W

## Torque Values

### Engine

Item	Q'ty	Thread dia (mm)	Torque kgf.m,(N.m)	Remark
Oil Filter Screen Cap	1	36	1.5(15)	
Oil Filter Relief Valve Oval Screw	1	10	1.2(12)	
Oil Filter Cover Socket Bolt	3	6	1.1(11)	
Oil Pump Mounting Bolt	2	6	1.1(11)	
Valve Adjusting Screw Lock Nut	4	5	1.1(11)	
Drive Sprocket	2	6	1.2(12)	
Engine Hanger Bolt(Front)	2	8	2.7(27)	
Engine Hanger Bolt(Front 1, Rear 2)	3	10	4.9(49)	
Clutch Lock Nut	1	16	6.5(65)	Apply Engine Oil
Drum Stopper Arm Bolt	1	6	1.2(12)	
Primary Drive Gear Bolt	1	16	6.5(65)	Apply Engine Oil
R Crank Case Cover Bolt	11	6	1.1(11)	
Kick Starter Pedal Bolt	1	8	2.2(22)	
Gear Change Arm Bolt	1	6	1.2(12)	
Flywheel Bolt	1	10	5.5(55)	Apply Engine Oil
Starter Clutch Socket Bolt	3	8	3.2(32)	Apply a locking nut agent
Cam Chain Tensioner Pivot Bolt	1	8	1.1(11)	
Spark Plug	1	10	1.1(11)	
Cam Shift Holder 8mm nut	4	8	2.0(20)	Apply Engine Oil
Cam Chain Tensioner Mounting Bolt	2	6	1.2(12)	
Cam Chain Tensioner Sealing Screw	1	6	0.4(4)	
Cylinder Head Cover Bolt	2	6	1.0(10)	
Crank Shaft Hole Cap	1	30	0.8(8)	
Timing Hole Cap	1	14	0.6(6)	
L Crank Case Cover Bolt	7	6	1.1(11)	
Main Shaft Bearing Setting Plate	2	6	1.2(12)	Apply a locking nut agent
Crank Case Bolt	11	6	1.1(11)	
Starter Motor Terminal Nut	1	6	1.2(12)	
Cylinder(Oil Through Bolt)	2	12	3.2(32)	
Radiator(Oil Through Bolt)	2	12	3.2(32)	

### Frame

Item	Q'ty	Thread dia (mm)	Torque kgf.m,(N.m)	Remark
Handle Holder Bolt	2	10	2.6(26)	
Steering Stem Nut	1	22	7.4(74)	
Steering top Thread Nut	1	22	1.8(18) 0.3(3)	With a Starting torque With a Finishing torque
Front Fork Bottom Bridge Bolt	2	8	3.3(33)	
Front Fork Socket Bolt	2	8	2.0(20)	Apply a locking nut agent
Front Fork Tube Cap	2	26	2.3(23)	
Front Axle Nut	1	14	5.9(59)	
Ignition Switch Bolt	2	8	3.3(33)	
Front Brake Disk Nut	6	8	4.2(42)	Self lock nut

## General Information

Item	Q'ty	Thread dia (mm)	Torque kgf.m,(N,m)	Remark
Brake Caliper Bracket Bolt	2	8	3.0(30)	
Brake Caliper Bleed Valve	1	8	0.6(6)	
Brake Pad pin Bolt	2	8	(1.8, 13)	
Master Cylinder Reservoir Cap Screw	2	4	0.13(1.3)	
Brake Hose Bolt	2	10	3.4(34)	
Brake Lever Pivot Bolt	1	6	1.0(10, 7)	
Brake Lever Pivot Lock Nut	1	6	1.0(10, 7)	
Rear Axle Nut	1	14	8.8(88)	
Final Driven Sprocket Nut	4	10	5.9(59)	
Rear Brake Arm Bolt	1	6	1.0(10)	
Rear Shock Absorber Upper Bolt	1	10	3.4(34)	
Rear Shock Absorber Lower Bolt	1	10	3.4(34)	
Rear Fork Pivot Bolt	1	12	4.5(45)	Self lock nut
Rear Brake Pedal Bolt	1	8	2.2(22)	
Chain Tensioner Flange Nut	1	8	3.6(36)	

Torque specifications listed above are for important fastener. Other should be tighten to the standard torque values below.

Type	Torque		Type	Torque	
	kgf-m	N.m		kgf-m	N.m
5mm Bolt, nut	0.45~6	4.5~6	5mm Screw	0.35~0.5	3.5~5
6mm Bolt, nut	0.8~1.2	8~12	6mm Screw&Flange bolt (SH TYPE)	0.7~1.1	7~11
8mm Bolt, nut	1.8~2.5	18~25	6mm flange bolt, nut	1.0~1.4	10~14
10mm Bolt, nut	3.0~4.0	30~40	8mm flange bolt, nut	2.4~3.0	24~30
12mm Bolt, nut	5.0~6.0	50~60	10mm flange bolt, nut	3.5~4.5	35~45



## Safety Notices

Following marks indicate some warnings and caution against some specific service methods.

Mark	Meaning	Mark	Meaning
	Indicates a strong possibility of severe personal injury or loss of life if instructions are not followed		Indicates a possibility of personal injury or equipment damage if instructions are not followed.
			Gives helpful information

The following symbols indicate needed lubrication steps, the changing of parts, and required specialized tools, etc. when performing maintenance

Symbol	Caution	Symbol	Caution
	Use recommended engine oil, unless otherwise specified		Apply sealant
	Use molybdenum oil solution (mixture of the engine oil and molybdenum grease with the ratio 1:1)		Replace the parts with new ones before assembly
	Use multi-purpose grease (Lithium based multi-purpose grease NLGI #2 or equivalent)		Use brake fluid, DOT3 or DOT4. Use the recommended brake fluid, unless otherwise specified.
	Use molybdenum disulfide grease (containing more than 3% molybdenum disulfide, NLGI #2 or equivalent)		Use Forkor Suspension Fluid
	Use molybdenum disulfide paste containing more than 40% molybdenum disulfide, NLGI #2 or equivalent)		Use special tool
	Use silicone grease		Use optional tool. These tools are obtained as you order parts
	Apply a locking agent. Use the agent of the middle strength, unless otherwise specified		Indicates reference page. (Example: Refer to page 3-1)

Special greases, etc. that do not correspond to the above are indicated without using symbols.

## General Information

### Tools

Special		Common	
Description	Reference section	Description	Reference section
Clutch Center Holder	6	Wrench, 8 × 9mm	3
Flywheel Puller	7	Adjusting Wrench, B	3
Lock Pin Puller Set	8	Float Level Gauge	4
Sliding shaft	8	Lock Nut Wrench, 20 × 24mm	6
Sliding Weight	8	Extension Bar	6, 13
Valve Guide Reamer	8	Fly Wheel Holder	6, 7
Universal Bearing Puller	10	Valve Spring Compressor	8
Bearing Remover Set, 15mm	10	Driver	10, 13, 14
Remover Assy, 15mm	10	Attachment, 32 × 35mm	10, 14
Remover Shaft, 15mm	10	Attachment, 42 × 47mm	10, 13, 14
Remover Head	10	Attachment, 62 × 68mm	10
Sliding Weight	10	Attachment, 72 × 78mm	10
Thread Adopter	10	Pilot, 15mm	10, 14
Assembly Shaft	10	Pilot, 20mm	10
Crank Case Assembly Color	10	Pilot, 35mm	10
Ball Race Driver	13	Pilot, 28mm	10
Steering Stem Driver	13	Lock Nut Wrench, 30 × 32mm	13
Fork Seal Driver	13	Attachment, 37 × 40mm	13
Steering Stem Socket	13	Pilot, 12mm	13
Snap Ring Pliers	15	Fork Seal Driver Body	13
		Remover Head, 12mm	13
		Bearing Remover Shaft	13, 14
		Remover Head, 15mm	14
		Rear Cushion Compressor	14
		Attachment	14

## Tester, Gauge

Description	Reference section	Remark
Compression Gauge	3	
Digital Circuit Tester	16, 17	
Circuit Tester	16, 17	
Inspection Adapter	17	
Spark Adapter	17	

## Valve Seat Cut

Description	Reference section	Remark
Valve Seat Cutter 45°	8	24.5mm IN, EX
Valve Seat Cutter 35°	8	23mm IN
Valve Seat Cutter 35°	8	20mm EX
Valve Seat Cutter 60°	8	22mm IN, EX
Cutter Holder 5mm	8	Use with Valve Seat



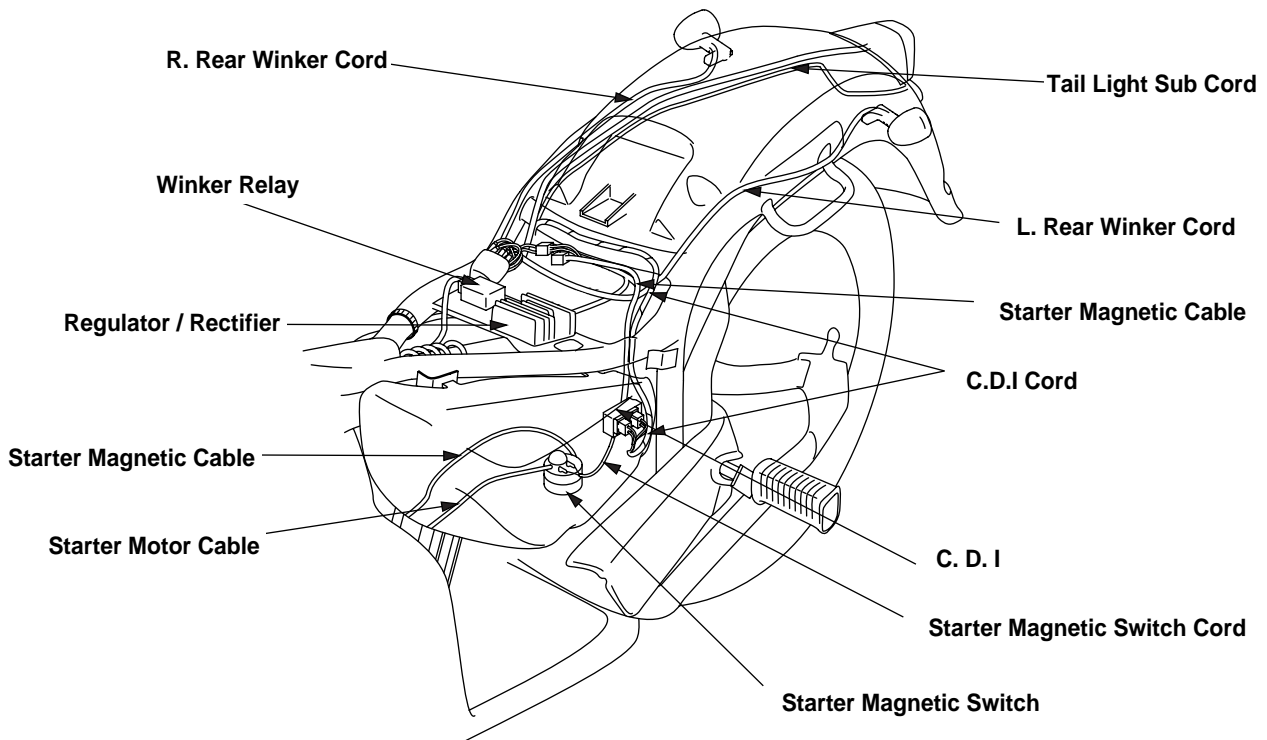
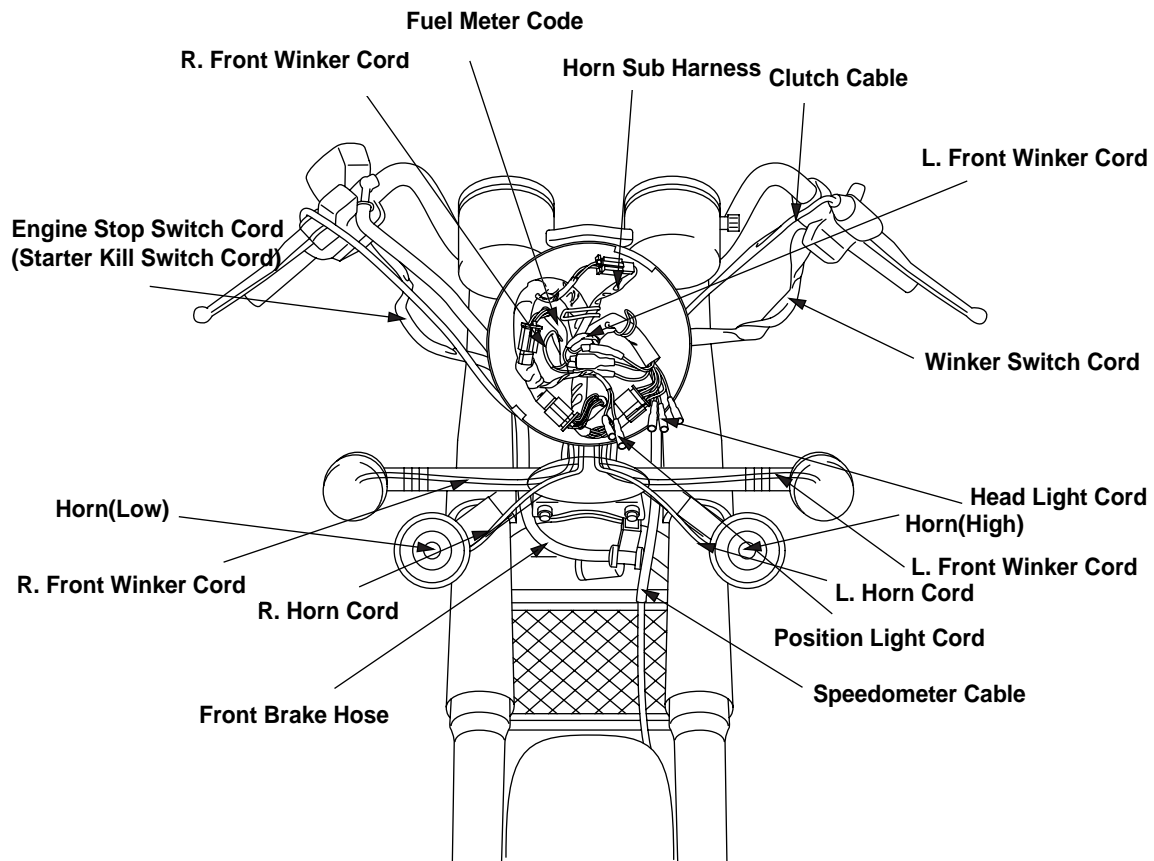

# General Information

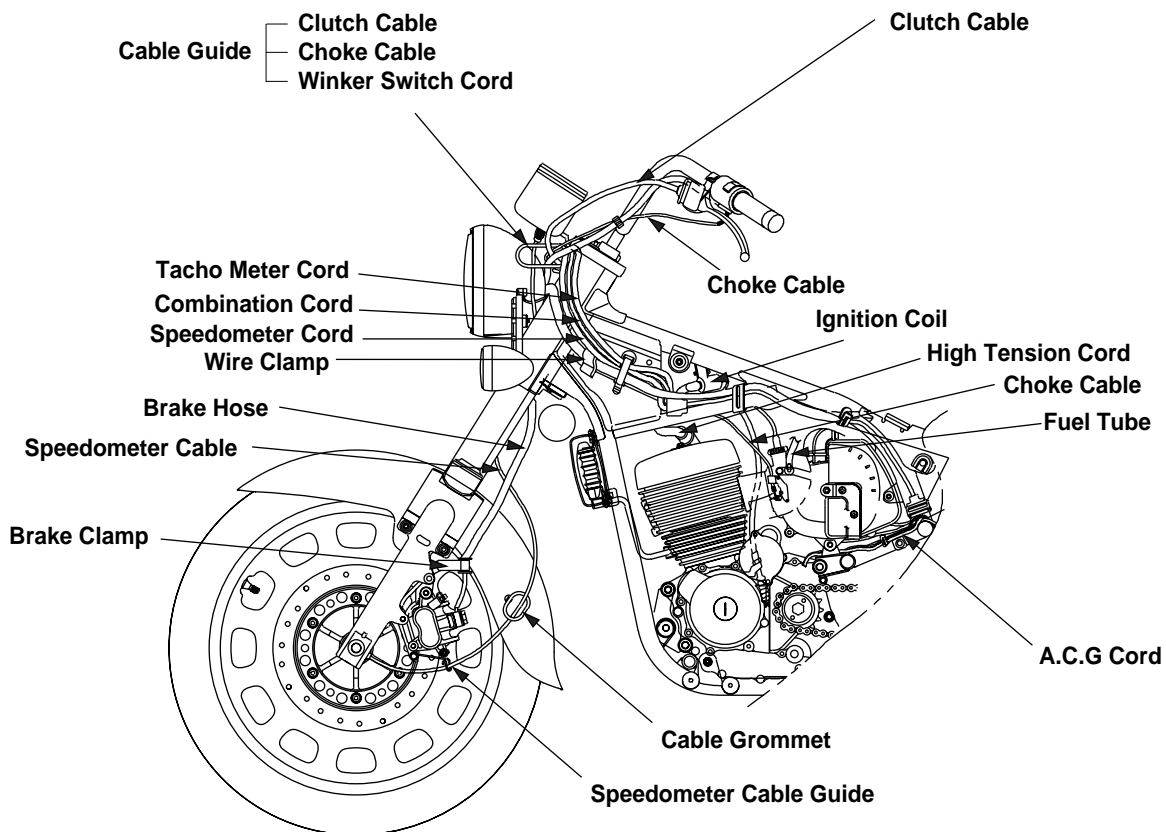
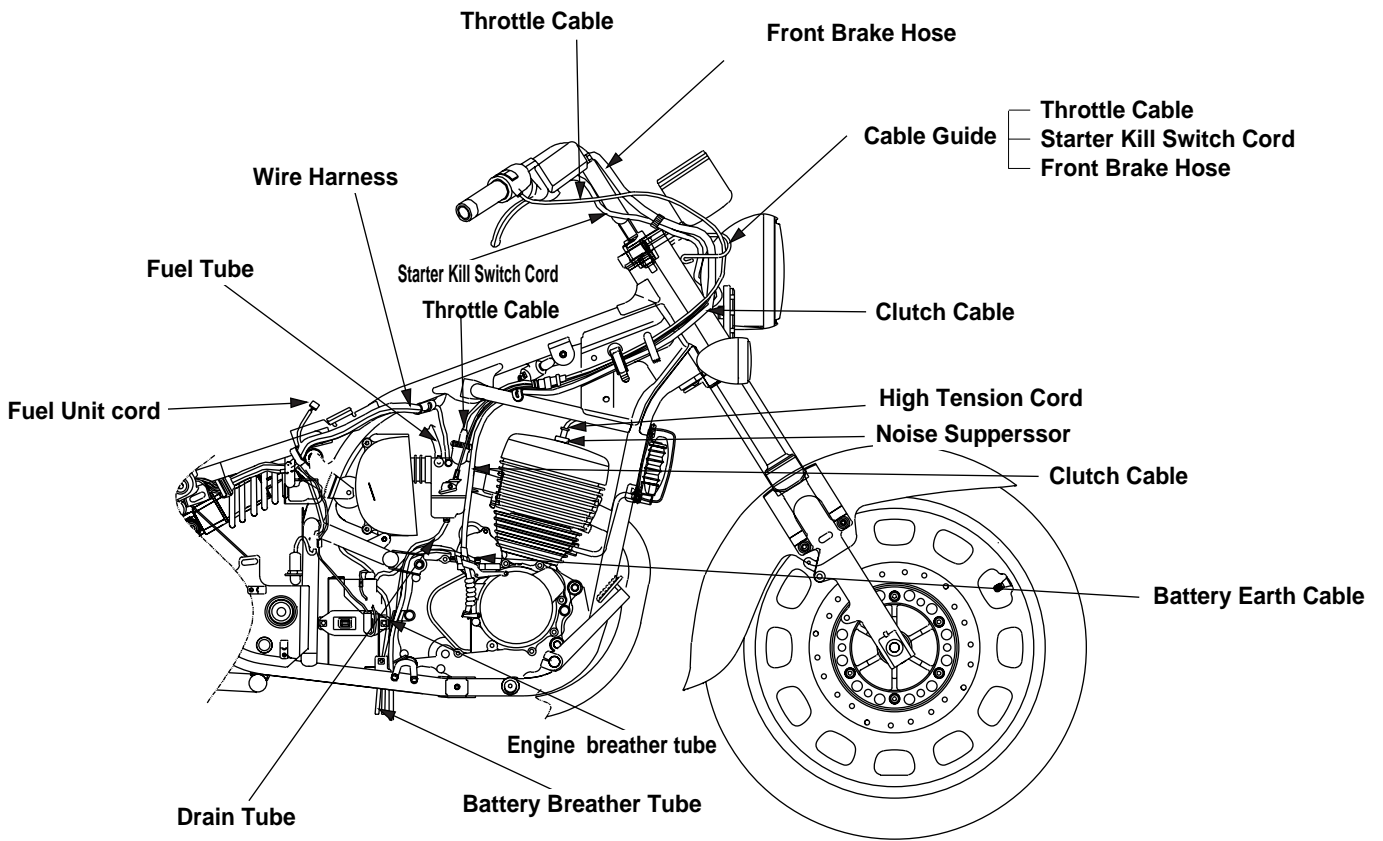

## 2. Lubrication

<b>Service Information</b> .....	<b>2-1</b>	<b>Engine Oil Change</b> .....	<b>2-3</b>
<b>Specifications</b> .....	<b>2-1</b>	<b>Engine Oil Filter Element Change</b> ..	<b>2-4</b>
<b>Troubleshooting</b> .....	<b>2-2</b>	<b>Oil Pump</b> .....	<b>2-4</b>
<b>Engine Oil Level Check</b> .....	<b>2-3</b>	<b>Lubrication Points</b> .....	<b>2-7</b>

2

### Service Information

**⚠ WARNING**

1. If the engine must be running to do some work, make sure the area is well ventilated. Never run the engine in an enclosed area. The exhaust contains poisonous carbon monoxide gas that may cause loss of consciousness and lead to death. Run the engine in an open area or with an exhausted evacuation system in an enclosed area.
2. Used engine oil may cause skin cancer if repeatedly left in contact with the skin for prolonged. Although it is unlikely to happen unless you handle used oil on a daily basis, it is still advisable to wash your hands thoroughly with soap and water as soon as possible after handling used oil.
3. The oil pump can be serviced with the engine installed in the frame.

### Specifications

#### Engine oil

Oil Capacity	1.2 l (all capacity) 1.15 l (after oil filter change) 1.1 l (after oil change)
Oil Recommendation	<p>API Service Classification:SE or SH Viscosity:SAE10W-30 (Other viscosities shown in the chart may be used when the average temperature in your riding area is within the indicated range.)</p>

#### Oil Pump

Unit : mm(in)

Item	Standard Value	Service Limit
Pump Body clearance	0.15~0.20(0.006~0.008)	0.25(0.010)
Rotor end clearance	0.15(0.006)	0.20(0.008)
Pump side clearance	0.05~0.09(0.002~0.004)	0.12(0.005)

#### Torque Valves

Oil Filter Screen Cap	1.5kgf-m(15N.m)
Oil Filter Relief Valve Oval Screw	1.2kgf-m( 9N.m)
Oil Filter Cover Socket Bolt	1.1kgf-m(11N.m)
Oil Pump Mounting Bolt	1.1kgf-m(11N.m)

# Troubleshooting

### Low oil pressure

- Oil level low
- Pressure relief valve stuck open
- Plugged oil pick-up screen
- Oil pump worn
- External oil leaks

### High oil pressure

- Pressure relief valve stuck closed
- Plugged oil filter, gallery, or metering orifice
- In correct oil being used

### No oil pressure

- Oil level low
- Oil pump drive gear broken
- Oil pump faulty
- Internal oil leakage



## Engine Oil Level Check

- Run the engine and allow it to idle for few minutes. Stop the engine and place the motorcycle on its center stand.
- After 2-3 minutes, check the oil level with the filler cap/dipstick.
- Do not screw it in when making this check.
- If the oil level is below or near the lower level mark on the dipstick, add the recommended oil up to the upper level line.



## Engine Oil Change

### ⚠ CAUTION

Change engine oil with engine warm and the motorcycle on its side stand to assure complete and rapid draining.

- Remove the oil filter cap.
- Remove the oil filter cap, spring, and screen.
- Start quick starter arm several times and drain the oil from the engine.
- Clean the filter screen with clean wash. check that the oil filter screen and O-ring of the screen cap are in good condition. Assemble filter screen, spring and cap.

Torque : 1.5kgf-m(15N.m)

Fill the crankcase with recommended engine oil.

Oil Capacity :

- 1.2 l (After disassembly)
- 1.15 l (After Oil filter change)
- 1.1 l (After oil change)

Oil Recommendation :

- DAELIM genuine oil
- API service classification : SE or SH
- Viscosity : SAE 10W-30

- Install the oil level gauge.
- Start the engine and let it idle for a few minutes.
- Stop the engine and check that the oil level is at the upper level mark. If the oil level is below or near the lower level mark, add the recommended oil up to the upper level mark,
- Make sure if there is no oil leak.

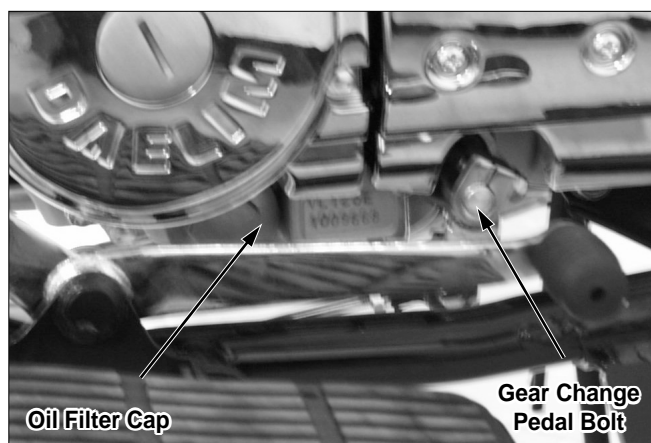

### Engine Oil Filter Element Change

- Remove the drain plug and drain the oil. (⇒2-3)
- Remove the oil filter cover bolt, filter cover, filter element and spring.
- Replace the oil filter element with a new oil filter.
- Check the operation of the relief valve.
- If the relief valve is fully opened when released, it is in good condition.
- Check if the oil filter seal is in good condition.
- Install the filter element spring and filter cover, and tighten the socket bolt.

Torque

Oil filter cover : 1.1kgf-m(11N.m)

Oval screw : 1.2kgf-m(12N.m)

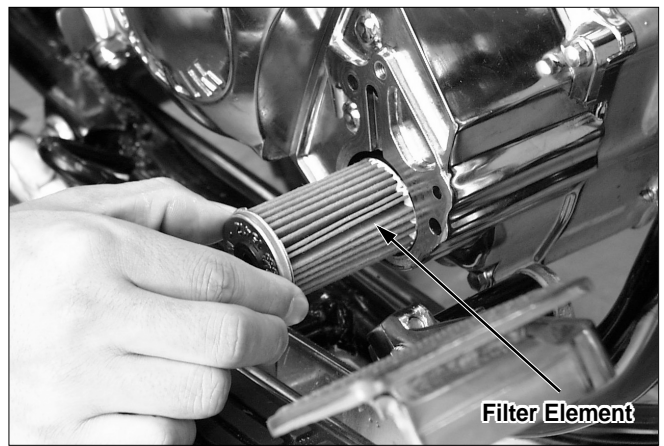

### Oil Pump

#### Removal

- Remove the right crank case cover. (⇒6-3)
- Remove the oil pump mounting bolts, oil pump, pump plate, and lock pin.
- Clean the oil pump body, inner and outer rotors with cleaning solvent.

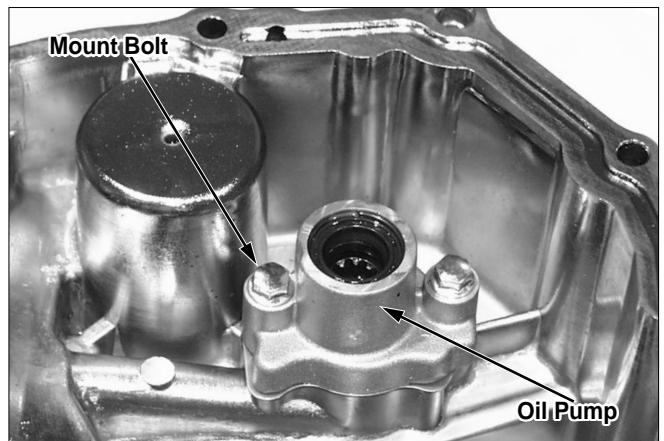

#### Inspection

- Install the inner and outer rotor into the oil pump body.
- Measure the pump body clearance.  
Service Limit : 0.25mm(0.010 in)

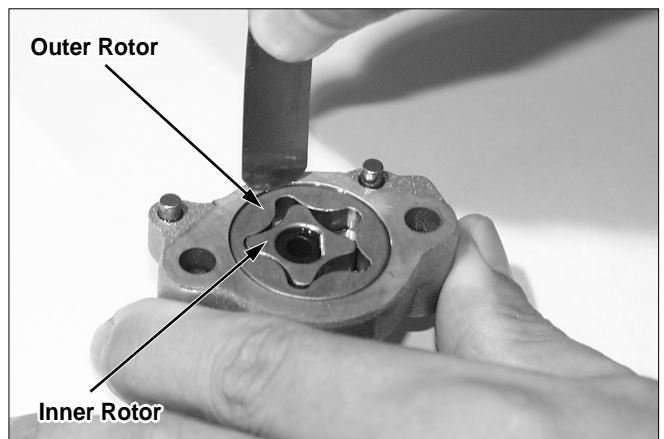

- Measure the rotor end clearance.  
Service Limit : 0.20mm(0.008 in)

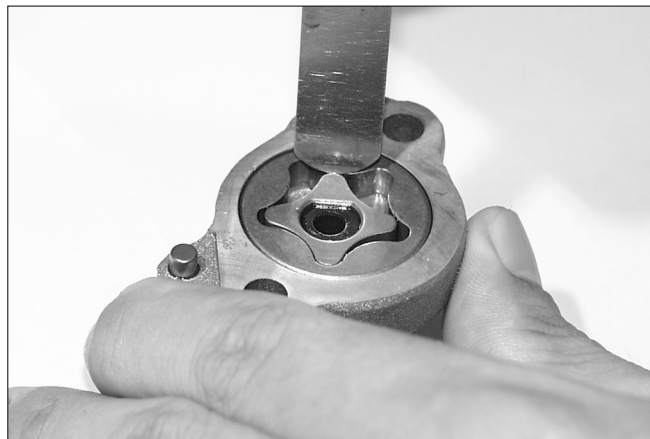

- Measure the pump side clearance.  
Service Limit : 0.12mm(0.005 in)



### Disassembly / Assembly

- Remove the inner and outer rotor from pump body.
- Remove the setting ring, spacer, oil seal and pump shaft. Clean each parts with cleaning solvent.

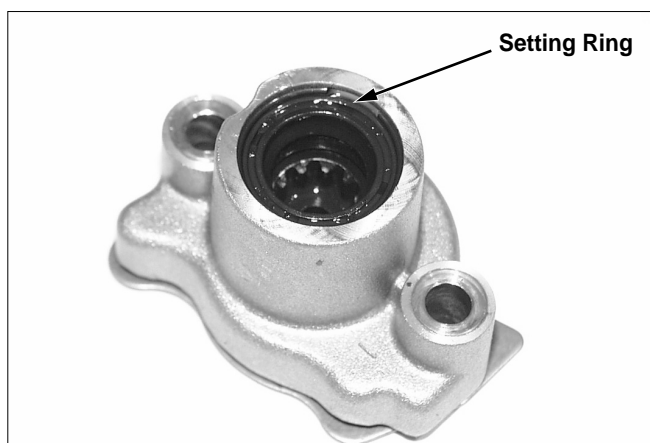

- Connect the pump shaft, oil seal, and spacer, then install into the setting ring.
- Install the inner and outer rotors.

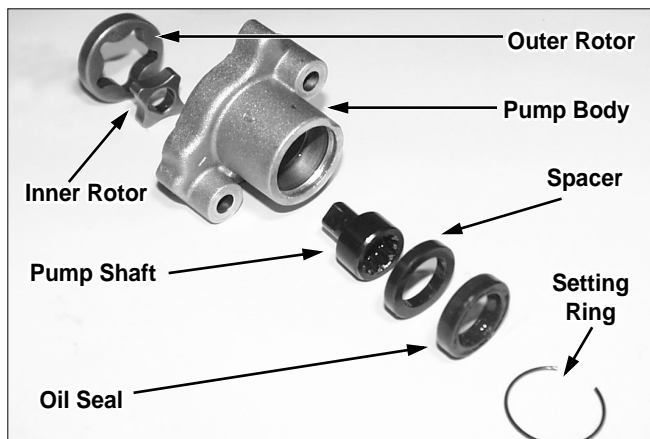

## Lubrication

---

- Remove the oval screw, sealing washer, spring and relief valve from oil filter cover.
- Remove the oil filter element from R. crank case cover.
- Blow the oil path way of crank case cover with compressed air, and clean.

Torque

Oil filter cover : 1.1kgf-m(11N.m)

Oval screw: 1.2kgf-m(12N.m)

- Install the dowel pins and oil pump plate into the pump body.

- Install the oil pump into the right crank case cover and tighten the bolt.

Torque : 1.1kgf-m(11N.m, 8ft-lb)

- Install the right crank case cover

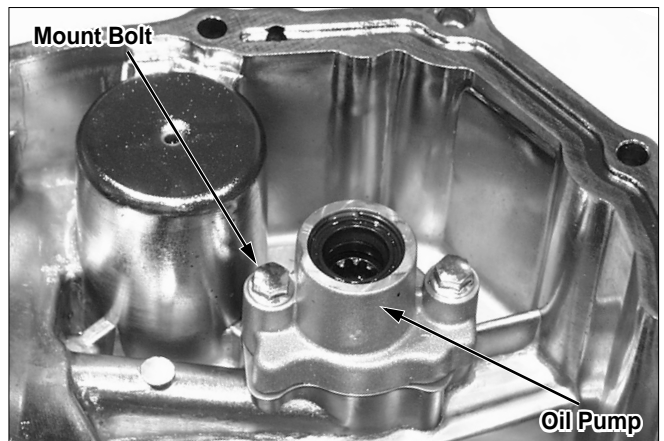
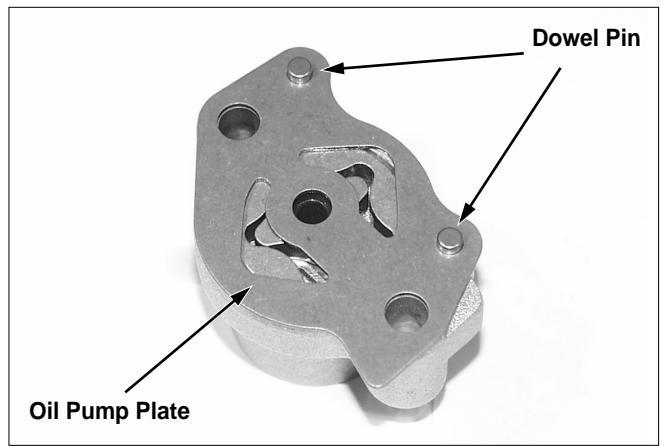
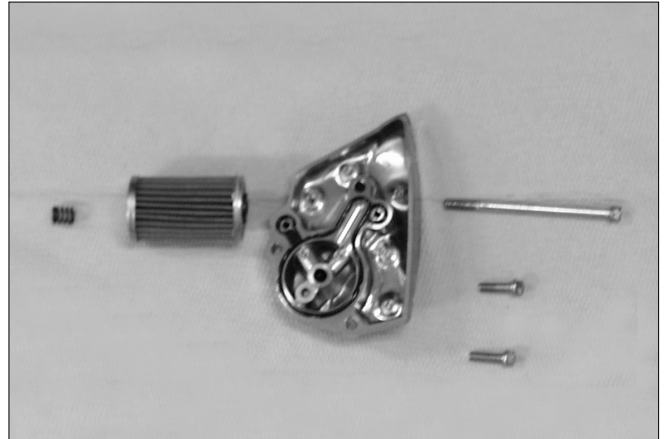

## Lubrication points

if there is no specific indication of oil, use general grease to lubricate the lubrication parts. Lubricate the other operation parts which are not shown below with oil or grease.

### Control Cable Lubrication

Periodically, disconnect the throttle cables at their upper ends. Thoroughly lubricate the cables and their pivot points with a commercially available cable lubricant or a light weight oil. Check the cable for loose, replace them if necessary.

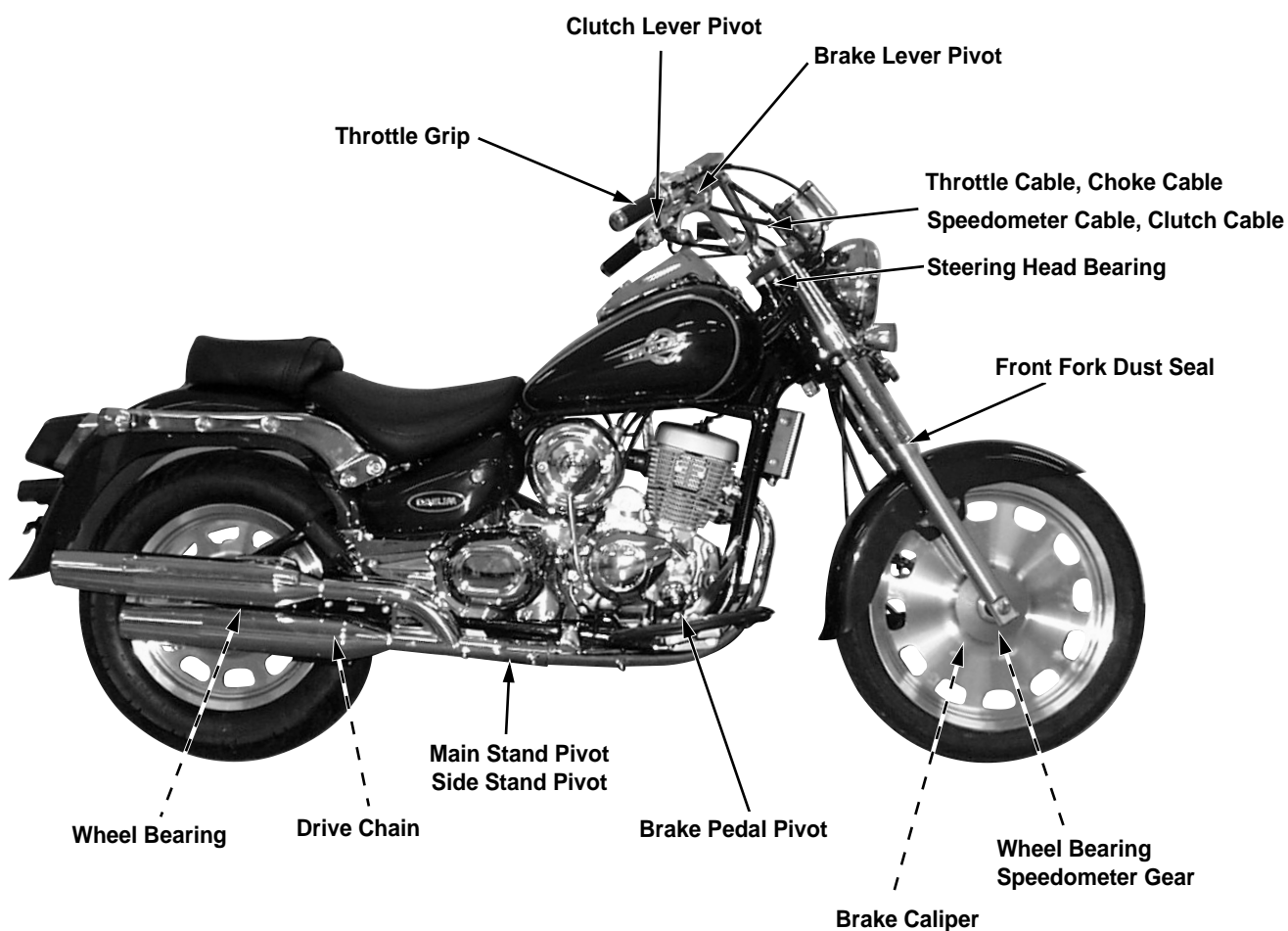



## 3. Maintenance

Service Information .....	3-1	Brake Fluid .....	3-10
Maintenance Schedule .....	3-3	Brake Pad / Shoe .....	3-10
Fuel Line .....	3-4	Brake System .....	3-11
Throttle Grip Operation .....	3-4	Brake Stop Switch .....	3-12
Carburetor Choke .....	3-5	Headlight Adjustment .....	3-12
Air Cleaner .....	3-5	Clutch .....	3-12
Spark Plug .....	3-6	Side Stand .....	3-13
Valve Clearance .....	3-6	Suspension .....	3-13
Cylinder Compression Pressure ...	3-7	Bolts, Nuts Fasteners .....	3-14
Carburetor Idle Speed .....	3-8	Wheels / Tires .....	3-14
Drive Chain .....	3-8	Steering Head Bearings .....	3-15
Battery .....	3-10		

## Service Information

### \* NOTE

- If the engine must be running to do some work, make sure the area is well ventilated. Never run the engine in an enclosed area. The exhaust contains poisonous carbon monoxide gas that may cause loss of consciousness and lead to death. Run the engine in an open area or with an exhausted evacuation system in an enclosed area.
- Engine oil and oil filter see page 2-3, 2-4
- Before working, stand the main stand.

### Specifications

- Throttle grip free play: 2 – 6mm(0.078~0.236 in)
- Spark plug: CR8EH – 9
- Spark plug gap: 0.8 – 0.9mm(0.031-0.035in)
- Valve clearance: IN)  $0.12 \pm 0.02\text{mm}(0.005-0.001\text{in})$   
EX)  $0.12 \pm 0.02\text{mm}(0.005-0.001\text{in})$
- Carburetor idle speed:  $1,400 \pm 100(\text{rpm})$
- Cylinder compression:  $14 \text{ kgf/cm}^2(550\text{rpm})$
- Drive chain free play: 50~60mm(1.968~2.362 in)
- Rear brake pedal free play: 20~30mm(0.787~1.181 in)
- Clutch lever free play: 10~20mm(0.393~0.787 in)

### Tires

Cold tire pressure	Driver only	Front	200kPa (2.00kgf/cm <sup>2</sup> )
		Rear	200kPa (2.00kgf/cm <sup>2</sup> )
	Driver and a passenger	Front	200kPa (2.00kgf/cm <sup>2</sup> )
		Rear	200kPa (2.00kgf/cm <sup>2</sup> )
Tire size	Front	90/90 -18	
	Rear	130/90 -15	
Tire $\square$ part minimum-depth	Front	4mm (0.16 in)	
	Rear	8.5mm (0.3 in)	

## Maintenance

---

### Torque Values

Spark Plug	1.1 kgf-m( 11N.m)
Cylinder Head Cover Bolt	1.0 kgf-m( 10N.m)
Valve Adjusting Nut	1.1 kgf-m( 11N.m)
Timing Hole Cap	0.6 kgf-m( 6N.m)
Crankshaft Hole Cap	0.8 kgf-m( 8N.m)
Rear Axle Nut	8.8kgf-m(88N.m)

### Tools

Common Tool

Wrench, 8 ×9 mm

Adjuster Wrench

Compression Gauge



## Maintenance Schedule

Perform the Pre-ride inspection in the Owner's manual at each scheduled maintenance period.

I : Inspect and clean, adjust, lubricate or replace if necessary

R : Replace      L : Lubricate      C : Clean

Item		Frequency	Odometer Reading (NOTE 1)				Refer to Page	Remark
			1,000km	4,000km	8,000km	12,000km		
*	Fuel Line	I	I	I	I	3-4		
*	Fuel Filter		R	R	R	3-4		
*	Throttle Grip Operation		I	I	I	3-4		
*	Carburetor Choke		I	I	I	3-5		
	Air Cleaner		R	R	R	3-5	NOTE 2	
	Spark Plug		I	R	I	3-6		
*	Valve Clearance	I	I	I	I	3-6		
**	Engine Oil	R	R	R	R	2-3		
	Engine Oil filter Element	R	R	R	R	2-4		
*	Carburetor Idles speed	I	I	I	I	3-8		
	Drive Chain	1,000km : I,L					3-8	
	Battery Fluid		I	I	I	3-10		
	Brake Fluid		I	I	I	3-10	NOTE 3	
	Brake Shoe/Pad		I	I	I	3-10		
	Brake System	I	I	I	I	3-11		
*	Brake Stop Switch		I	I	I	3-12		
*	Head Light Aim		I	I	I	3-12		
	Clutch System	I	I	I	I	3-12		
	Side Stand		I	I	I	3-13		
*	Suspension		I	I	I	3-13		
*	Bolt, Nut Fastener	I		I		3-14		
**	Wheels/Tires		I	I	I	3-14		
**	Steering Head Bearing	I		I		3-15		

\* Should serviced by an authorized DAELIM dealer, unless the owner has proper tools and service date and is mechanically qualified.

\*\* In the interest of safety, we recommended these items be serviced only by an authorized DAELIM dealer.

### NOTES:

1. After high odometer reading 12,000km(7,500mi), repeat at the frequency interval established here.
2. Service more frequently when riding in unusual wet or dusty areas
3. Replace every 2 years. In case of replacing, proper skills are needed.

### Fuel Line

- Check the fuel lines for deterioration, damage, or leakage. Replace the fuel lines.

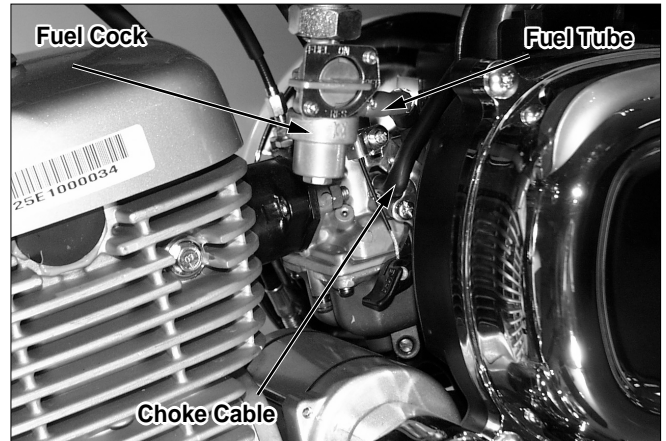

### Throttle Grip Operation

- Check the throttle grip for smooth operation.
- Complete opening and automatic closing in all steering positions.
- Lubricate the throttle cables if throttle operation is not smooth (⇒2-7)
- Make sure if there is no deterioration, damage, or kinking in the throttle cables.
- Measure the throttle grip free play at the throttle grip flange.

Free Play : 2~6mm(0.078~0.236in)



- Adjust the free play by loosening the lock nut and turning the adjuster. Tighten the lock nut.
- Recheck the throttle free play.

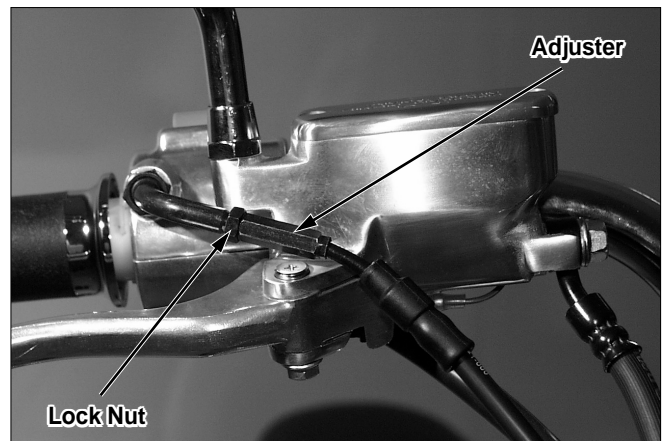

## Carburetor Choke

- Make sure if there is no deterioration, damage or kinking in the choke cable. Check for smooth chock lever operation at any adjusting position.
- Pull the choke lever forward all the way up to fully closed. Make sure that the choke valve is fully closed by moving the choke arm. If necessary, adjust the choke valve up to the fully opened position by loosening the choke cable clamp and moving the choke cable cover.
- Depress the choke lever forward up to the fully opened position. Make sure that the choke valve is fully opened by checking the operation between the choke arm and cable cover.
- Recheck the carburetor choke free play.

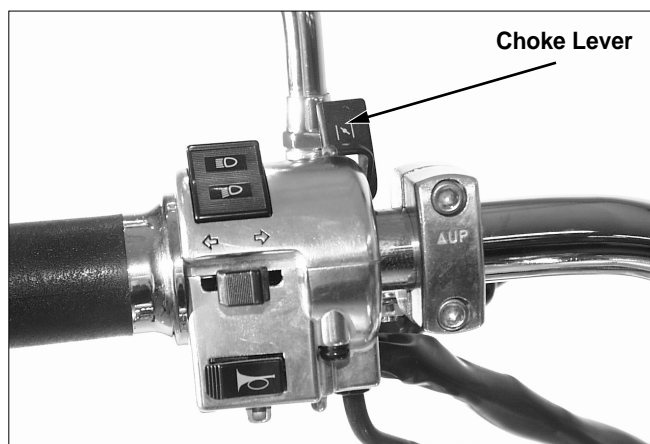

## Air Cleaner

- Loosen the four screw, and remove the air cleaner case cover.
- Loosen the three screw, and remove the air cleaner element.

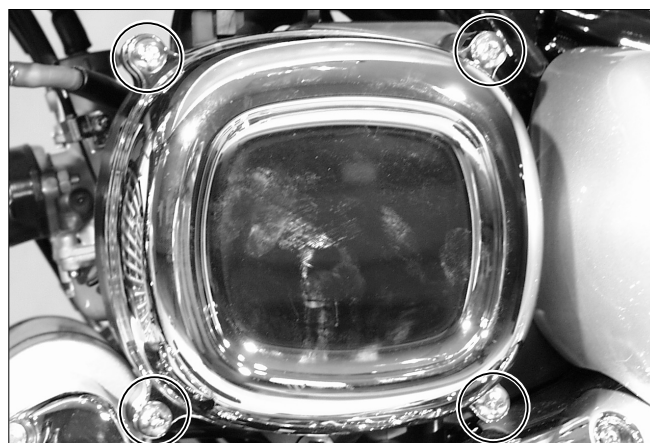

## Maintenance

- Make sure if there is no deterioration and damage in the air cleaner element. Replace damaged parts.

### \* NOTE

- The element is a viscous type which contains oil. Therefore do not use compressed air to clean the air cleaner element.
- Assemble the Air cleaner element in the reverse order of removal

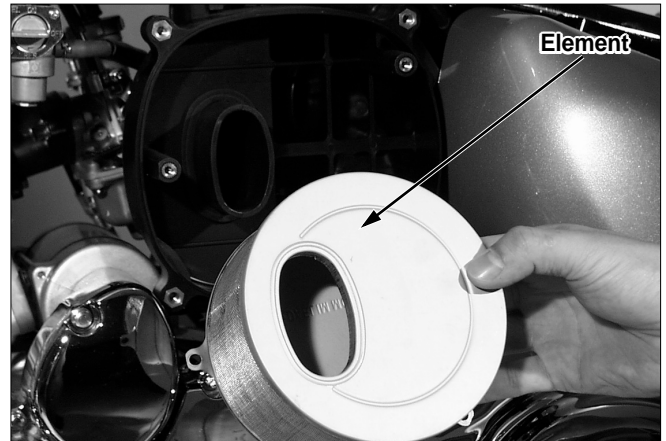

## Spark Plug

- Remove the spark plug cap and spark plug.
- Check any dirt, damage from around the spark plug bases. If necessary, clean away the dirt from around the spark plugs with a plug cleaner or a wire brush.
- Measure the new spark plug using a wire-type feeler gauge. Adjust the gap by bending the side electrode carefully.  
Pure Plug : CR8EH-9  
Spark Plug Gap : 0.8~0.9mm

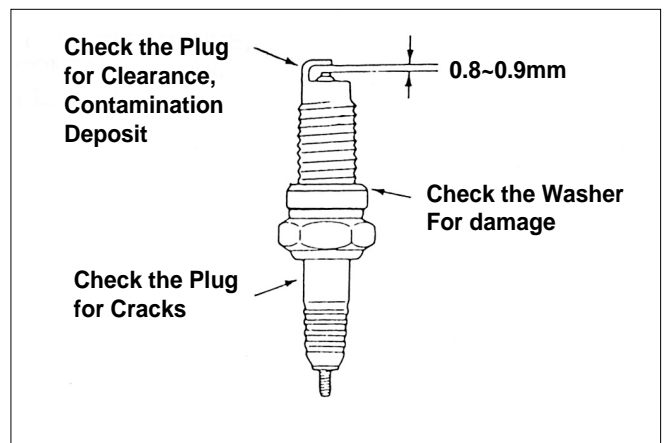

### \* NOTE

- Install the plug by turning with finger. Tighten it with plug wrench.  
Torque: 1.1kgf.m(11N.m)  
Install the spark plug caps

## Valve Clearance

### \* NOTE

- Perform valve inspection/adjustment with the engine at normal operating temperature (Below 35°C / 95°F)  
Remove the cylinder head cover. Align the "T" mark on the flywheel with the index mark on the left crank case cover, turning the flywheel to the left.  
At this time, the piston should be placed on the groove of the compression stroke.



- Measure the valve clearance with filler gauge.  
Valve Clearance:  
Intake:  $0.12 \pm 0.02\text{mm}$  ( $0.05 \pm 0.001\text{in}$ )  
Exhaust:  $0.12 \pm 0.02\text{mm}$  ( $0.05 \pm 0.001\text{in}$ )
- Loosen the lock nut with a valve wrench, and adjust the adjuster screw to the standard clearance using a valve adjusting wrench. When the standard clearance is done, hold the adjuster screw with a valve adjusting wrench. And then tighten the lock nut.  
Torque : 1.1kgf-m(11N.m)  
Tools : Wrench 8×9mm  
Adjusting wrench
- Measure the valve clearance again.
- After connecting the cylinder head cover, tighten the bolt.  
Torque : 1.0kgf-m(10N.m)
- Install the timing hole cap and crank case hole cap.  
Timing Hole Cap : 0.6kgf-m(6N.m)  
Crank Case Hole Cap : 0.8kgf-m(8N.m)

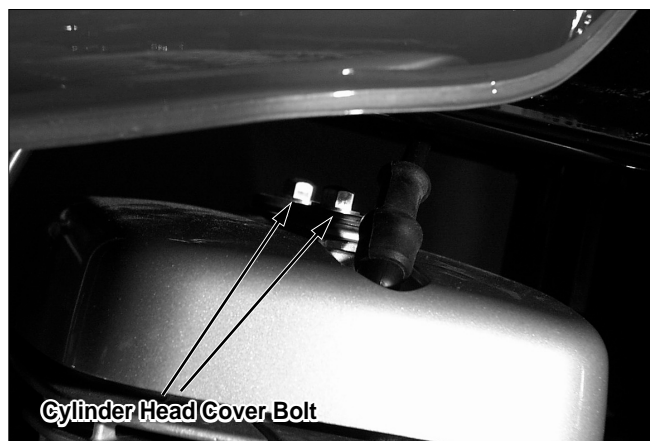
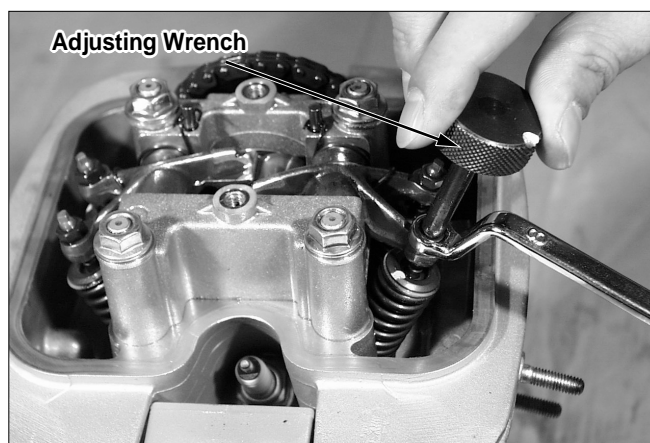
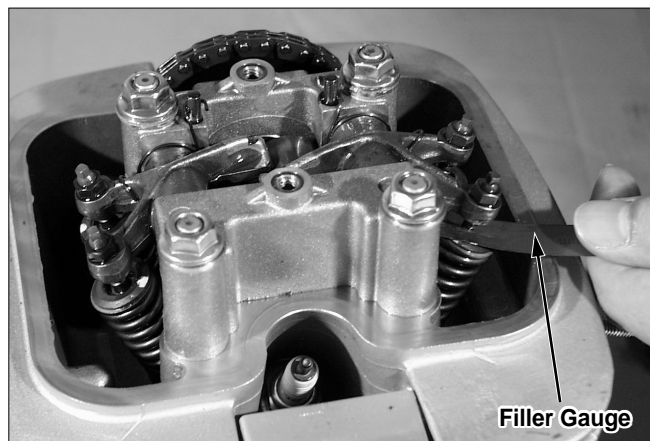

## Cylinder Compression Pressure

- Warm up the engine to normal operating temperature.
- Stop the engine, disconnect the spark plug caps and spark plug. Install the compression gauge.
- Open the throttle all the way and crank the engine with the starter motor until the gauge reading stops rising.  
Tool: Compression gauge

### \*NOTE

- The maximum reading is usually reached within 4~7 seconds.  
Compression Pressure : 14.0 kgf/cm<sup>2</sup>(550rpm)
- If compression is low, check the following:
- Incorrect valve clearance adjustment
  - Valve for leakage
  - Exposed cylinder head from the gasket
  - Worn piston/cylinder
- If compression is high, check the following:
- Carbon deposits on the piston head, cylinder head

## Carburetor Idle Speed

**\* NOTE**

- Inspect all other engine adjustments are within specifications and adjust idle speed.
- The engine must be warm for accurate adjustment. Support the motorcycle on a level surface and shift the transmission into neutral. Check the idle speed and adjust by turning the throttle stop screw if necessary.

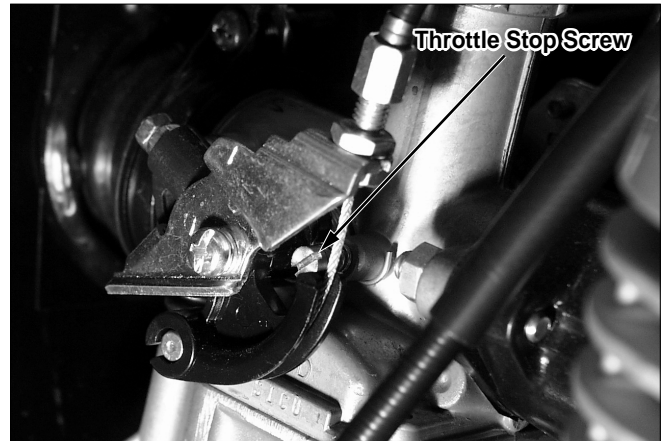

## Drive Chain

**\* NOTE**

- Stop the engine to inspect the drive chain, otherwise fingers can be caught in the drive chain while the drive chain is operating.

### Chain Free Play Adjustment

- Stop the engine and shift the gear into neutral, support the motorcycle on a level surface.
- Remove the chain tensioner.
- Move the position of chain tensioner roller up and down with hands to check if the chain free play is within recommended range.  
Free Play: 50~60mm
- If necessary, adjust the drive chain free play.
- Adjust by loosening the axle nut and lock nuts in the right/left chain adjusters and turning the adjusting nut.

**\* NOTE**

- Adjust the chain adjuster reading scale into the same place in the right and left sides.  
Tighten the axle nut  
Torque: 88kgf-m(88N.m)

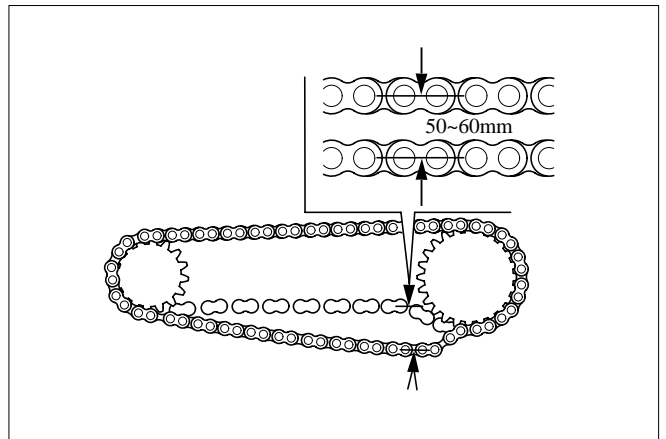
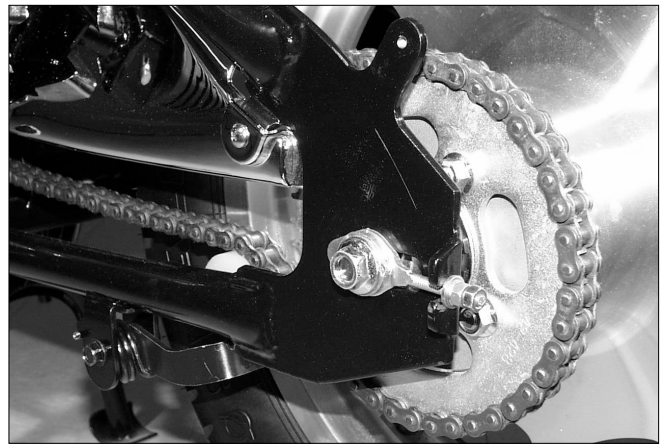

### Removal/Inspection

- Inspect the drive chain for contamination.

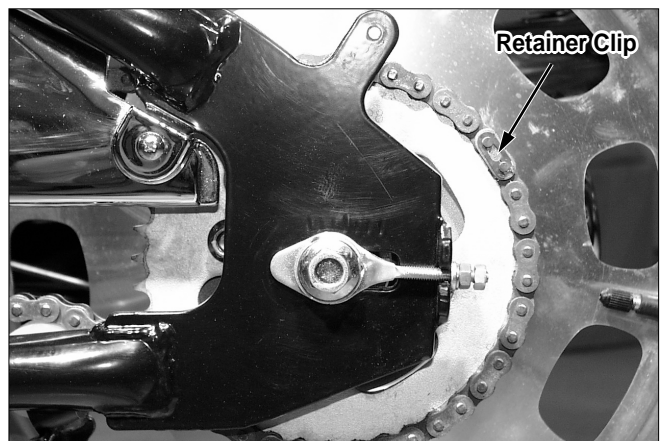

- Inspect the drive chain for adherence and damaging.
- Remove the contamination with a cleaner. After drying completely, coat the chain with #80-90 gear oil. Wipe any excessive oil off the chain, check the drive chain for wear and damage, replace it if necessary.
- Check the drive sprocket for wear and damage.
- Replace it if necessary.

**\*NOTE**

- New motorcycle adapts endless-type drive chain (end-type for after-sales service purpose)
  - After once disassembling chain, chain clip can be accidentally removed, so even change new one after disassembling chain once.
  - If the chain or sprocket requires replacement, the chain and sprocket must be replaced as a set.
- 
- Inspect the rollar for wear and damage, and remove the chain tensioner  
Service limit: 30.5mm

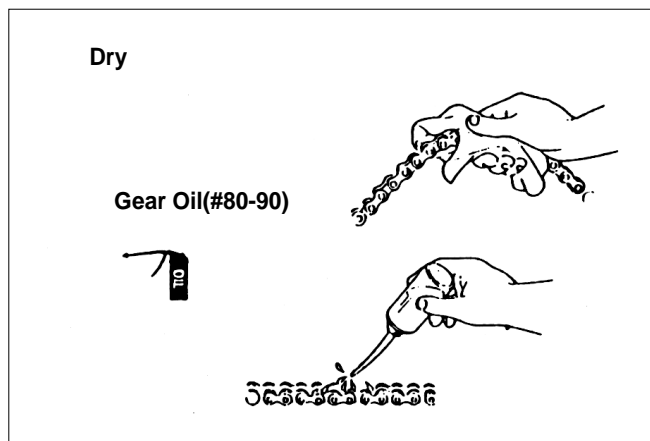

**Installation**

- After assembling the chain tensioner, keep the upper part of bracket which is holding chain tensioner-roller to the underline of rear swing arm under pipe.

**\*NOTE**

- Install the drive chain with the closed area of the clip facing to the proceeding direction. While driving, master link will be removed suddenly when facing to the opposite direction. Check for the master link-to-retainer clip clearance.

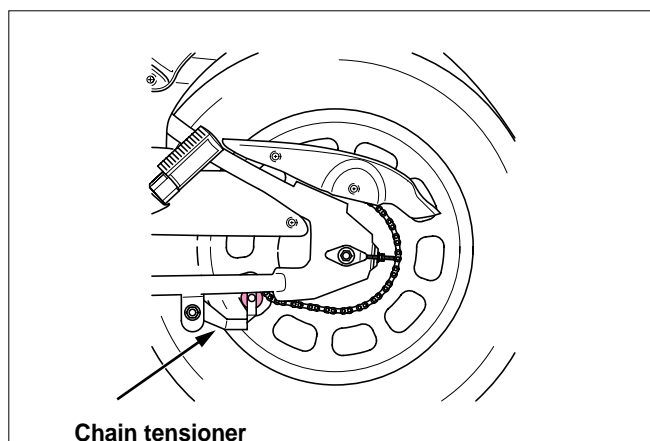
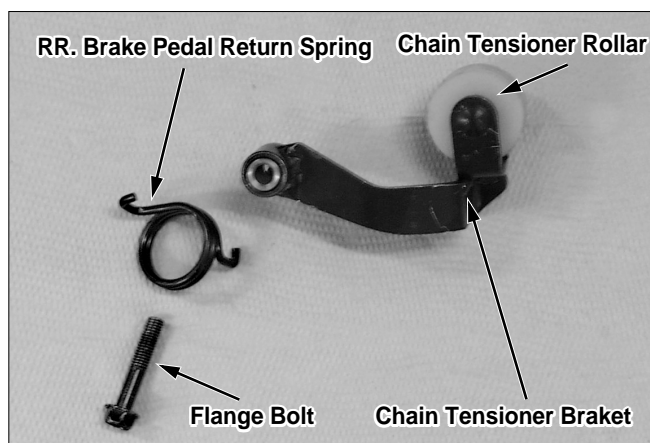

### Battery

- Remove the right side cover.
- Inspect the battery electrolyte level. When the level nears the lower level, add distilled water to the upper level.

#### \* NOTE

- Add only distilled water.
- Avoid spilling the fluid of battery on other parts.

#### ⚠ CAUTION

- The battery contains sulfuric acid(electrolyte). Contact with skin or eyes may cause severe burns. If electrolyte gets on your eyes, flush with water for at least 15 minutes and call a physician.
- Replace the battery when there is white electro deposits inside battery or residuals in the bottom of the cell from the electrodetype.

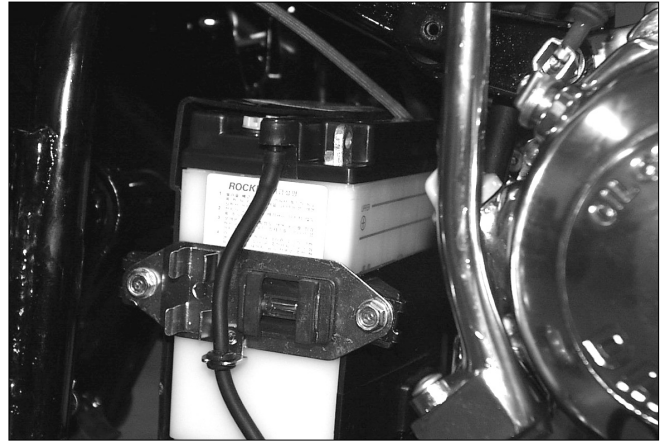

### Brake Fluid

- Check the fluid level of the front brake reservoir. If the level nears the lower level, remove the cover set plate and diaphragm. Fill the reservoir to the upper level with DOT 3 or DOT 4 fluid from a sealed container. Check the system for leaks.

#### ⚠ CAUTION

- Do not allow dust or water to enter the system when filling the reservoir.
- Do not remove the reservoir cover until the reservoir is level.
- Avoid spilling the fluid on painted, plastic, or rubber parts.

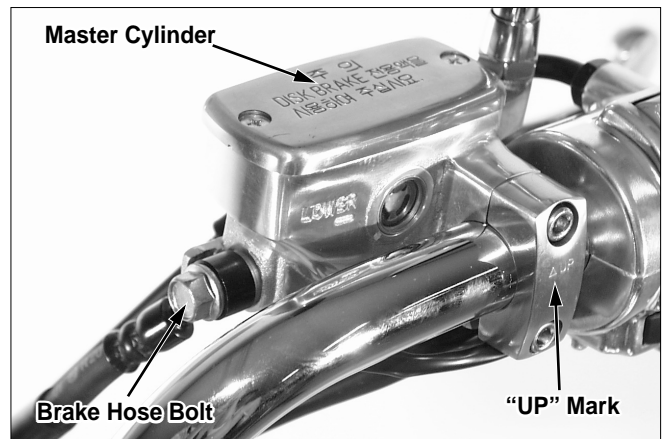

### Brake Pad/Shoe

#### Brake Pad Replacement

- Check the brake pads for wear. Replace the brake. If the red marks in the pads reach to the brake.(⇒15-4)

#### ⚠ CAUTION

- Always replace the brake pads as a set to assure even disc pressure.

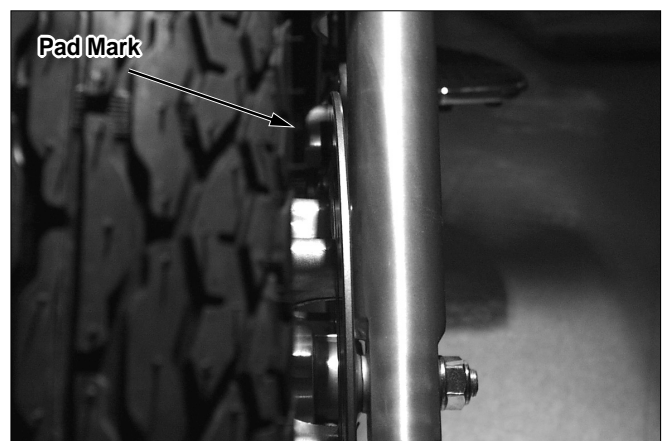



## Brake Shoe Replacement

- Replace the brake shoes if the arrow on the brake arm aligns with the reference mark “△” on full application of the rear brake pedal.

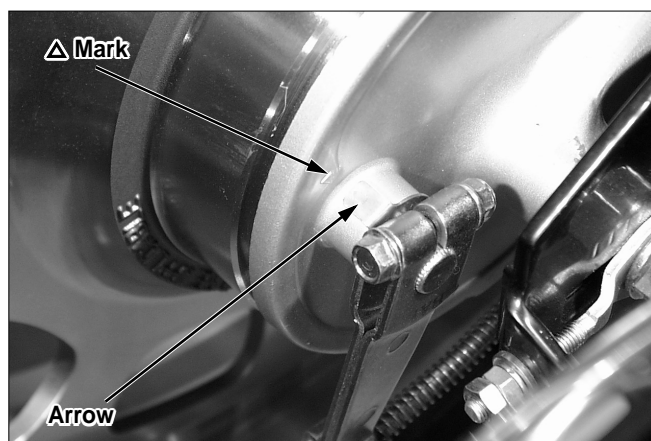

## Brake System

- Inspect the front brake hoses for deterioration, cracks. If there are signs of leakage, replace them as soon as possible. Replace hoses as required.
- Inspect the rear brake pedal and brake rod for looseness or damage. Tighten any loose fittings. Replace them if necessary.

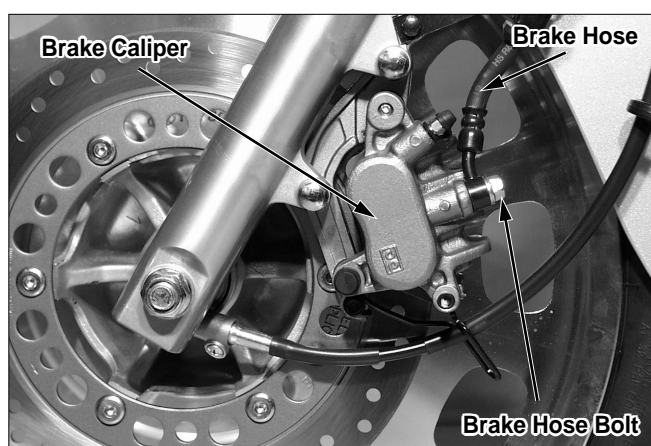

## Brake Pedal Height

- Perform brake pedal clearance adjustment after adjusting brake pedal height.  
Free play: 20~30mm(0.787~1.181in)



- If adjustment is necessary, use the rear brake adjusting nut.
- after adjusting the brake pedal free play, check the rear brake light switch operation and adjust it if necessary.

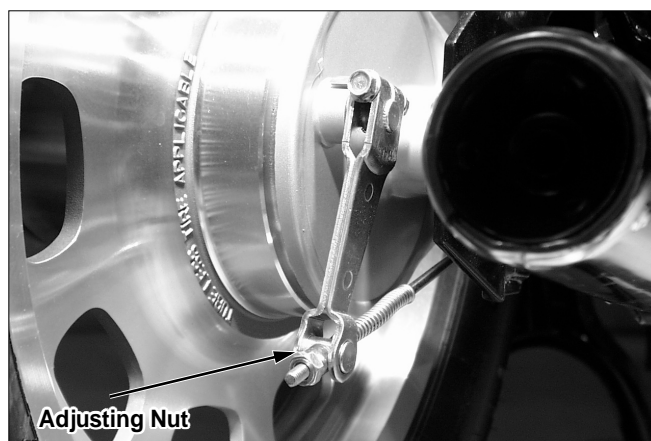

## Maintenance

### Height Adjustment

- Adjust the brake pedal height to 10-20mm.

#### ⚠ CAUTION

- The adjustment faulty of height may caused that the brake runs in state of operation. Loosen the lock nut, and then adjust the height by turning the brake pedal stoper bolt. After adjusting, tighten the lock nut securely.

- After adjusting the brake pedal height, inspect the operation of rear brake light switch and brake pedal, and adjust them if necessary.

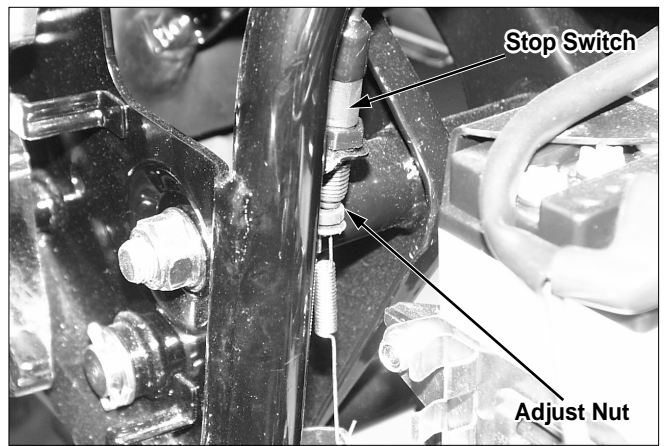

### Brake Stop Switch

- Adjust the brake light switch so that the brake light may come on, when the brake pedal is depressed, and brake engagement begin. Hold the switch body and turn the adjusting nut.

### Headlight Adjustment

- Adjust the headlight beam by turning the case adjustment screw.

#### \* NOTE

- Adjust the headlight beam as specified by local laws and regulations.

#### ⚠ CAUTION

- An improperly adjusted headlight may blind on coming drivers, or it may fail to light a road for a safe distance.



### Clutch

- Measure the clutch system free play at the end of clutch lever.  
Free Play: 10~20mm(0.393~0787 in)

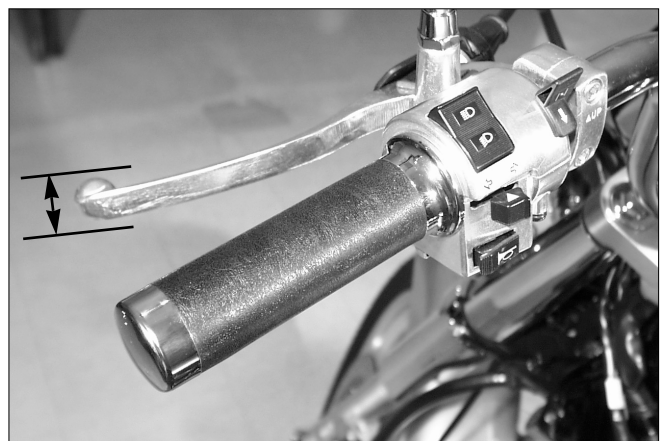

- Perform the light adjustment by loosening the lock nut from the handle and turning the adjuster.

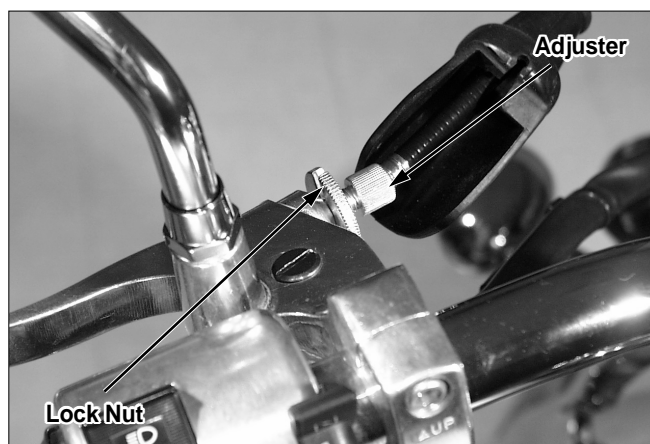

- Perform the main adjustment by loosening the lock nut from the engine and turning the adjusting nut.
- Tighten the lock nut.
- Inspect the clutch operation.

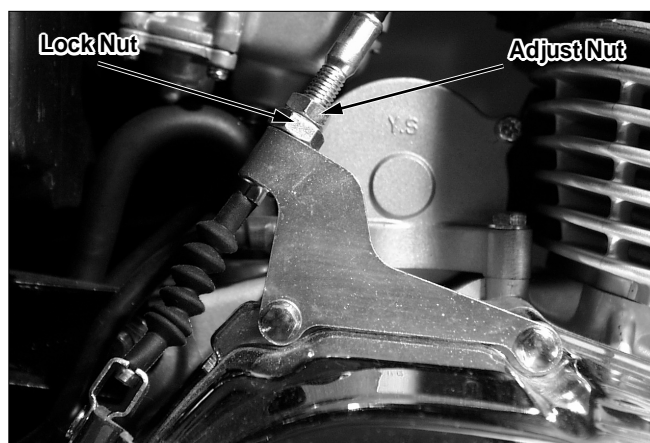

## Side Stand

- Set up the main stand.
- Check of smooth operation, when pulling the low end part of the side stand.
- If the side stand is hard, coat the pivot with grease.
- If the side stand moves too freely, inspect the side stand spring. Make sure that the side stand is not bent.



## Suspension

### ⚠ CAUTION

- Do not ride a vehicle with a faulty suspension. Loose, worn or damaged suspension parts impair vehicle stability and control.

### Front

- Check the action of the fork by compressing the front suspension several times.
- Check the entire fork assembly for leaks, damage, or looseness.



## Maintenance

### Rear

- Check the action of the rear cushion by compressing them several times. Check the rear cushion for leaks, damage, or looseness.
- Support the motorcycle with a main stand.
- Check for worn rear fork bush by attempting to move the wheel side to side. Replace the bearings if any looseness is noted. Tighten all nuts and bolts of the rear suspension.



### Bolts, Nuts Fasteners

- Check that all nuts and bolts are tightened to correct torque values.
- Check that all cotter pins, safety clips, hose clamps and cable stays are in place. (⇒3-3)

### Wheels/Tires

#### \* NOTE

- Tire pressure should be checked when the tires are cold.
- Check the tires for cuts, embedded nails, or other damage. Replace them if necessary.

Recommended Tire Pressure:      kgf/cm<sup>2</sup>(kPa)

	Front	Rear
1 Person	2.00(200)	2.00(200)
2 Person	2.00(200)	2.00(200)



- Measure the tread depth at the center of the tire.
- Replace the tire when the tread depth reaches the following limits:  
Minimum Tread Depth: 4mm (0.16 in)  
8.5mm (0.3 in)

## Steering Head Bearings

**\* NOTE**

- Check that the control cables do not interfere with handle bar rotation.
- Raise the front wheel off the ground. Check that the handle bar moves freely from side to side. If the handle bar moves unevenly, bends, or has vertical movement, inspect the cables and electric code wires. If the handle bar moves too freely, adjust the steering head bearings.



# Fuel System

---

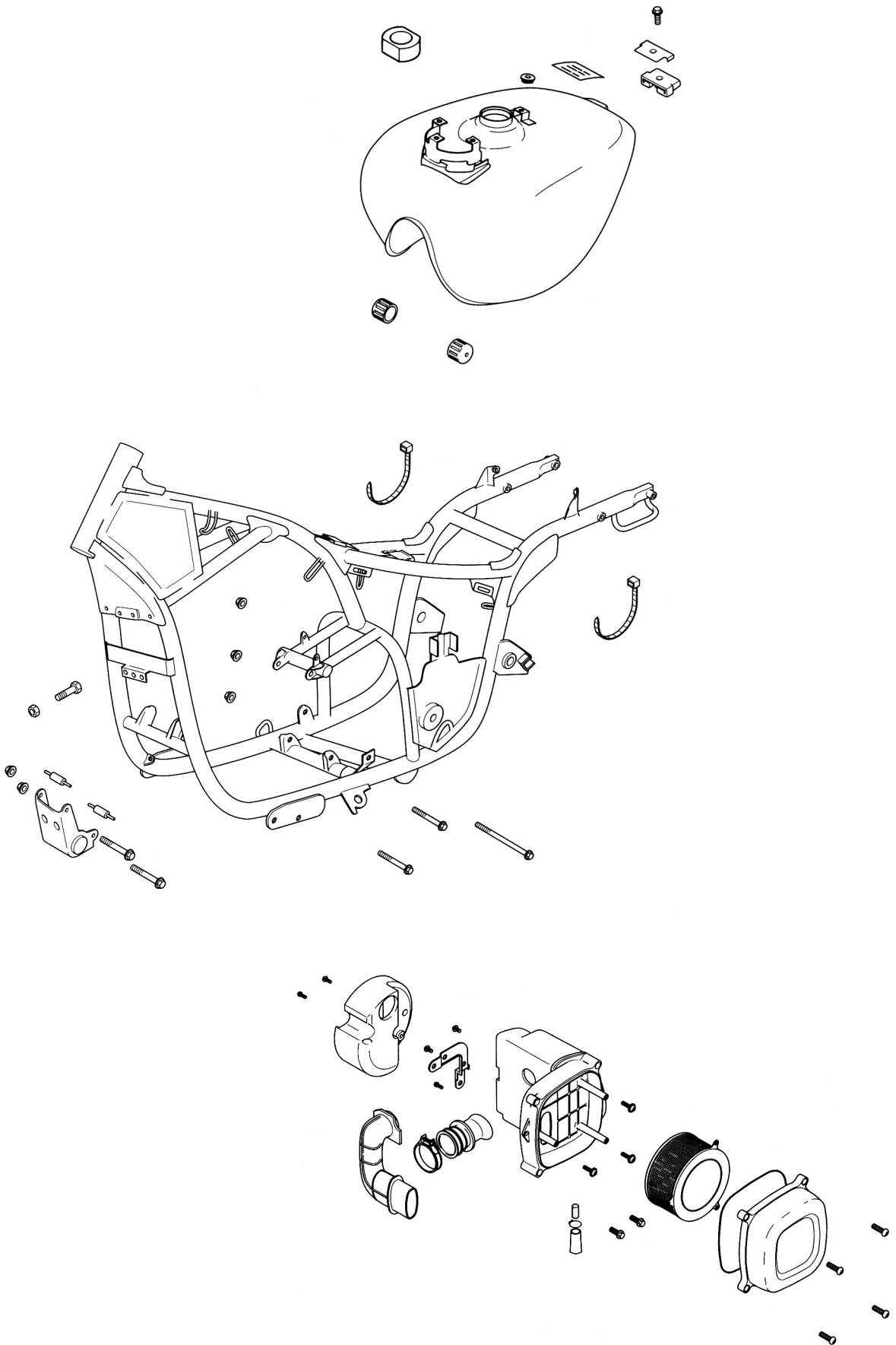

# 4. Fuel System

Service Information .....4-1	Throttle Valve .....4-5
Troubleshooting .....4-2	Carburetor .....4-6
Fuel Tank .....4-3	Accelerator Adjustment .....4-11
Air Cleaner Case .....4-4	

## Service Information

4

### General

**⚠WARNING**

- Gasoline is extremely flammable and is explosive under certain conditions.  
Work in a well ventilated area with the engine stopped. Do not smoke or allow flames or sparks in the area where gasoline is drained or stored and where the fuel tank is refueled.
- If the engine must be running to do some work, make sure the area is well ventilated.  
Never run the engine in an enclosed area. The exhaust contains poisonous carbon monoxide gas that may cause loss of consciousness and lead to death. Run the engine in an open area or with an exhausted evacuation system in an enclosed area.

**⚠CAUTION**

- Bending or twisting the control cables will impair smooth operation and may cause the cables stick or blind to result in loss of vehicle control.
- When disassembling fuel system parts, note the locations of the O-rings.
- Replace them with new ones on assembly.
- The float bowls have drain screws that can be loosened to drain residual gasoline.

### Specifications

Fuel Tank Capacity      17.3 l                      Reserve Fuel Capacity      2.9 l

**\*NOTE**

If the vehicle is to be stored for more than one month, drain the float chambers. Fuel left in the float chambers may cause clogged jet to result in hard starting or poor drive ability.

### Carburetor Specifications

Item	Specifications
Setting Mark	VL125 <b>B</b>
Main Jet	#102
Slow Jet	#38
Jet Needle Clip	Second
Float Level	19mm
Pilot Screw Initial Opening	2 ¼
Idle Speed	1,400 ±100(rpm)
Throttle Grip Free Play	2~6mm

### Tools

Float level gauge

## Troubleshooting

### Engine cranks but won't start

- No fuel in tank
- No fuel to carburetor
- Engine flooded with fuel
- Clogged air cleaner
- No spark at plug(Ignition system faulty)

### Rough idle, hard starting or stalling starting

- Incorrect idle ring adjustment
- Lean mixture, rich mixture
- Clogged air cleaner
- Faulty air cut off valve
- Clogged fuel system

### Lean mixture

- Clogged carburetor jets
- Clogged fuel tank breather
- Clogged fuel strainer screen
- Restricted fuel tube
- Faulty float valve
- Low float level

### Rich mixture

- Choke valve closed
- Faulty float valve
- Float level too high
- Clogged air jets

### Misfiring during acceleration

- Faulty accelerator pump



# Fuel Tank

## Removal

**⚠ WARNING**

- Gasoline is extremely flammable and is explosive under certain conditions. Work in a well ventilated area with the engine stopped. Do not smoke or allow flames or sparks in the area where gasoline is drained or stored and where the fuel tank is refueled.

- Loosen the speedometer cable screw.
- Remove the L. front side cover.
- Remove the seat. (⇒ 12-2)
- Turn the fuel cock OFF and remove the fuel tube.
- Remove a fuel tank mounting bolt.
- Remove fuel unit wire coupler.
- Remove the fuel tank.
- If there is not enough fuel supply from the fuel cock, drain the gasoline from the tank and clean the strainer screen after removing the fuel cock.

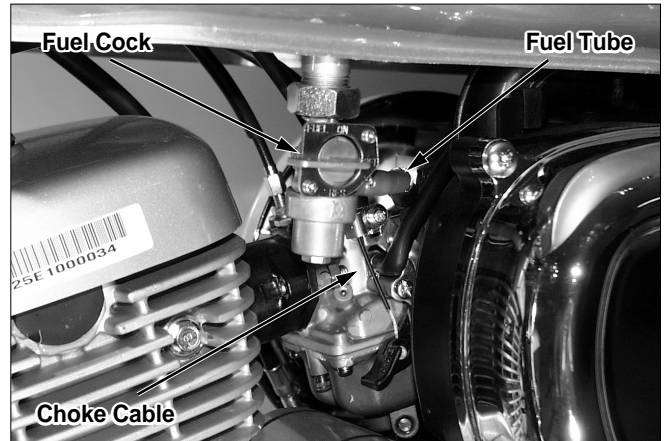

## Installation

- Install the fuel tank in the reverse order of removal.
- Check for the oil leakage.

**⚠ CAUTION**

- When the fuel is needed, the fuel alarm lamp is lighted.
- Fill the fuel at gas station.

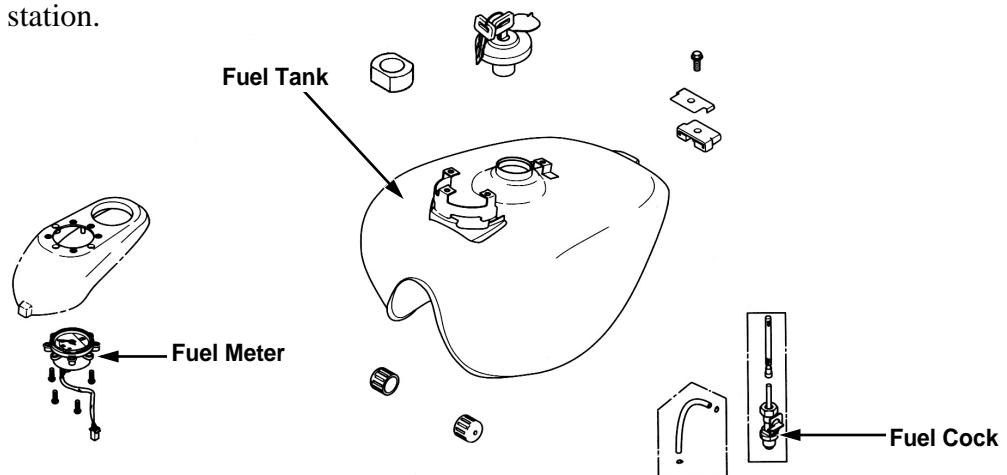

## Air Cleaner Case

### Removal

- Remove the L. side cover.
- Remove the air cleaner connecting tube band out of the air cleaner side. Remove the battery.
  
- Remove the air cleaner mounting bolt.
- Remove the air cleaner case.



### Installation

- Installation is essentially the reverse order of removal. Install the air cleaner case cover screw.

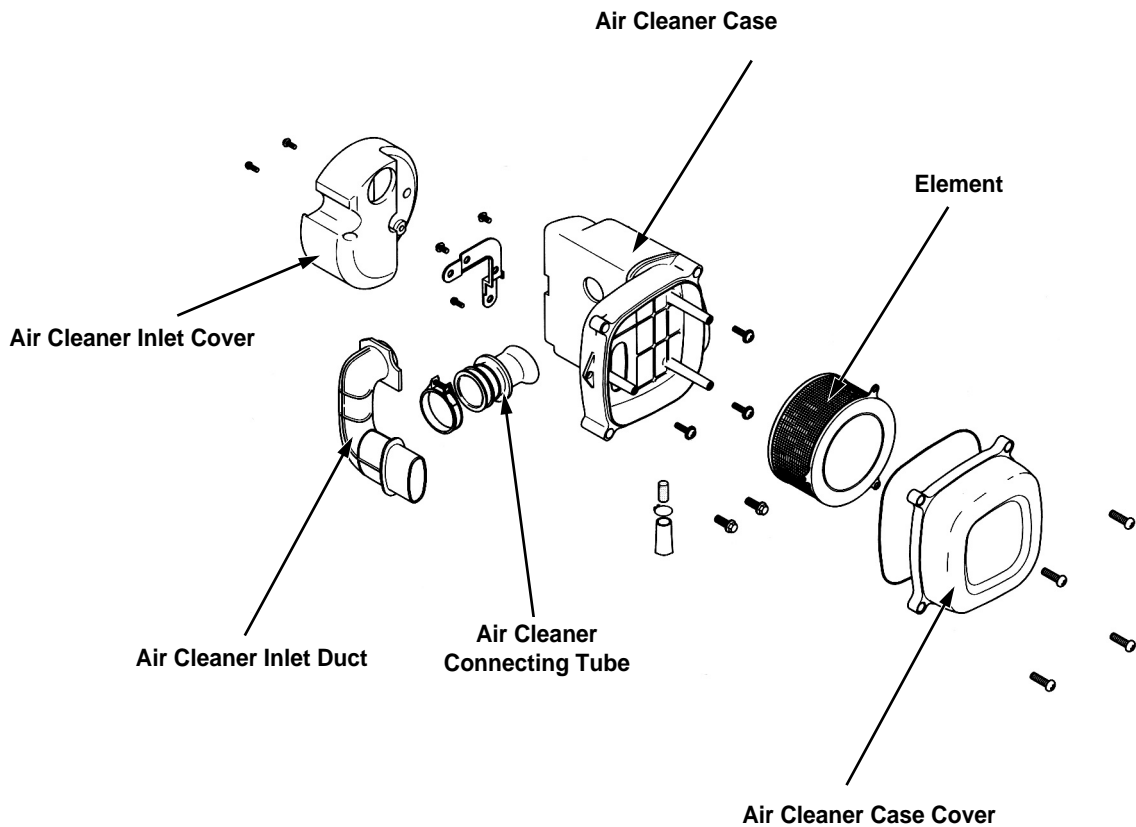

## Throttle Valve

### Removal

- Remove the R. side cover.
- Remove the seat and the fuel tank. Loosen the carburetor top slowly and remove the throttle valve.
- Remove the throttle cable connection out of the throttle valve, then remove the throttle valve.
- Remove the throttle valve spring, carburetor top out of the throttle cable.
- Remove the retainer clip and jet needle. Inspect the jet needle, throttle valve for damage and wear.

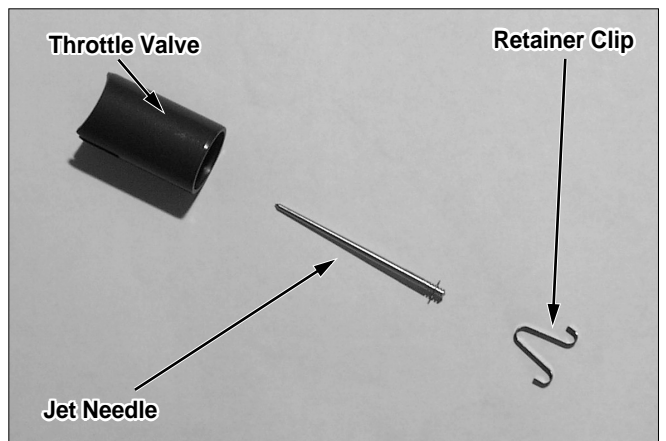
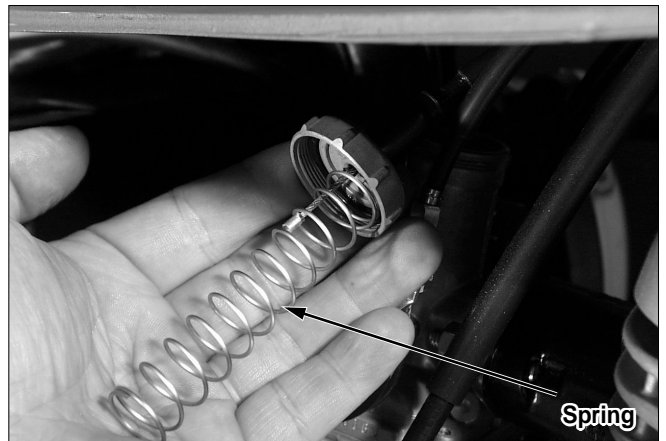
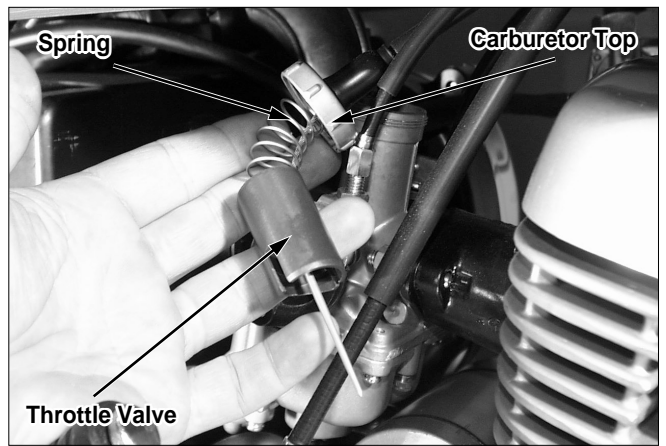
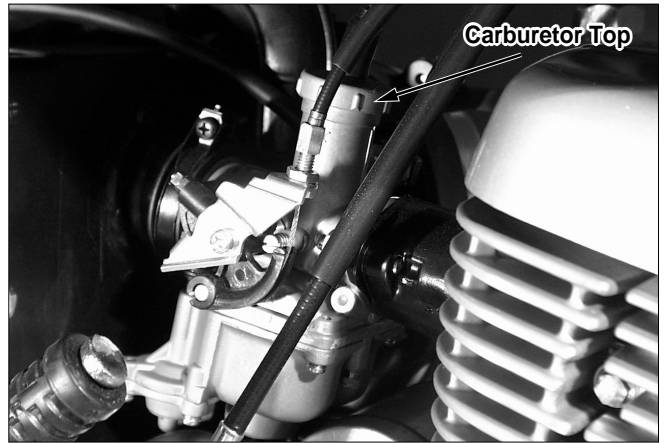

## Fuel System

### Installation

- Install the jet needle, retainer clip into the throttle valve.
- Needle clip standard position: 2nd Level
- Install the carburetor top, spring into the throttle cable.
- Install the throttle cable into throttle valve.

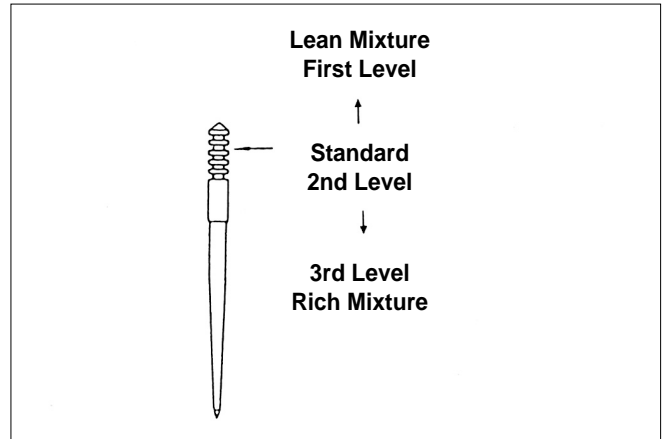

- Install the carburetor aligning the throttle valve groove with the throttle stop screw.
- Inspect the following items.
  - Throttle grip free play: 2~6mm
  - Idling speed:  $1,400 \pm 100$  rpm

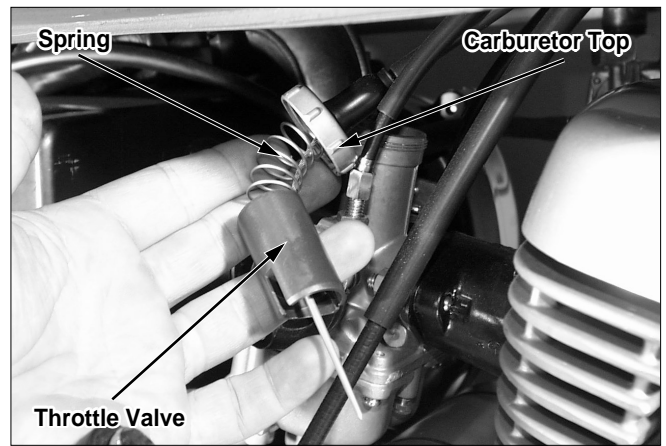

## Carburetor

### Removal

- Remove the fuel tank and seat (⇒ 4-3)
- Remove the carburetor top (⇒ 4-5)
- Remove the carburetor drain screw and drain gasoline from the carburetor.

#### ⚠ CAUTION

- Gasoline is extremely flammable and is explosive under certain conditions. Work in a well ventilated area with the engine stopped. Do not smoke or allow flames or sparks in the area where gasoline is drained or stored and where the fuel tank is refueled.
- Remove the choke cable.
- Loosen the air cleaner connecting tube band.

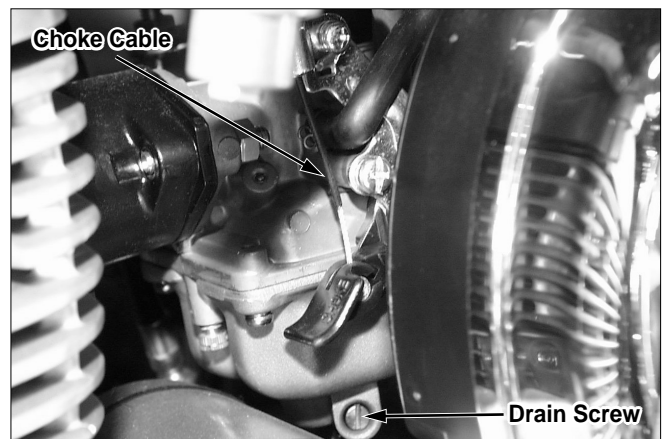
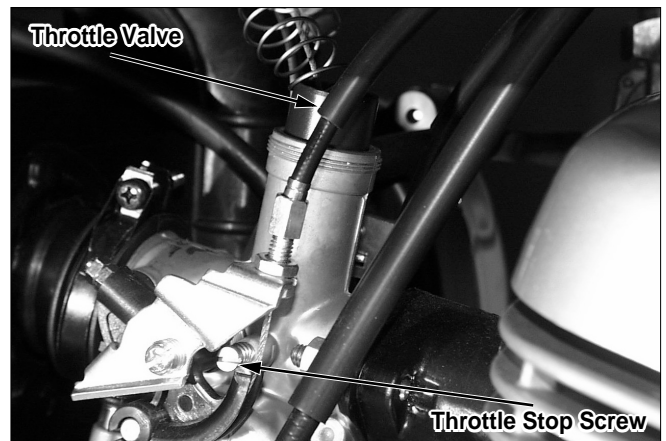

- Remove the throttle cable.
- Loosen the carburetor mounting nut, and remove the carburetor.



### Disassembly

- Remove the fuel and drain tube.

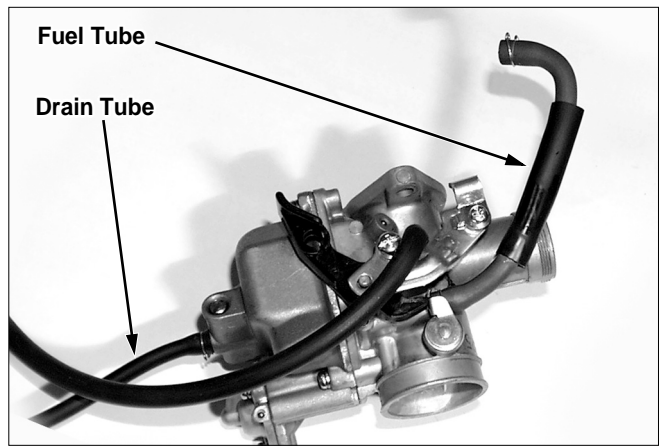

### Accelerator Pump

- Take of the 3 screws, and remove the pump cover.

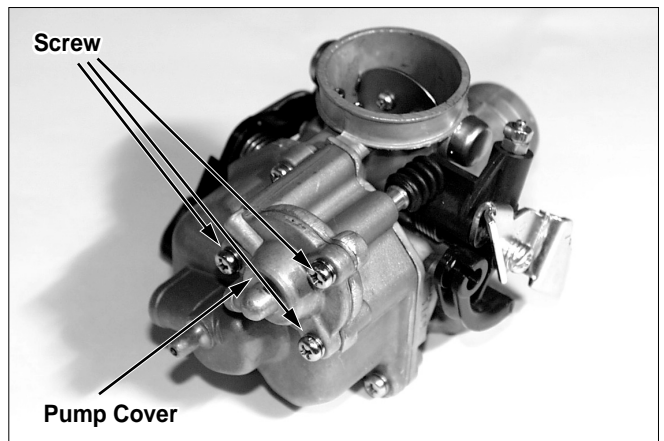

- Remove the spring.
- Inspect the damage of Accelerator pump rod and diaphragm. Blow the fuel pathway of diaphragm with air lightly and clean the clogged place.

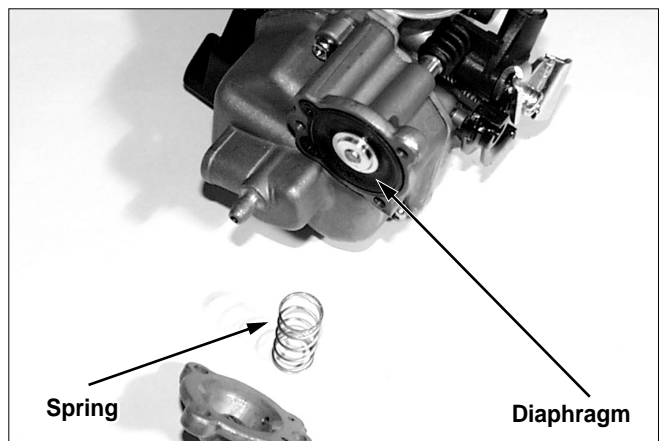

## Fuel System

- Align the diaphragm projecting part with float chamber groove. Install the spring to diaphragm cover, and install the cover to the float chamber preventing the diaphragm from damaging.
- Adjust the accelerator pump.

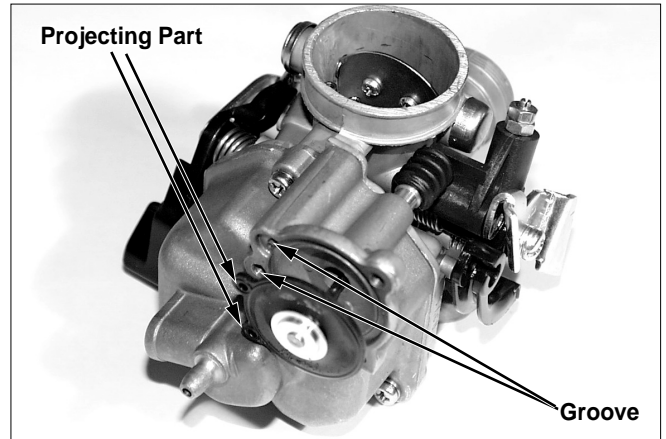

### Float, Float Valve

- Take off the 3 screws and remove the float chamber.

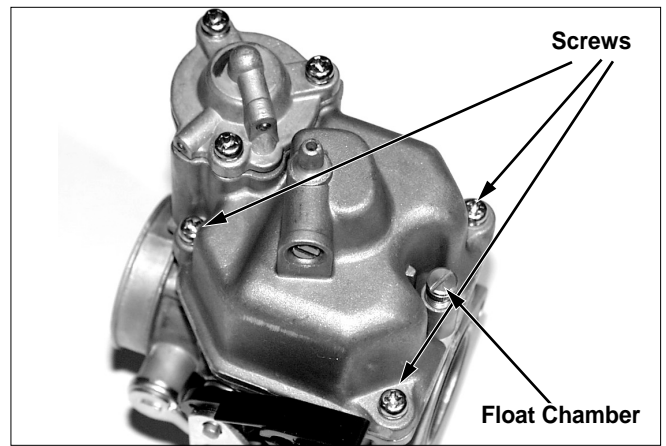

- Take off the float arm pin, and remove the float and float valve.

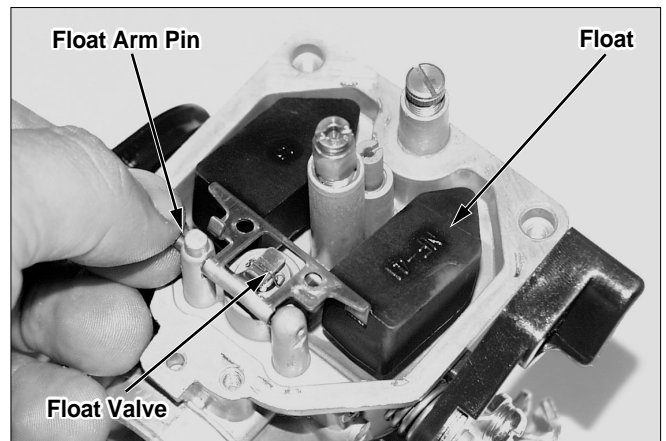

- Inspect the wear and tear of the part facing valve seat.
- Inspect transformation of float, and whether the gasoline is inhaled to the inside of float.

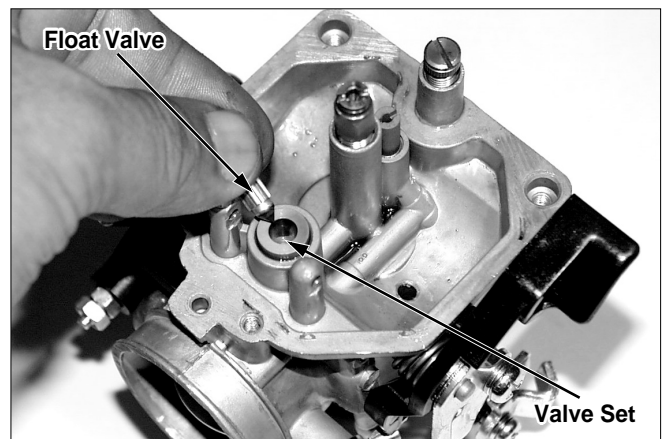

### Jet

- Remove the main jet, needle jet holder, and needle jet. Remove the slow jet, Remove the pilot screw after recording the number of turns until the pilot screw is tightened to clockwise completely.

**CAUTION**

- Do not tighten up the Pilot screws by force. It can cause the damaging of the seat part.
- Remove the throttle stop screws.
- Clean the jet with cleaning solvent.
- Inspect the pilot screws and jets and change the wear and tear parts with new ones.

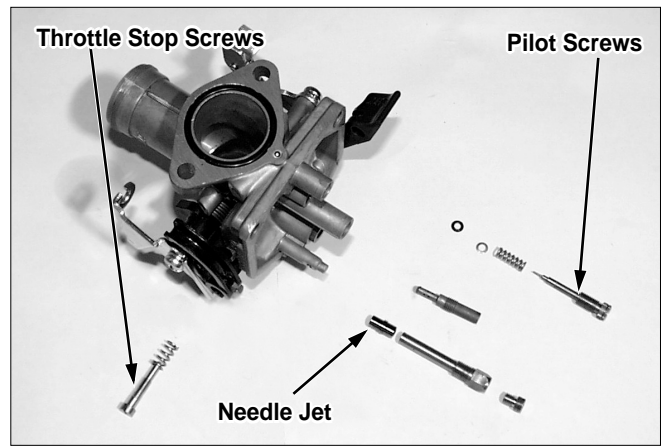
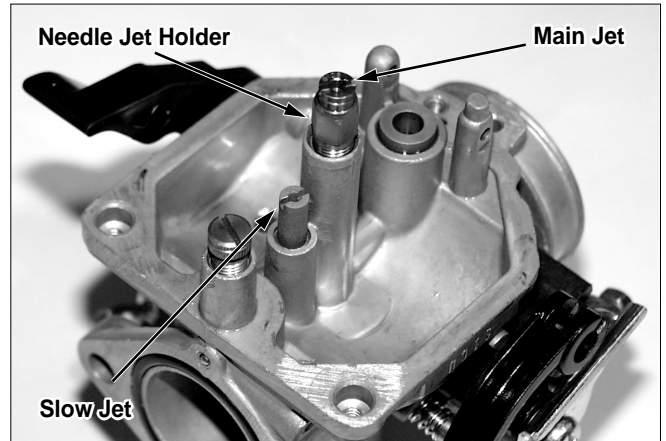

### Installation

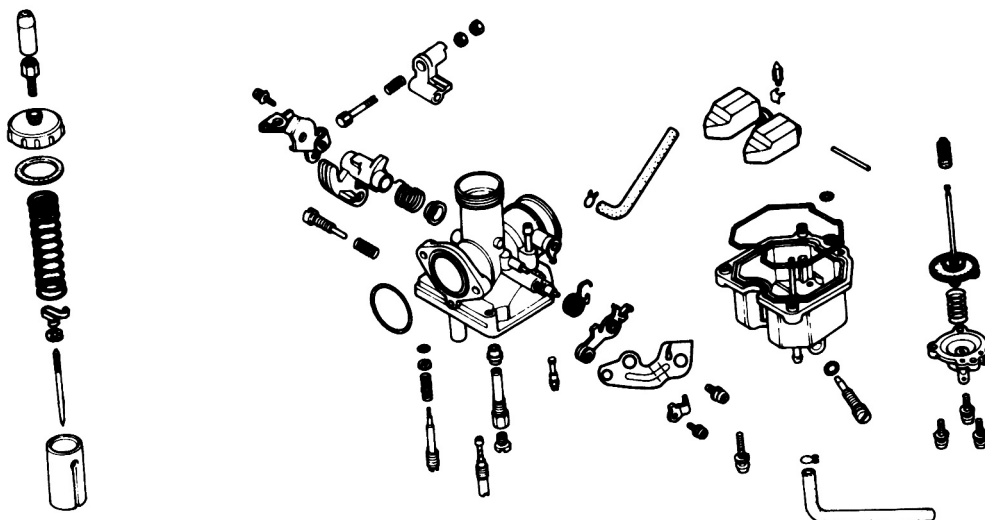

## Fuel System

- Blow each jet and body pathway with compressed air, and clean the clogged place.

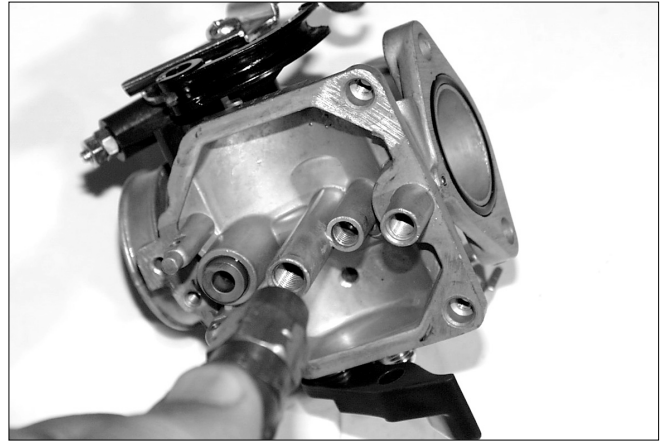

- Install the needle jet, needle jet holder, main jet and slow jet. Install the throttle stop screw and pilot screw.

### ⚠ CAUTION

- After tighten the pilot screw completely, back it out according to the recorded turns when removing.

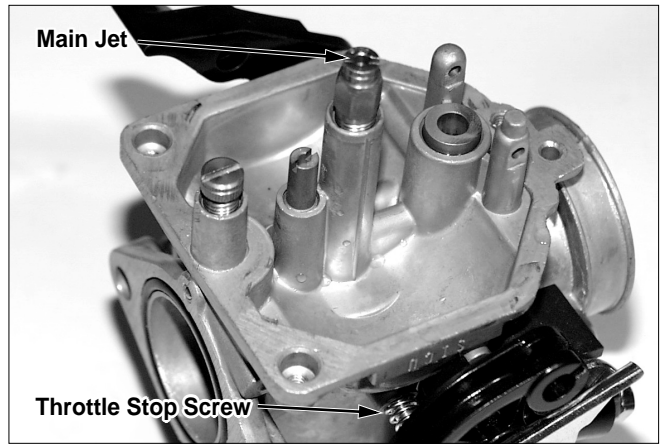

- If installing the new pilot screw, adjust the pilot screw.
- Install the float valve, float, and float arm pin.

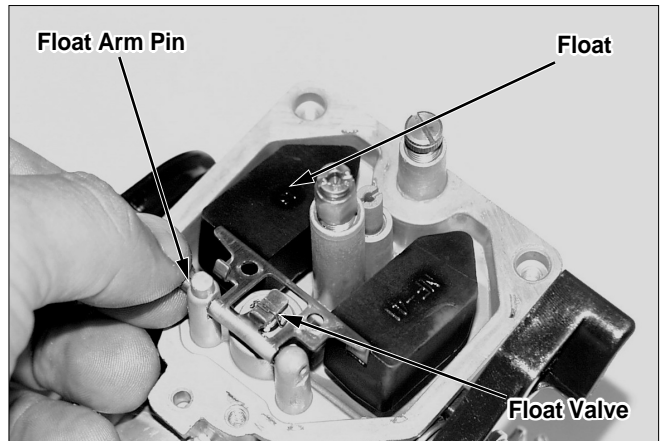

### Oil Level Adjustment

- Measure the oil level height in the state of contacting with float valve and float arm by inclining the carburetor.  
Standard Level: 19mm  
Tool : Float level gauge
- Check the smooth operation of float.





- Install the new o-ring to the float chamber groove.
- Install the float chamber and screws.

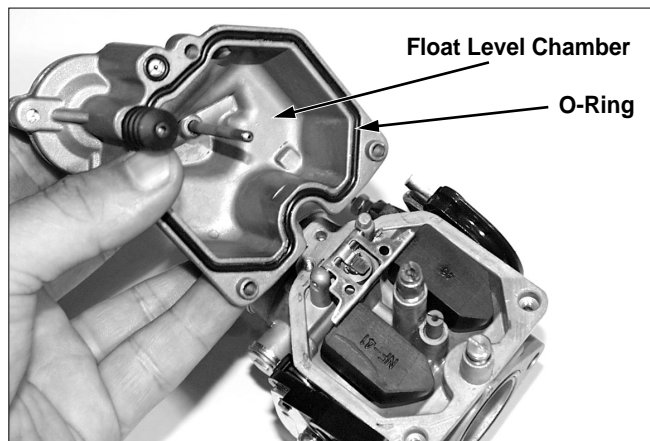

## Accelerator Adjustment

### ⚠ CAUTION

- Do not adjust unless replacing the adjuster screws.
- Adjust the idling. (⇒ 3-8)
- Adjust the operation of throttle grip. (⇒ 3-4)
- Loosen the lock nut, turn the adjuster screws to contact with accelerator pump cap, and then adjust the accelerator pump rod clearance.
- Tighten the lock nut.  
Clearance : 0mm (0in)

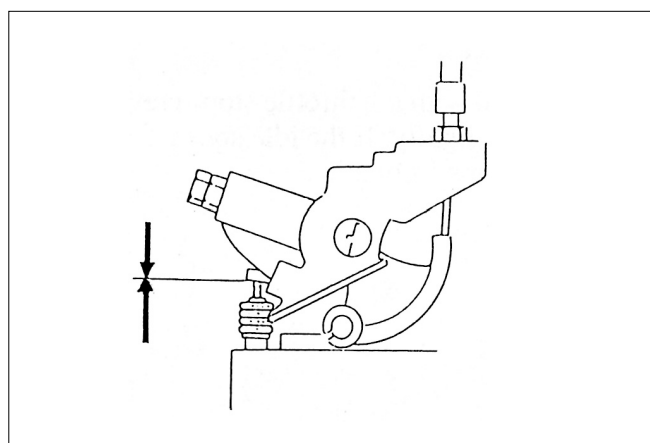

## Assembly

Install the fuel tube and drain tube.

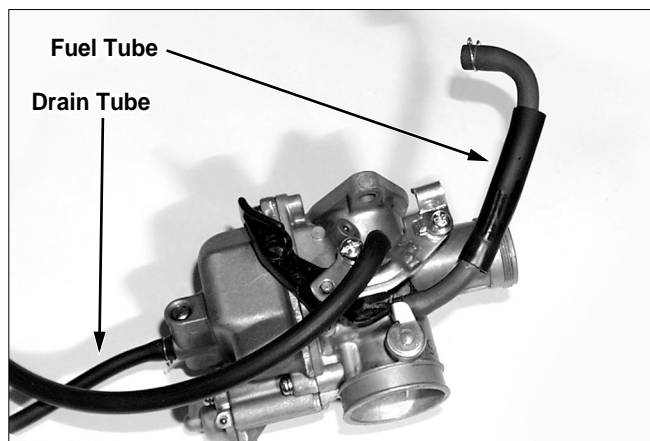

- Install the new o-ring into carburetor intake flange.
- Assemble the carburetor between carburetor insulator and connecting tube. Install the carburetor assembly nut and tighten the connecting tube bend screw.
- Connect the choke cable and throttle cable.
- Adjust the chock cable. (⇒ 3-5)
- Install the throttle valve. (⇒ 4-5)
- Adjust the throttle grip clearance. (⇒ 3-4)

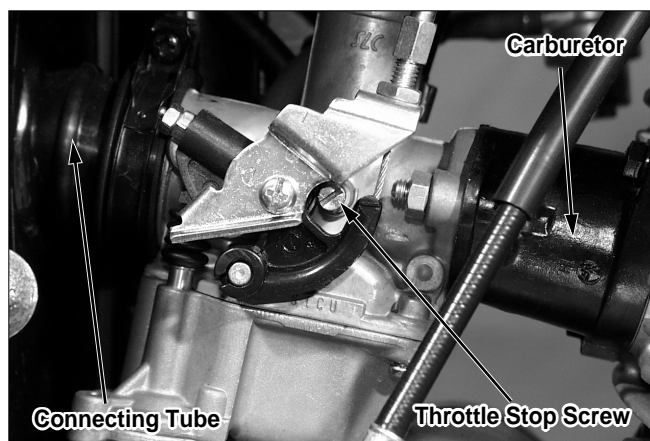

## Fuel System

---

### Pilot Screw Adjustment

1. Turn each pilot screw clockwise until it seats lightly and back it out to the specification given.

Initial Opening :  $2 \frac{1}{4}$

#### **CAUTION**

- Damages to the pilot screw seat will occur if the pilot screw is tightened against the seat.
2. Warm up the engine to operating temperature. Adjust the number of turns to the  $1,400 \pm 100$ rpm with the throttle stop screw.
  3. Turn the pilot screws out by  $\frac{1}{4}$  turn each until engine speed does not increase.
  4. Perform steps 2 and 3.
  5. Adjust the idle speed with the throttle stop screw.
  6. Pull the throttle grip lightly. If the idle speed changes, perform steps from 2 to 5.

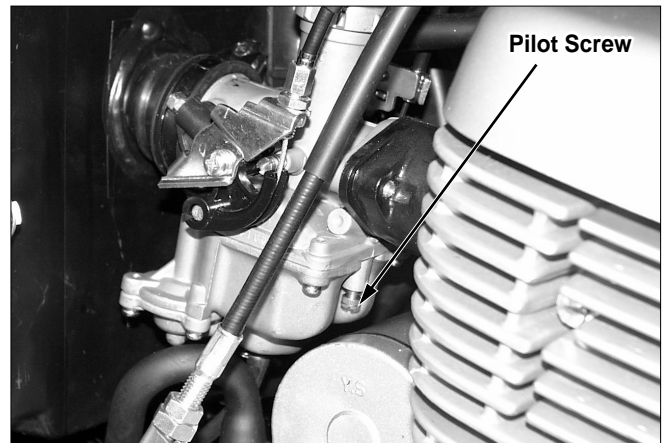

# 5. Engine Removal/Installation

Service Information .....	5-2	Engine Installation .....	5-4
Engine Removal .....	5-3		

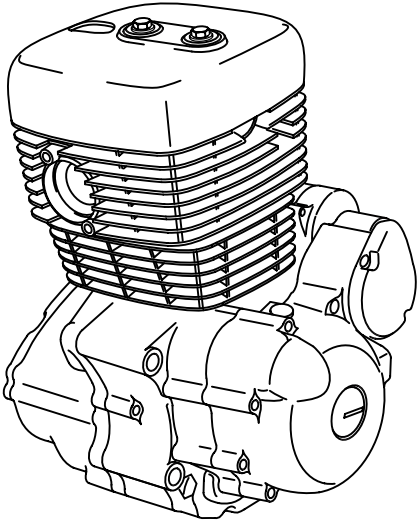
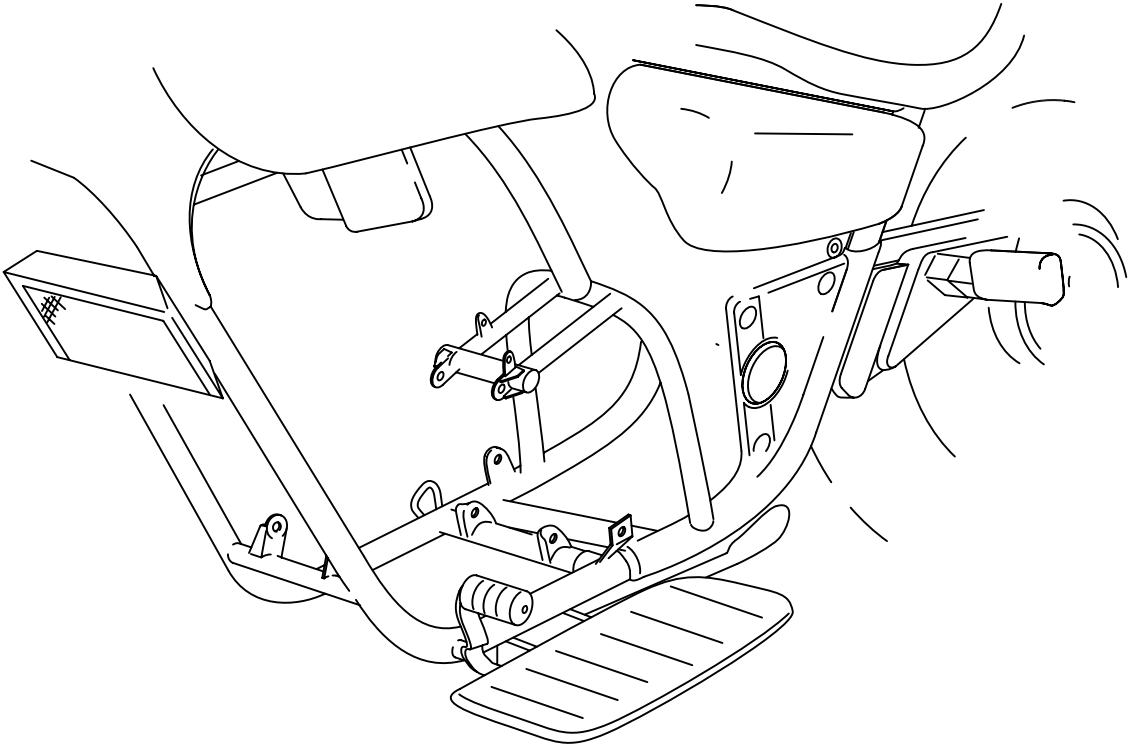

# Service Information

### General

- A floor jack or other adjustable support is required to support and maneuver the engine.  
Be careful not to damage the frame, engine body, cables, wire system.
- The following parts or components can not be served with the engine installed in the frame.
- Cylinder head, valve(⇒ Chapter 8)
- Cylinder, piston(⇒ Chapter 9)
- Transmission, kick starter(⇒ Chapter 10)
- Crank shaft(Chapter 10)

### Specification

- Engine oil capacity 1.2 l

### Torque Values

- Engine hanger bolt(Front 1) 2.7kgf-m(27N.m)  
(Front 1, Rear 2) 4.9kgf-m(49N.m)
- Gear change arm bolt 1.2kgf-m(12N.m)
- Drive sprocket bolt 1.2kgf-m(12N.m)

## Engine Removal

- Drain the engine oil.(⇒2-3)
- Remove the following
  - Side cover(⇒ 12-2)
  - Seat(⇒ 12-2)
  - Fuel tank(⇒ 4-3)
  - Mufflers(⇒ 12-3)
- Disconnect the connector of the starter motor cable, AC generator wire, gear change switch wire.
- Remove the battery negative cable, clutch cable, high tension code. Remove the carburetor.



- Remove the gear change pedal, L. rear cover drive sprocket cover.
- Remove the rear axle nut, drive chain adjuster.
- Remove the drive sprocket after pushing the rear wheel forward.

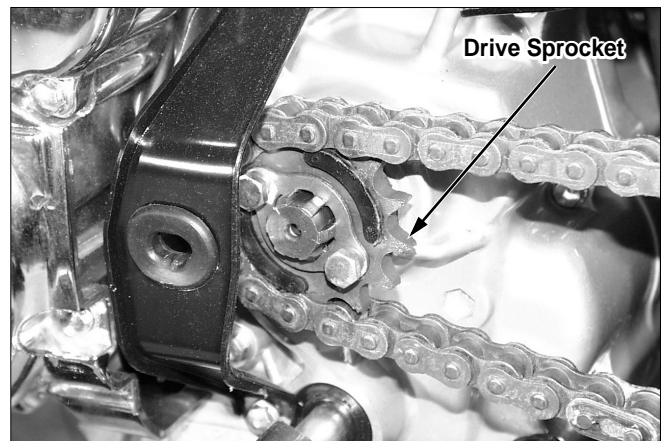

- Remove the front engine hanger bolt, engine hanger bracket.
- Remove the rear engine hanger bolt.

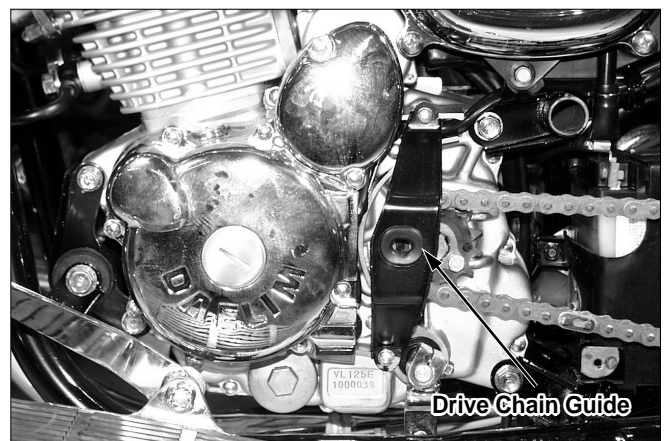

### Engine Installation

Engine installation is essentially the reverse order of removal.

**\* NOTE**

- Carefully align mounting points with the jack to prevent damage from mounting bolt threads and wire harness and cables.
- Be careful not to damage any part of the frame and bolt nuts.
- Be sure to install the cables, tubes, and wires to their correct positions(⇒ 1-11~13).

Torque

Engine hanger bolts:

(Front 1) 2.7kgf-m(27N.m)

(Front 1, Rear 2) 4.9kgf-m(49N.m)

Gear change arm bolt 1.2kgf-m(12N.m)

Drive sprocket bolt 1.2kgf-m(12N.m)

- Inspect the following after installing the engine.
  - Engine oil
  - Throttle grip operation
  - Clutch lever operation
  - Drive chain

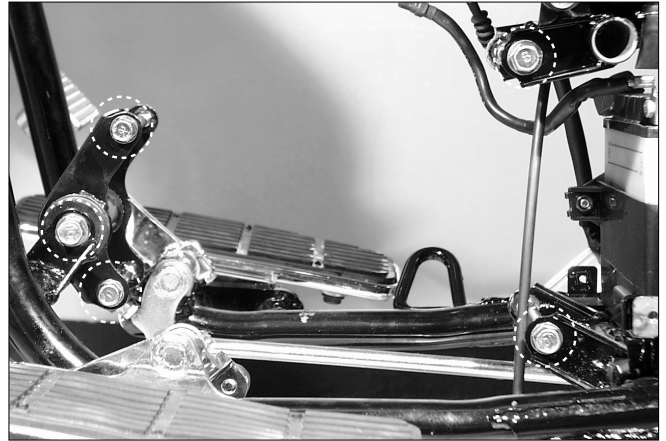

---

**MEMO**

---

---

---

---

---

---

---

---

---

---

---

A large, empty rounded rectangular box with a thin black border, intended for writing a detailed memo or note.

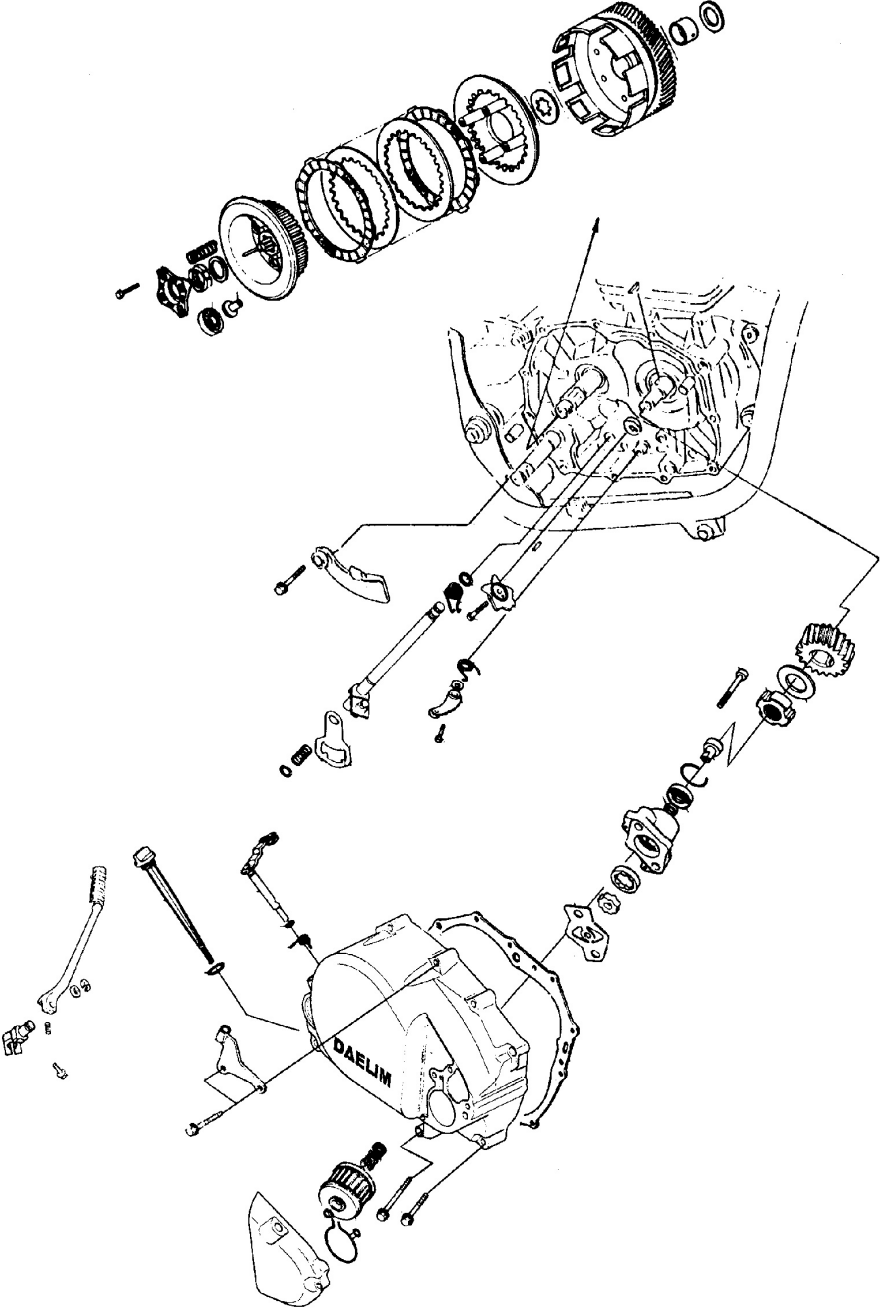



## 6. Clutch / Gearshift

<b>Service Information</b> .....	<b>6-1</b>	<b>Gearshift Linkage</b> .....	<b>6- 7</b>
<b>Troubleshooting</b> .....	<b>6-2</b>	<b>Clutch Installation</b> .....	<b>6- 9</b>
<b>R. Crankcase Cover Disassembly</b> ...	<b>6-3</b>	<b>Primary Drive Gear</b> .....	<b>6-10</b>
<b>Clutch Disassembly</b> .....	<b>6-4</b>	<b>R. Crank Case Cover</b> .....	<b>6-11</b>

### Service Information

- The clutch, gearshift linkage can be serviced with the engine in the frame.
- If the shift fork, drum and transmission require service, remove the engine and separate the crank case.
- The quality and level of fluid affect clutch operation. If the clutch slips, check the fluid level before servicing the clutch system.

6

### Specifications

Unit:mm(in)

Item		Standard	Service Limit
Clutch	Spring Free	35.5(1.40)	34.2(1.35)
	Disk Thickness	2.9~3.0(0.114~0.118)	2.6(0.10)
	Plate Warp	————	0.2(0.01)
	Clutch Outer O.D	28.000~28.013(1.1024~1.1029)	28.030(1.1035)
	Clutch Outer Guide(O.D.)	27.967~27.980(1.1011~1.1016)	27.950(1.1004)

### Torque Values

Clutch lock nut	6.5kgf-m(65N.m)-Apply engine oil
Drum stopper arm bolt	1.2kgf-m(12N.m)
Primary drive gear bolt	6.5kgf-m(65N.m)-Apply engine oil
Right crank case cover bolt	1.1kgf-m(11N.m)
Kick starter pedal bolt	2.2kgf-m(22N.m)

### Tools

#### Special

Clutch center holder

#### Common

Lock nut wrench  
 Extension bar  
 Flywheel holder

# Troubleshooting

Clutch operation problem can be corrected by adjusting a cable free play.

### Clutch lever pull too hard

- Damaged, clogged or sticking clutch cable
- Damaged lifter mechanism
- Damaged clutch lifter plate bearing
- Incorrect wiring of clutch cable

### Clutch slips

- Too big clutch lever free play
- Clutch plate warpage
- Clutch lock nut loose
- High fluid level or high fluid weight

### Clutch disengages

- Sticking lifter hydraulic system
- Worn disks
- Weak spring
- Too small clutch lever free play

### Difficult to thrust the gear level

- Incorrect clutch adjustment(too big free play)
- Bent shift fork
- Bent shift fork shaft
- Damaged gear shift spindle
- Damaged shift drum guide groove
- Damaged shift drum guide pin

### Gear jumps out

- Worn gear dog
- Bent shift fork shaft
- Damaged shift drum stopper
- Worn shift drum guide groove
- Worn gear shift fork groove

## R. Crankcase Cover

### Disassembly

- Drain the engine oil(⇒ 2-3)
- Remove the kick starter pedal.
- Remove the clutch adjusting lock nut and adjusting nut. Separate the clutch cable from the clutch arm.
- Remove the cable out of the cable holder.



- Remove the right crank case cover bolt and remove the cover.

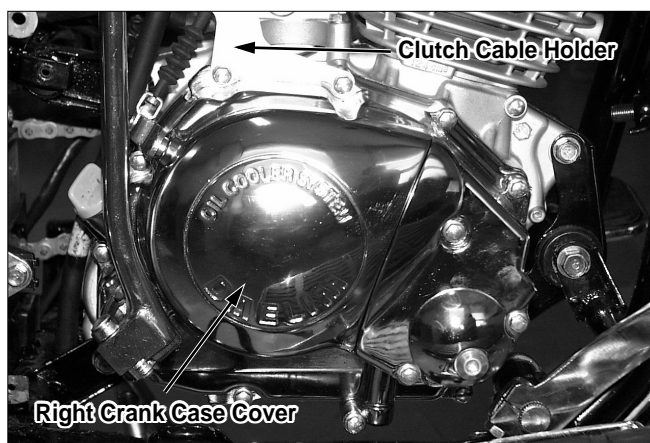

- Remove the dowel pins and gasket.

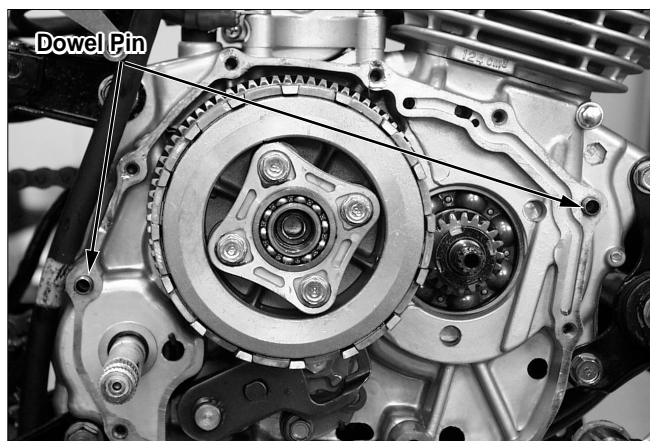

### Clutch Arm/Lift Shaft Removal

- Remove the lifter rod, and separate the clutch arm/lift Shaft and clutch arm spring from the R. crank case cover.

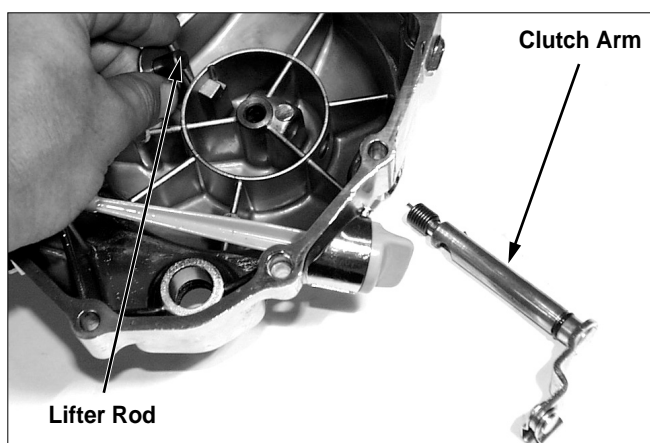

## Clutch, Gearshift

- Separate the clutch arm spring and o-ring from the clutch arm/lifter shaft.
- Inspect the wear and damage of the lifter rod and clutch arm/lifter shaft.
- Inspect the wear and damage of the clutch arm spring.

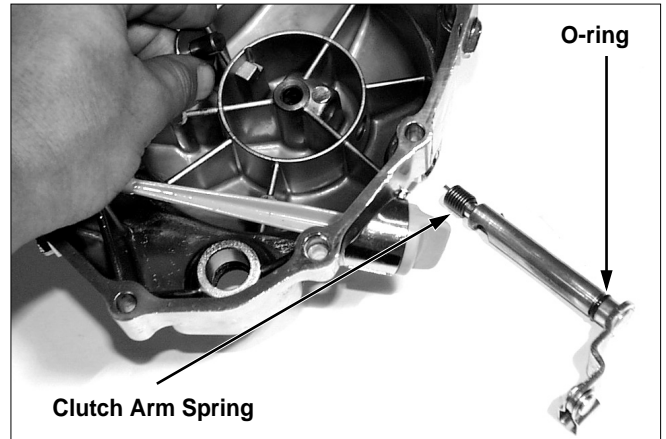

### Clutch Arm/Lifter Shaft Assembly

- Coat the new o-ring with grease, and assemble the clutch arm/lifter shaft. Install the clutch arm spring to the clutch arm/lifter shaft.
- Install the spring ends into the hole of the lifter shaft.

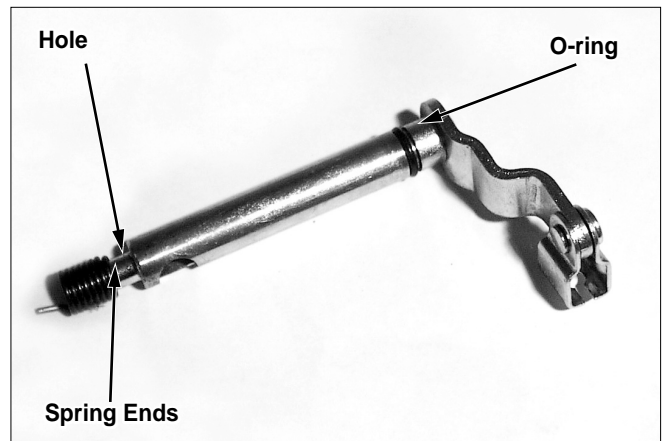

- After installing the clutch arm/lifter shaft into the R. crankcase cover, turn the clutch arm to the right and install the lifter rod aligning the shaft with cover hole.

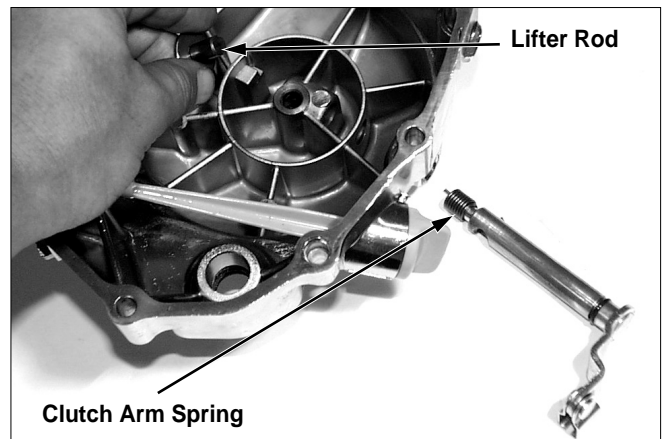

### Clutch Disassembly

- Remove the following
  - Clutch spring bolts
  - Clutch lifter plate
  - Clutch spring

#### \*NOTE

- Loosen the clutch spring bolt in a crisscross pattern in two or three steps and remove the bolts.

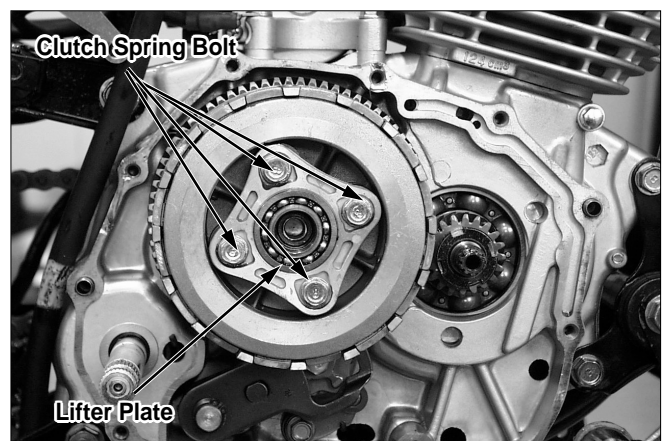

- Press the clutch center using the clutch center holder and remove the clutch lock nut.

Tools:

Clutch Center Holder  
Lock Nut Wrench, 20 × 24mm  
Extension Bar

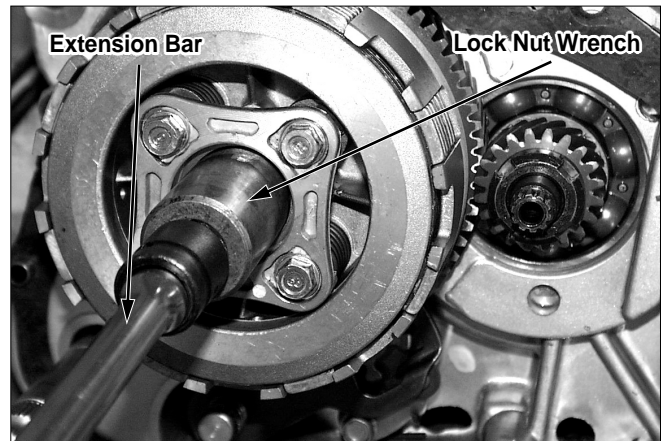

- Remove the lock washer.
- Remove the clutch center, disk, plate, and pressure plate.

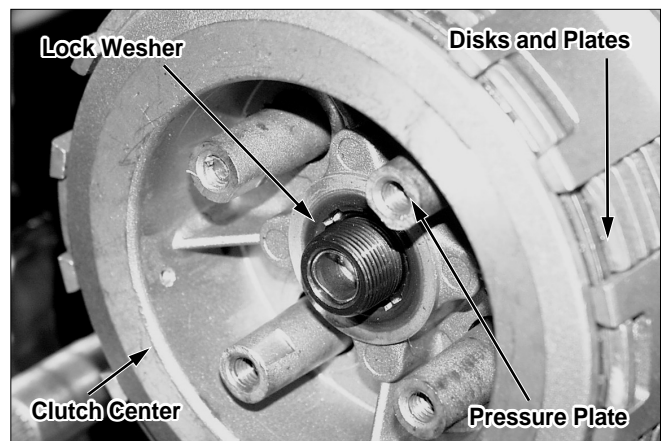

- Remove the spline washer and clutch outer.

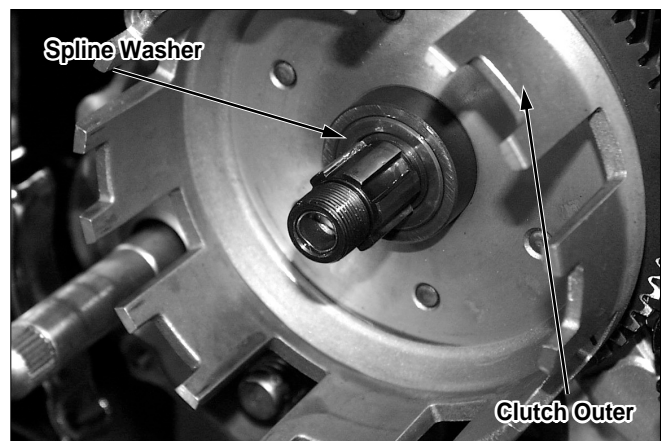

- Remove the clutch outer guide and thrust washer.

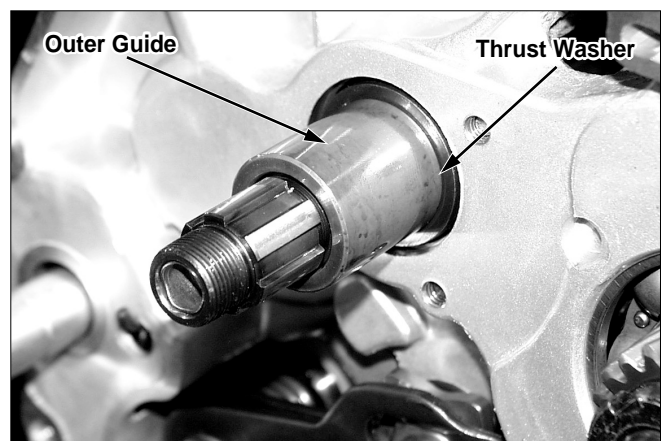

## Clutch, Gearshift

### Inspection

- Inspect the lifter plate bearing for scoring and other damage.
- Inspect the lifter plate for damage.
- If necessary, replace them.

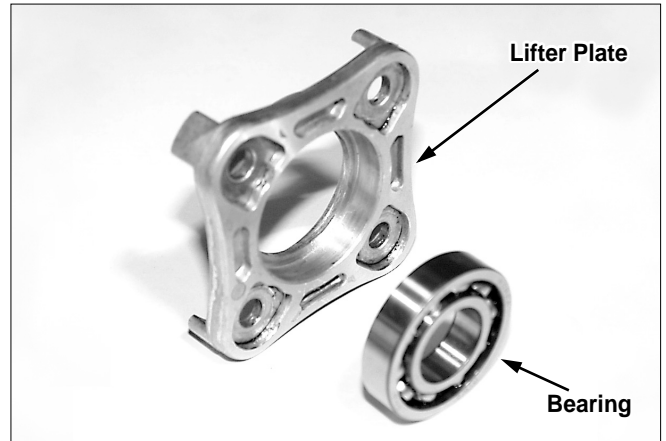

- Measure the clutch spring free height.
- Service Limit: 34.2mm(1.35in)

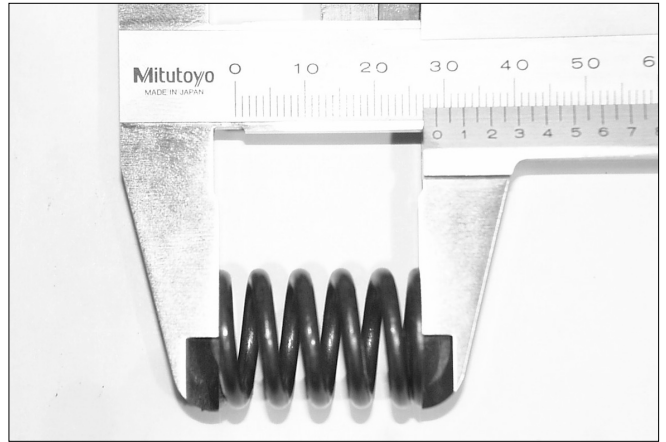

- Check the clutch disk. If necessary, replace it.
- Measure the disk amplitude.  
Service Limit: 2.6mm(0.10 in)

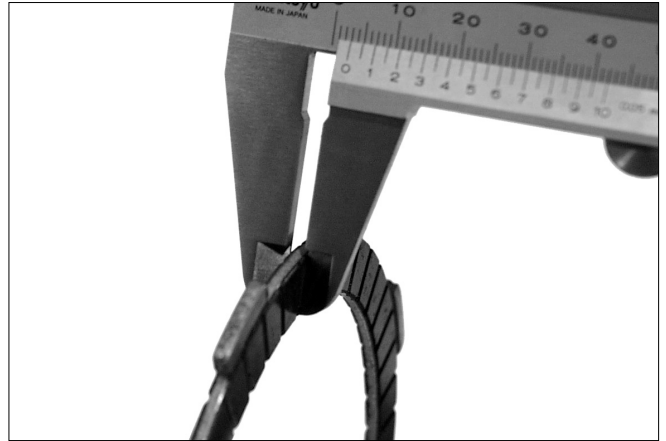

- Check the plate for warpage on a surface plate, using a feeler gauge.  
Service Limit: 0.2mm(0.01 in)

#### \* NOTE

- If any of the disk and plate requires replacement, it must be replaced as a set.



- Check the slots  $\square$  in the clutch outer for nicks or indentations made by the clutch discs. If necessary replace them.
- Measure the clutch outer inside diameter.  
Service Limit:28.030mm(1.1035in)
- Measure the clutch outer guide outside diameter.  
Service Limit:27.950mm(1.1004in)

### Installation

- Installation is essentially the reverse order of removal.

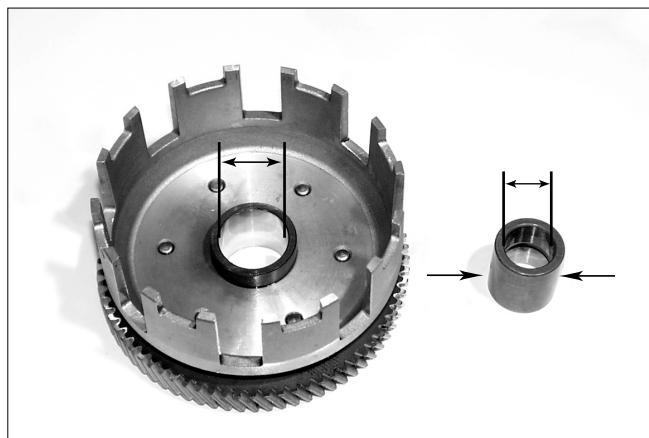

## Gear Shift Linkager

### Removal

- Remove the following:
  - Gear change pedal from the gear shift spindle
  - Right crank case cover
  - Clutch ass'y



- Remove the gear shift spindle and thrust washer.

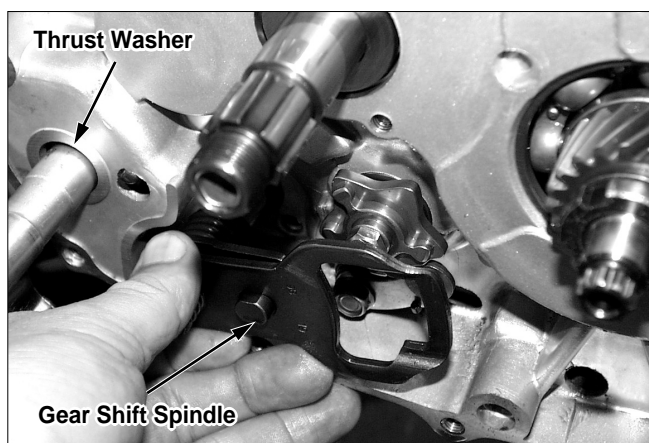

- Remove the gear shift cam bolt, cam, and dowel pins.
- Remove the drum stopper arm bolt, stopper arm, collar, and spring.

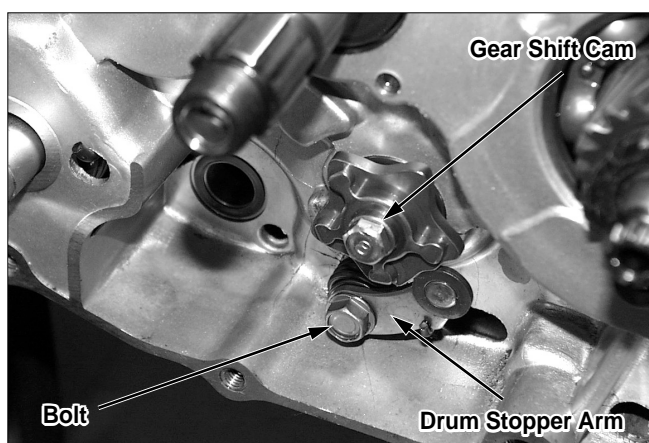

## Clutch, Gearshift

### Inspection

- Check the gear shift spindle for wear or damage.
- Inspect the gear shift plate for deformation, wear, or other damage.
- Check the return spring and gear shift plate spring for wear or damage.

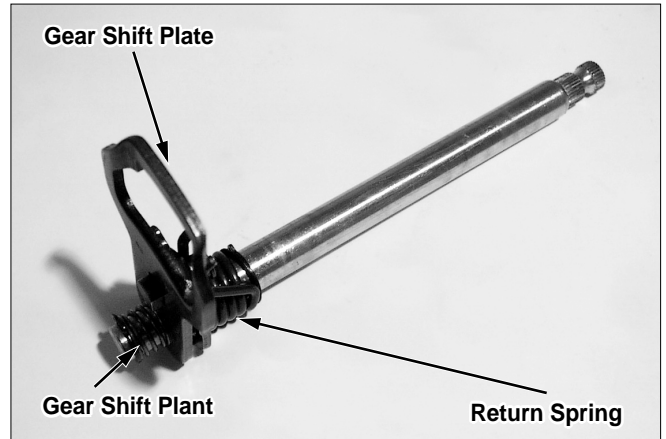

### Installation

- Install the drum stopper arm collar, spring, stopper arm, and bolt. Tighten the bolts.  
Torque: 1.2kgf-m(12N.m)

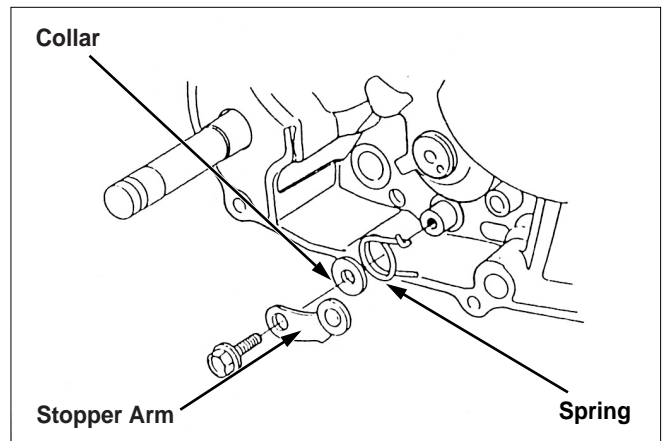

- Press the stopper arm, and install the cam, aligning the dowel pin with the gear shift hole.

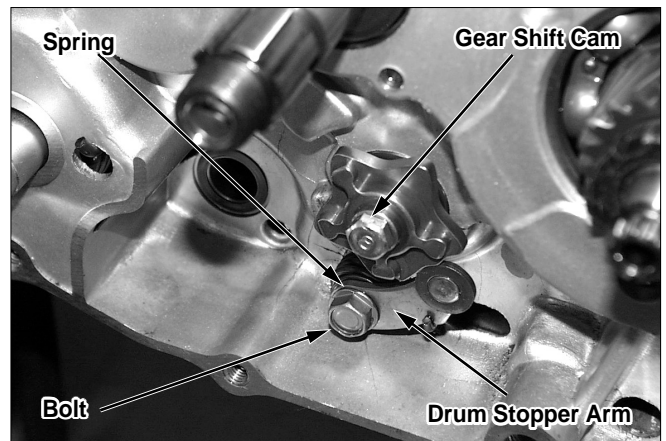

- Install the thrust washer into the gear shift spindle.
- Install the gear shift spindle into the crank case, aligning the teeth of the return spring with the tappet of the right crank case as shown.

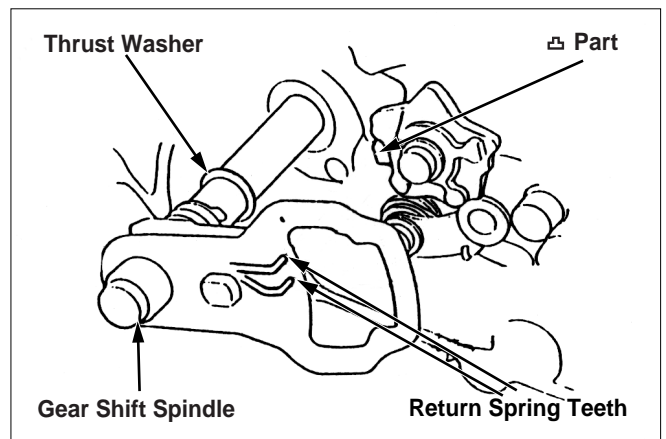



- Install the following:
  - Clutch assy.
  - R. crank case cover
- Install the gear shift arm into the gear shift spindle



### Clutch Assembly

- Coat the clutch outer guide with clean engine oil.
- Install the thrust washer and outer guide into the main shaft.

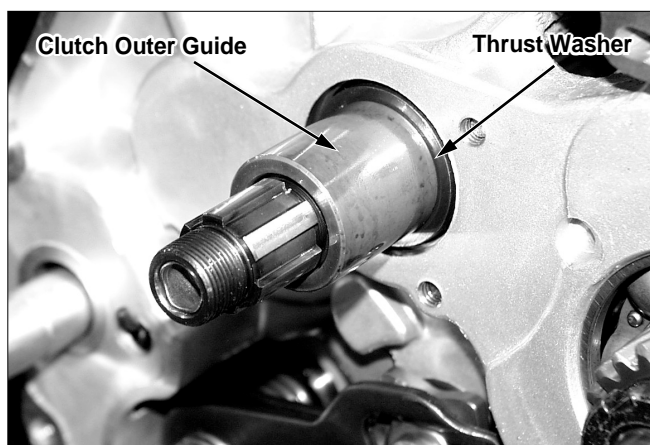

- Install the clutch outer and spline washer.

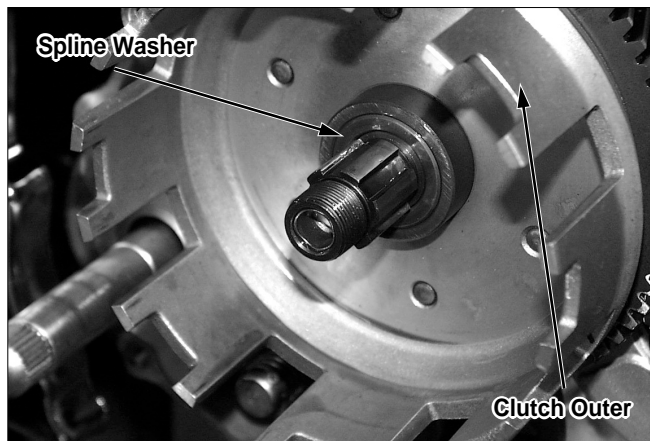

- Coat the clutch and plate disk. With clean engine oil.
- Install the 6 disk. and 5 plates to the clutch center by turns.

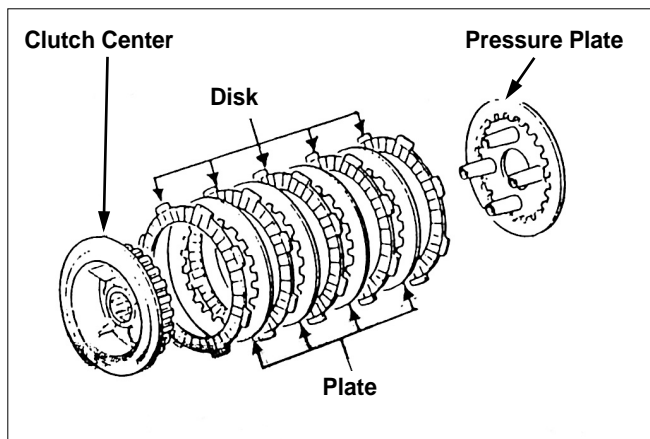

## Clutch, Gearshift

- Install the pressure plate, disk, plate and clutch center into the clutch outer.
- Coat the nut parts with clean engine oil, and tighten the lock nut.



- Install the lock nut by pressing clutch center into the clutch center holder.  
Torque : 6.5kgf-m (65N.m)  
Tools:  
Clutch center holder  
Lock nut wrench, 20 × 24mm  
Extension bar
- Install the clutch spring, lifter plate and clutch spring bolt diagonally several times.

### \*NOTE

- Check if the pressure plate press the disc, and plate exactly.

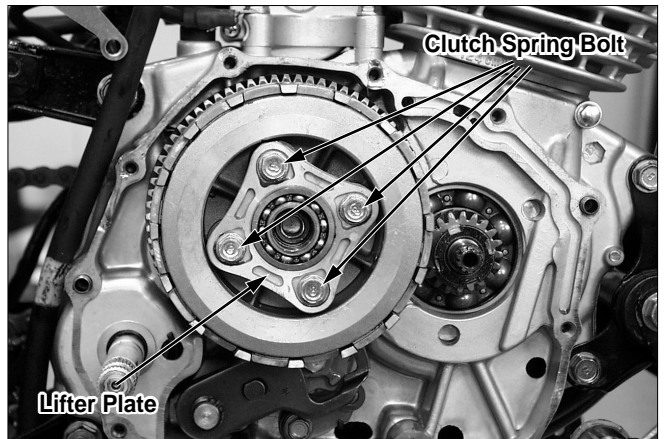
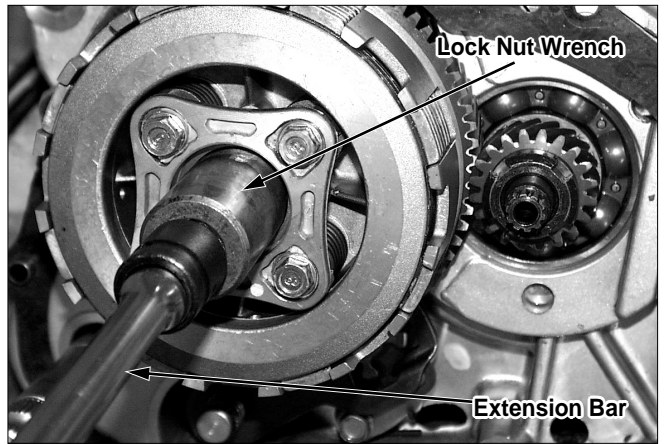

## Primary Drive Gear

### Removal

- Remove the crank case.
- Hold the flywheel using a flywheel holder.
- Remove the primary drive gear lock nut.  
Tools:  
Flywheel holder  
Lock nut wrench, 20 × 24mm  
Extension bar
- Remove the lock nut, primary drive gear, and woodruff key.

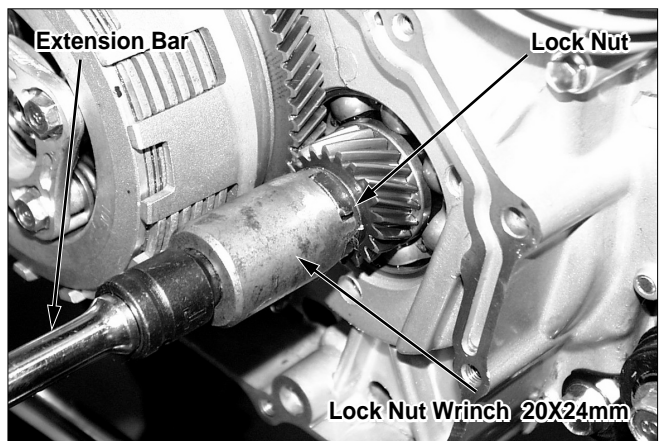

- When replacing the primary drive gear, select the gear which the paint mark, same color of R.crank case paint mark, is indicated.

Paint mark of crank case    Paint mark of primary drive gear

White	←→	White(Primary drive gear A)
Blue	←→	Blue(Primary drive gear B)
Yellow	←→	Yellow(Primary drive gear C)

#### ⚠ CAUTION

- Select the correct gear. If not install the correct gear, the back-lash between the drive gear and driven gear is out of regulation and the noise of gear occur.

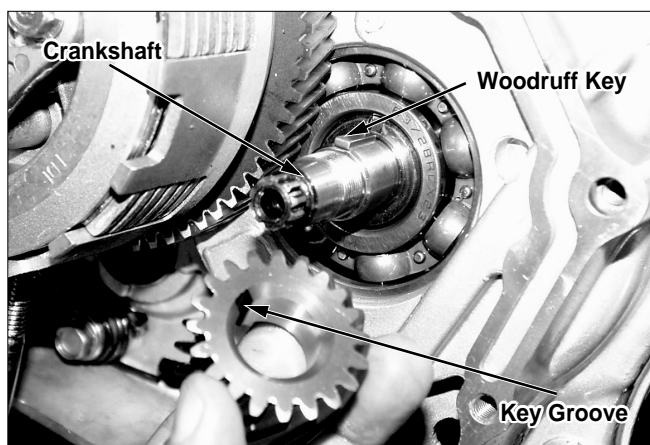

### Installation

- Install the woodruff key into the key groove of the crankshaft.
- Align the primary drive gear key groove with the crankshaft key and install the gear.
- Install the washer.
- Coat the nut with clean engine oil, and tighten the lock nut.

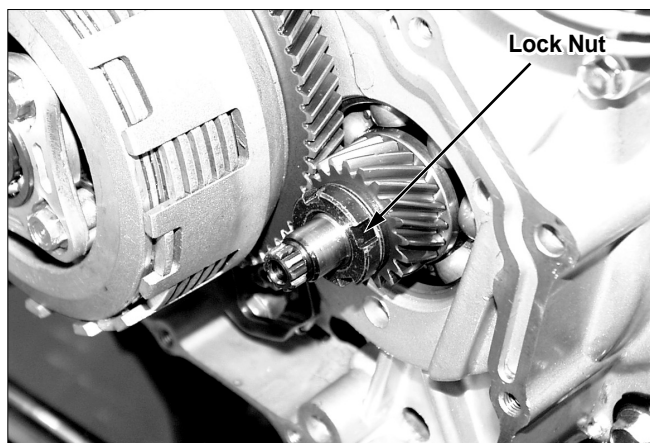

- Hold the flywheel with a flywheel holder.
- Tighten the primary drive gear lock nut.  
Torque : 6.5kgf-m(65N.m)

Tools:

Flywheel holder  
Lock nut wrench, 20 × 24mm  
Extension bar

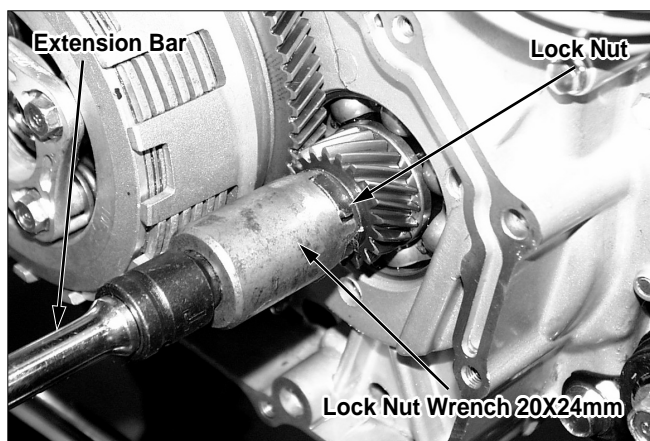

## R. Crankcase Cover

### Installation

- Remove the gasket from the crank case surface.
- Install the dowel pins and a new gasket.

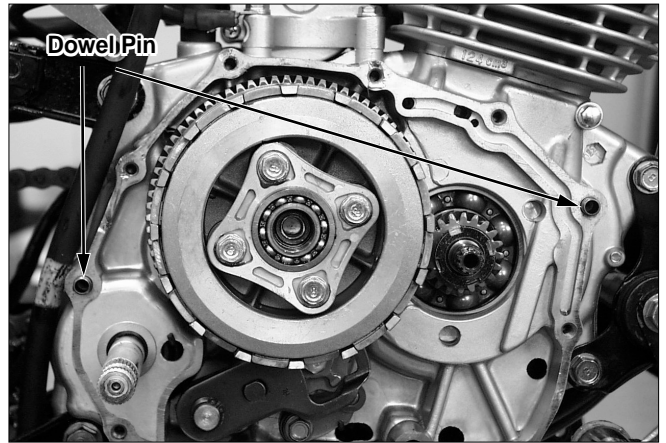

- Install the right crank case cover, aligning the spline of the crank shaft and with the oil pump shaft spline.

#### \*NOTE

- If any difficulty is encountered in joining the crank shaft spline to the oil pump shaft spline, remove the crankshaft hole cap, then install the right crank case cover while turning the crankshaft to the right slowly.

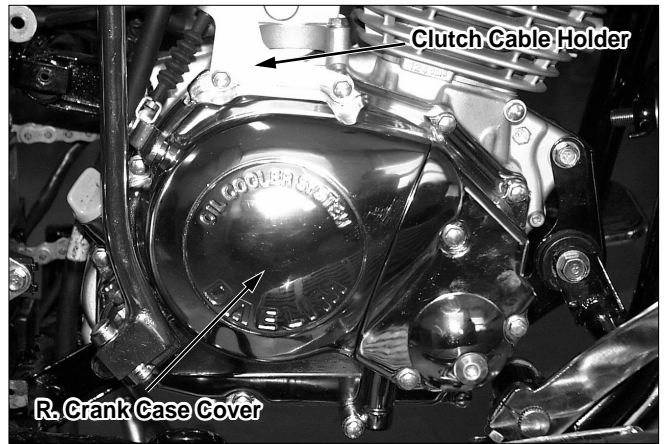

- Install the clutch cable holder and crank case cover bolt.

Torque: 1.1kgf-m(11N.m)

- Install the clutch cable into the clutch cable holder.
- Align the end of the cable with the clutch arm.
- Check the clutch cable free play(⇒ 3-12)
- Install the kick starter pedal and tighten the bolt.

Torque: 2.2kgf-m(22N.m)



- Fill the crankcase with the recommended oil (⇒ 2-3)

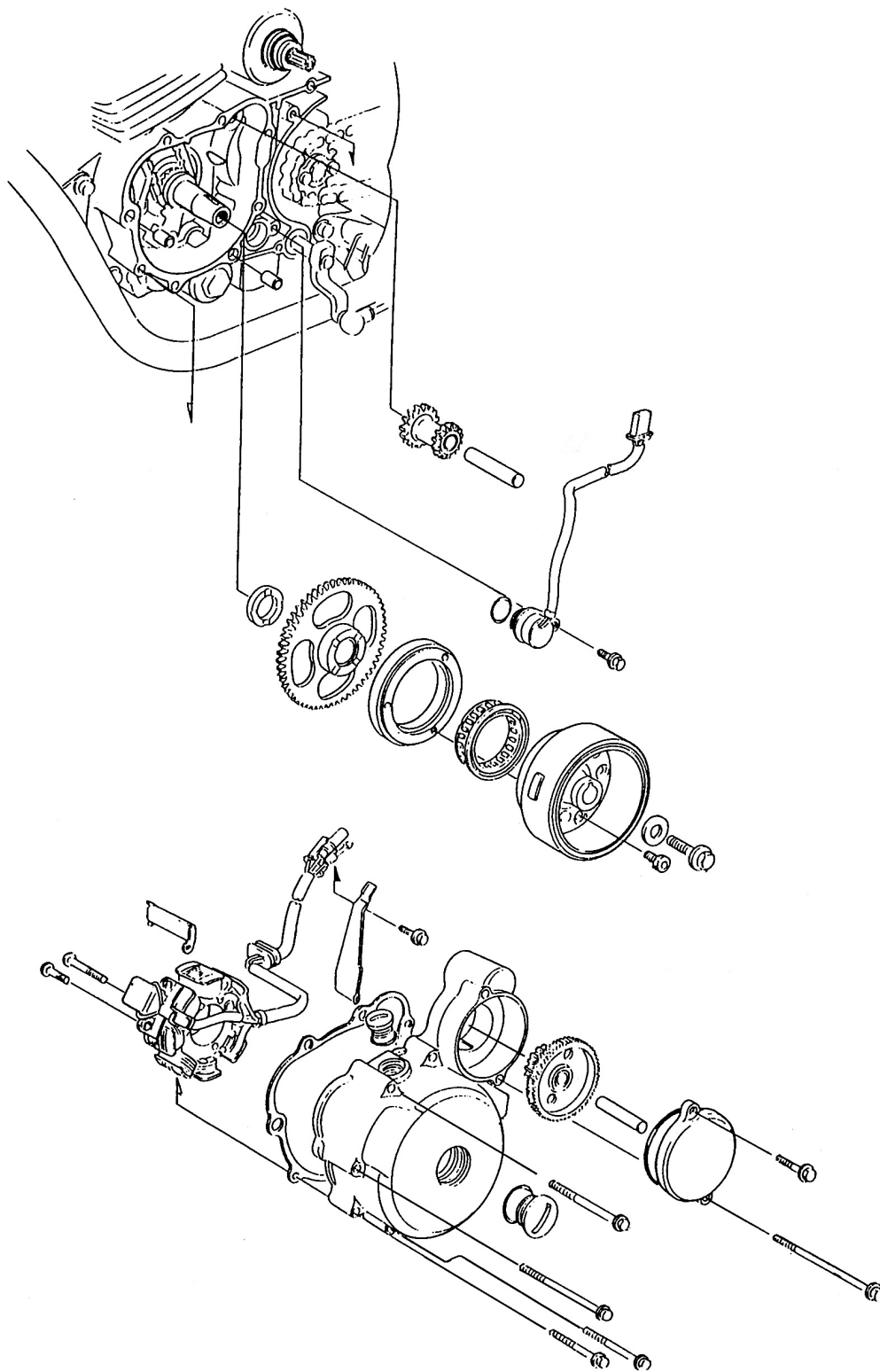

## 7. A.C Generator / Starter Clutch

<b>Service Information</b> .....	<b>7-1</b>	<b>Starter Clutch</b> .....	<b>7-7</b>
<b>A.C Generator</b> .....	<b>7-2</b>		

### Service Information

#### General

- This section covers removal and installation of the A.C. generator.
- Refer to section 16 for inspection of the A.C. generator.
- The A.C. generator/starter clutch service may be done with the engine in the frame.

#### Specification

Unit:mm(in)

Item		Standards	Service Unit
Starter Driven Gear	O.D.	42.195 - 42.208(1.6612-1.6617)	42.180(1.658)
	I.D	22.022 - 22.010(0.8670-0.8665)	22.100(0.870)
Starter Idle Gear	I.D	10.045 - 10.028(0.3942-0.3948)	10.100(0.393)
Starter Idle Gear Shaft	O.D	9.991 - 10.100(0.3933-0.3937)	9.97(0.393)
Reduction Gear	I.D	10.013 - 10.045(0.3942-0.3955)	10.100(0.393)
Reduction Gear Shaft	I.D	9.991 - 10.100(0.3933-0.3937)	9.97(0.393)

#### Torque Values

Flywheel Bolt	5.5kgf-m(55N.m)
Starter Clutch Socket Bolts	3.2kgf-m(32N.m)
Left Crank Case Cover Bolt	1.1kgf-m(11N.m)

#### Tools

##### Common

Flywheel Puller  
Flywheel Holder

### A.C Generator

#### Removal

- Remove the gear change pedal.
- Remove the L. lower cover.



- Loosen the one bolt attaching A.C. generator and remove the A.C. generator wire clamp.



- Disconnect the coupler of the A.C. generator wire, gear change switch wire coupler.



- Loosen the 3 bolts and remove the starter reduction gear cover.



- Remove the starter reduction gear shaft and starter reduction gear.



- Loosen the left crank case cover adjusting bolt and remove the left crank cover. Remove the gasket and the dowel pins.

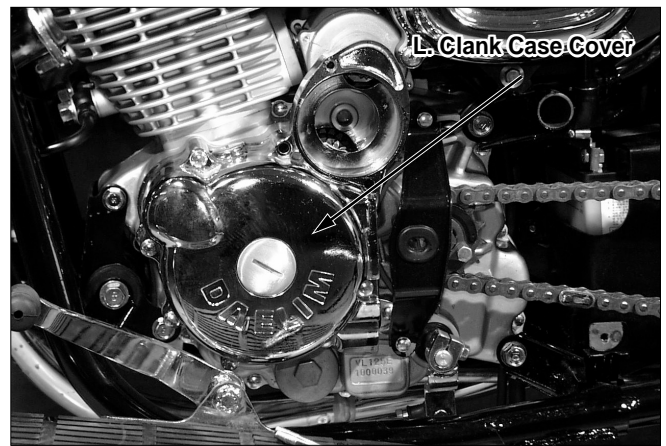

- Remove the starter idle gear shaft and starter idle gear.



- Hold the flywheel rotor with a holder and remove the rotor bolt.  
Tool: Flywheel holder

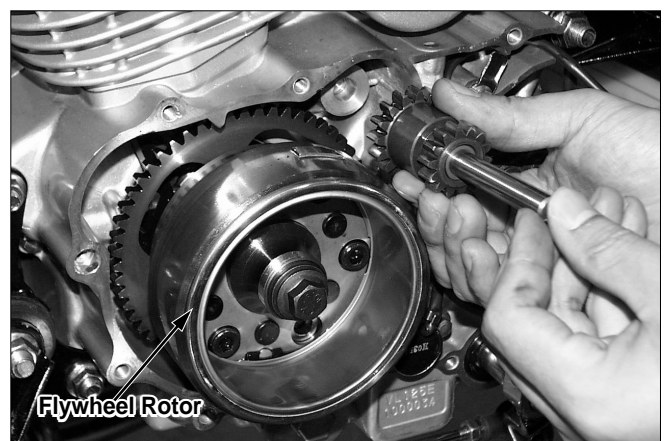



## A.C Generator / Starter Clutch

- After installing the flywheel puller on the rotor, remove the rotor.  
Tool: Flywheel puller

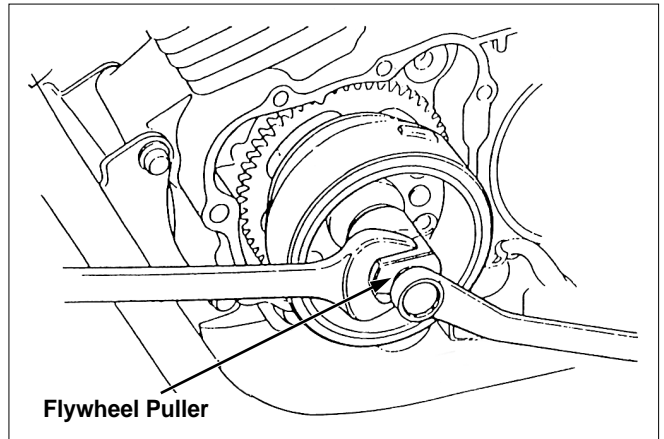

- Remove the woodruff key from the crank shaft.
- Remove the starter driven gear collar.

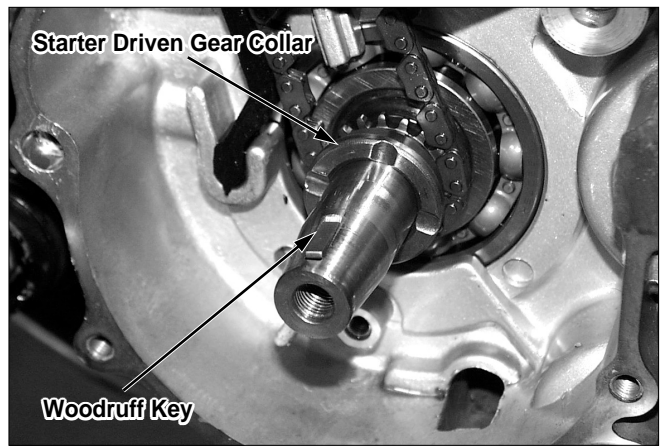

### Stator Removal/Installation

- Loosen the pulse generator mounting screw and remove the pulse generator.

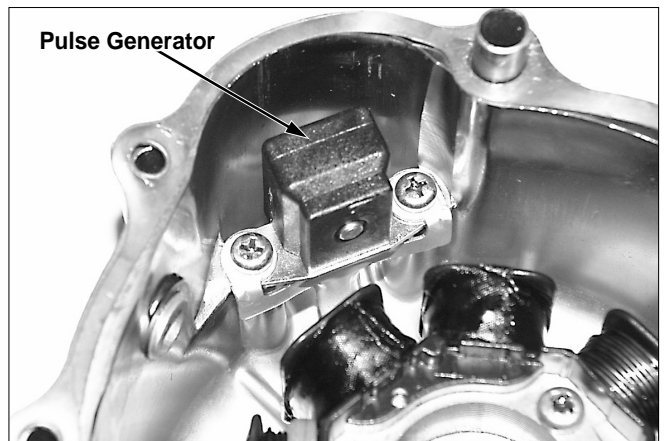

- Loosen the screw and remove the wire guide.
- Remove the stator mounting screw and remove the stator. Assemble and install in the reverse order of disassembly removal.

#### \* NOTE

- Make sure that the grommet is correctly placed on the slot.

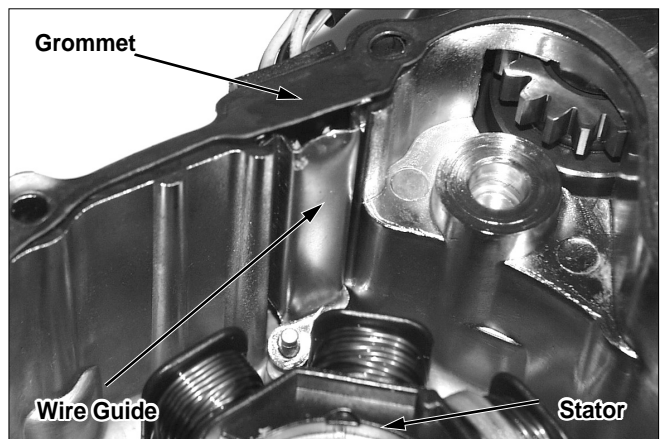

### Starter Idle Gear Inspection

- Inspect the wear and damage of starter Idle gear.
- Measure the gear inside diameter.  
Service Limit : 10.100mm(0.393in)
- Measure the gear shaft inside diameter.  
Service Limit : 9.97mm(0.393in)

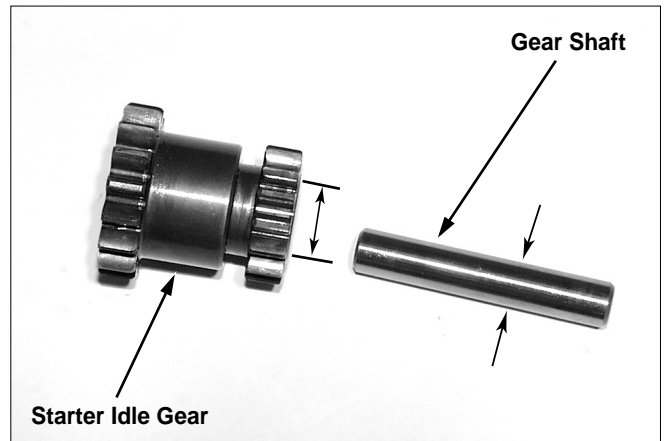

### Reduction Gear Inspection

- Inspect the wear and damage of reduction gear.
- Measure the gear inside diameter.  
Service Limit : 10.100mm(0.393in)
- Measure the gear shaft outside diameter.  
Service Limit : 9.97mm(0.393in)

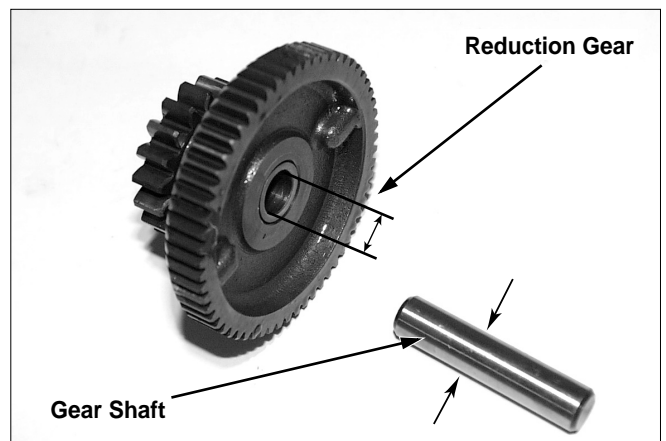

### Assembly

- Install the starter driven gear collar.
- Clean the taper part of crank shaft and remove the dust. If installing the rotor with dust in taper part, the key will be damaged. Because the contacted area of taper will be small and it will occur the stress in the woodruff key.
- Install the woodruff key into the crank shaft key groove.
- Install the rotor into the crank shaft aligning the key.

#### \*NOTE

- After checking whether inside magnet of rotor is attached by the bolts and nuts, install them. If installing the rotor with the foreign material, the starter coil is damaged.
- Install the rotor bolt temporarily. After fixing the flywheel with a holder, tighten the rotor bolt.  
Torque : 5.5kgf-m(55N.m)  
Tool: Flywheel Holder

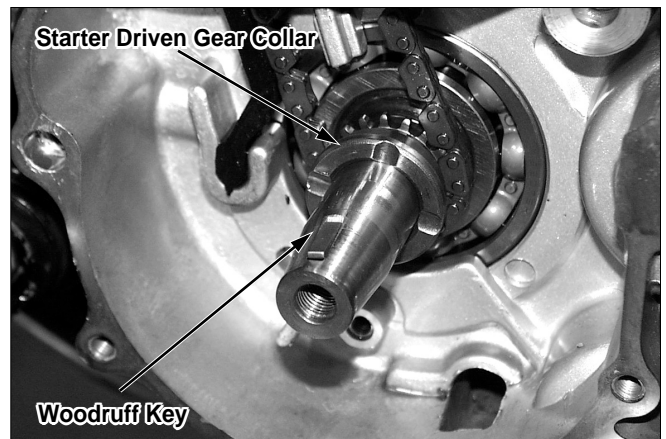

## A.C Generator / Starter Clutch

---

- Install the starter idle gear and shaft.

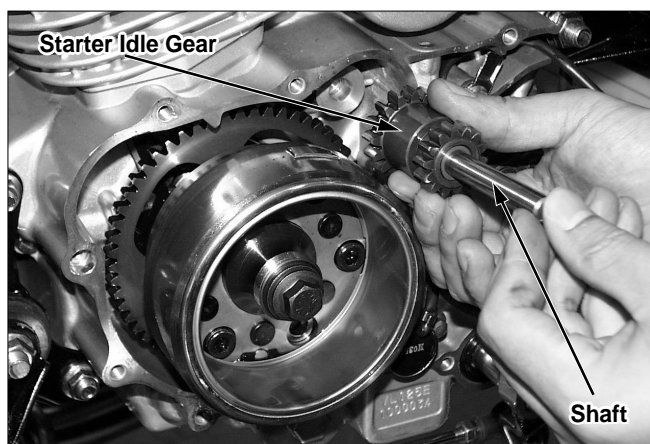

- Install the new gasket and dowel pin.
- Install the l. crankcase cover and tighten the bolt.  
Torque : 1.1kgf-m(11N.m)



- Install the starter gear and shaft.

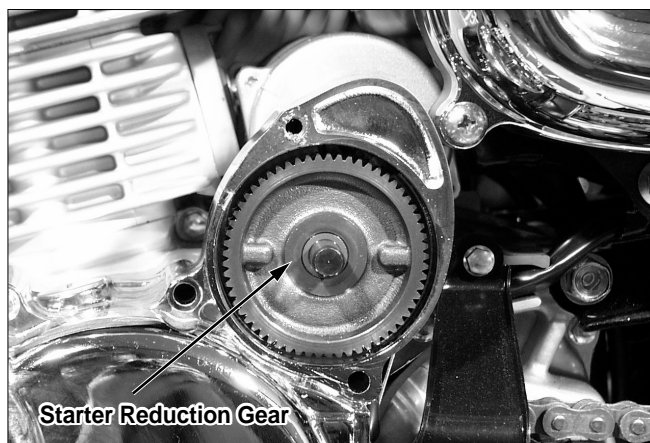

- Install the new o-ring.



- Connect the AC generator wire and gear position light switch wire coupler, and install the wire clamp.

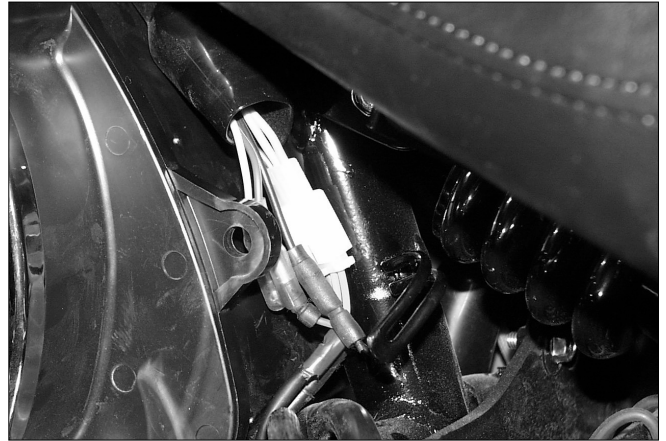

- Install the L. Lower cover and gear change pedal bolt.
- Tighten the gear change pedal bolt.



## Starter Clutch

- Remove the flywheel(⇒ 7-4)
- If the starter driven gear turns to the right when pressing the flywheel as shown, it is in good condition.

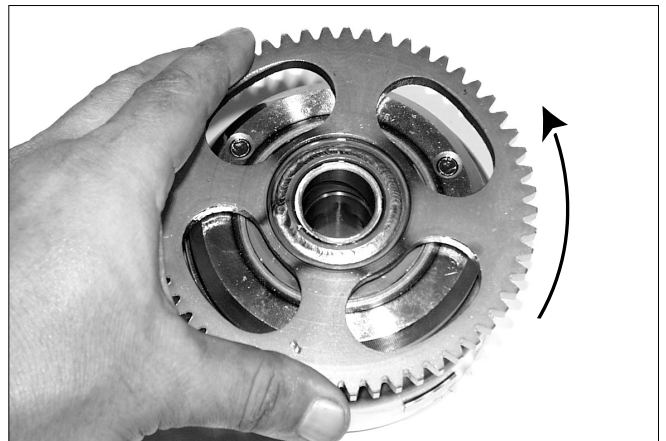

## Disassembly

- Remove the three socket bolts, and remove the one way clutch from the flywheel.



## A.C Generator / Starter Clutch

- Check the starter driven gear for damage and wear.
- Measure the driven gear I.D. and O.D.  
Service Limit:  
O.D. : 42.180mm(1.658in)  
I.D. : 22.100mm(0.870in)

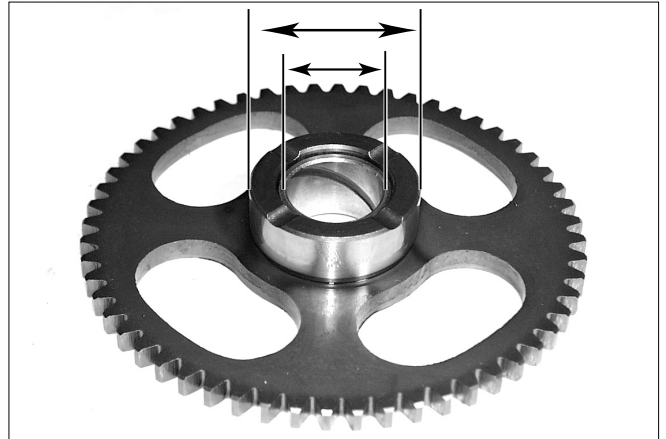

### Assembly

- Inspect the one way clutch for wear and damage.
- Install the way clutch fringe onto the clutch outer.
- After coating the socket bolt with the nut locking bond, install it.  
Torque : 3.2kgf-m(32N.m)

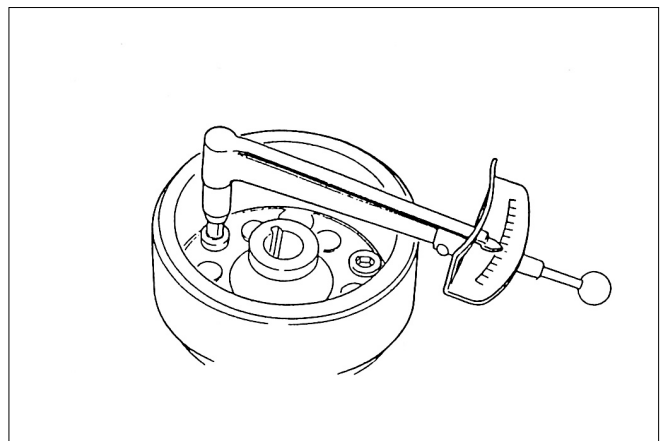
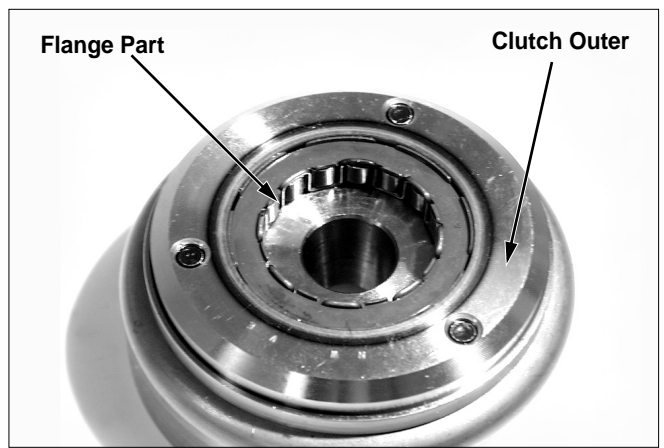



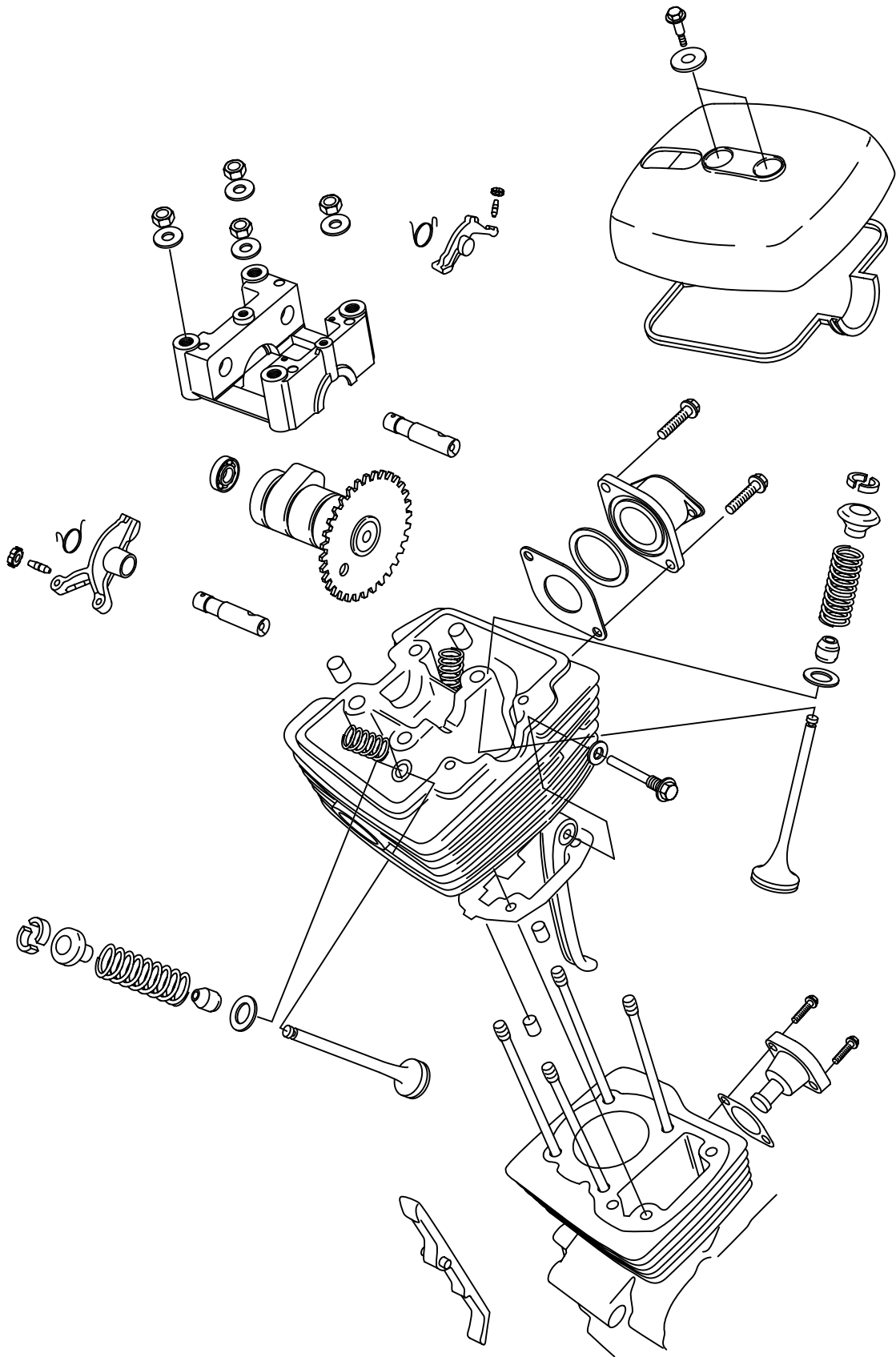

## 8. Cylinder Head / Valve

Service Information .....8-1	Valve Guide Replacement .....8-8
Troubleshooting .....8-2	Valve Seat Inspection .....8-9
Camshaft Removal .....8-3	Cylinder Head Assembly .....8-11
Cylinder head Removal .....8-5	Cylinder Head Assembly .....8-13
Cylinder Head Disassembly .....8-6	Cylinder Heand Installation .....8-13

### Service Information

#### General

- Rocker arm and cam shaft can be serviced with the engine installed in the frame. To service the cylinder heads, the engine must be removed from the frame.
- Cam shaft lubrication oil is fed through an oil pipe. Be sure that the oil pipes and orifice are not clogged before installing the cylinder head.

#### Specifications

Unit:mm(in)

Item			Standard	Service Limit
Rocker Arm	Rocker Arm I.D		12.016~12.034(0.4731~0.4738)	12.060(0.4748)
	Rocker Arm O.D		11.982~12.000(0.4717~0.4724)	11.950(0.4505)
Cam Shaft	Cam Height	IN.	37.640~37.800(1.4819~1.4881)	37.420(1.4732)
		EX.	37.520~37.680(1.4772~1.4835)	37.300(1.4685)
Valves	Valve Spring Free Length	IN., EX.	41.65(1.640)	40.0(1.57)
	Valve Stem O.D	IN.	4.975~4.990(0.1959~0.1965)	4.925(0.1939)
		EX.	4.995~4.970(0.1951~0.1957)	4.905(0.1931)
	Valve Guide I.D	IN., EX.	5.000~5.012(0.1969~0.1973)	5.03(0.198)
	Stem to Guide Clearance	IN.	0.010~0.037(0.0004~0.0015)	0.08(0.003)
		EX.	0.030~0.057(0.0012~0.0022)	0.10(0.004)
Valve Seat Width		0.7~0.9(0.028~0.035)	1.3(0.051)	



## Cylinder Head / Valve

---

### Torque Values

Cam Chain Tensioner Pivot Bolt	1.1kgf-m(11N.m)
Spark Plug	1.1kgf-m(11N.m)-Apply engine oil
Camshaft Holder 8mm nut	2.0kgf-m(20N.m)-Apply engine oil
Cam Chain Tensioner Mounting Bolt	1.2kgf-m(12N.m)
Cam Chain Tensioner Sealing Screw	0.4kgf-m(4N.m)
Cylinder Head Cover Bolt	1.0kgf-m(10N.m)
Crank Shaft Hole Cap	0.8kgf-m(8N.m)
Timing Hole Cap	0.6kgf-m(6N.m)

### Tools

Special	Common
Dowel Pin Puller Set	Valve Spring Compressor
Sliding Shaft	Valve Seat Cutter
Sliding Weight	Seat Cutter IN 35°(23mm)
Valve Guide Reamer	EX 35°(20mm)
Valve Guide Driver	IN 45°(24.5mm)
	EX 45°(24.5mm)
	IN 60°(22mm)
	EX 60°(22mm)
	Cutter Holder 5mm

## Troubleshooting

- Cylinder head operation problem can be diagnosed by a compression test, or by tracing noises to the top end with a sounding rod or stethoscope.

### low compression

- Valves
  - Improper valve clearance adjustment
  - Broken or damaged valve spring
  - Incorrect valve timing
  - Faulty valve seat adherence
- Cylinder head
  - Leaking or damaged head gasket
  - Warped or cracked cylinder head
- Cylinder and piston (Refer to section 9)

### Excessive smoke from muffler

- Worn valve guide or valve stem
- Damaged valve stem seal
- Worn and damaged piston ring

### Incorrect idle speed

- Compression is too low

### Compression is too high

- Excessive carbon build-up on piston or combustion chamber

### Excessive noise

- Incorrect valve clearance adjustment
- Sticking valve or broken valve spring
- Worn or damaged camshaft
- Worn or damaged rocker arm and rocker arm shaft
- Worn or damaged cam chain
- Worn or damaged cam chain tensioner
- Damaged cylinder head gasket
- Improper spark plug installation

## Camshaft Removal

- Remove the fuel tank(⇒ 4-3)
- Remove the cylinder head cover bolts and cover.
  
- Remove the timing hole cap and crank shaft hole cap out of the left crankcase cover.
- Rotate the crankshaft clockwise, place the flywheel “T” mark on the left crankcase cover index mark.
- Make sure that the piston is placed on the compression groove. (All the cam lobes of the camshaft should face down.)
- Rotate the crankshaft clockwise on turn(360°) and place the “T” mark on the index mark.
  
- Loosen the sealing screw of the cam chain tensioner. Remove the tensioner mounting bolt and tensioner.
  
- Remove the camshaft holder 8mm nuts.
- Remove the camshaft holder from the cylinder.

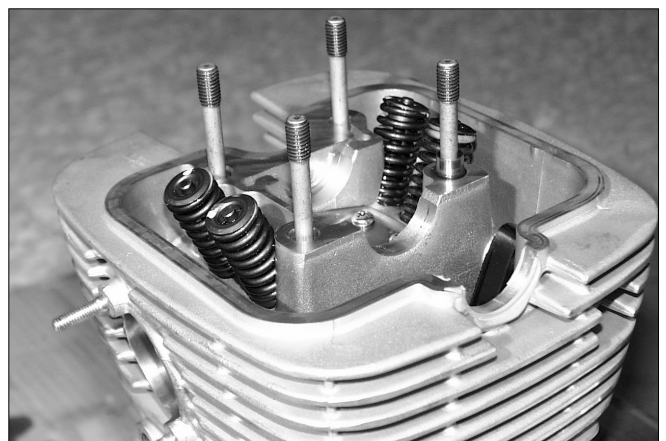
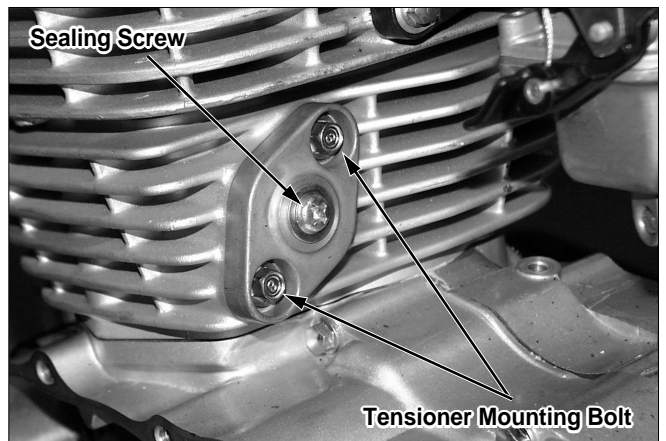

## Cylinder Head / Valve

- Remove the cam chain from camshaft.
- In order to separate the cam chain from the crank case, bind it with the thread or a string.
- Remove the camshaft.

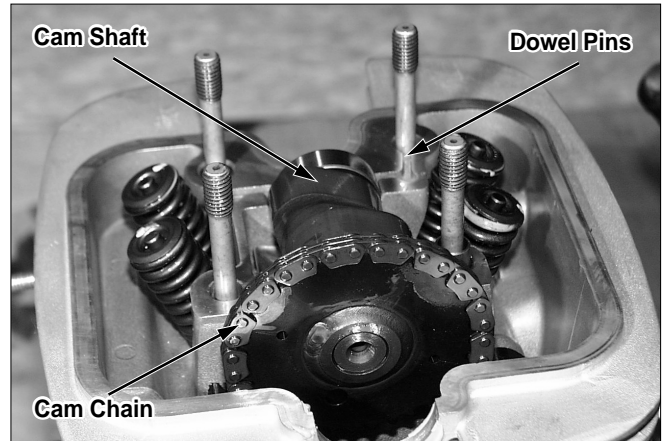

### Camshaft Holder Disassembly

- Remove the end of the rocker arm spring from the dowel pins.

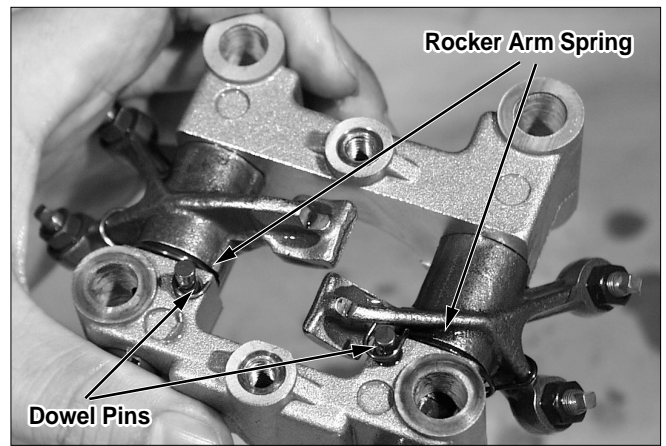

- Remove the dowel pins from the Camshaft holder using the following

Tools:

- Dowel pin puller set
- Sliding shaft
- Sliding weight

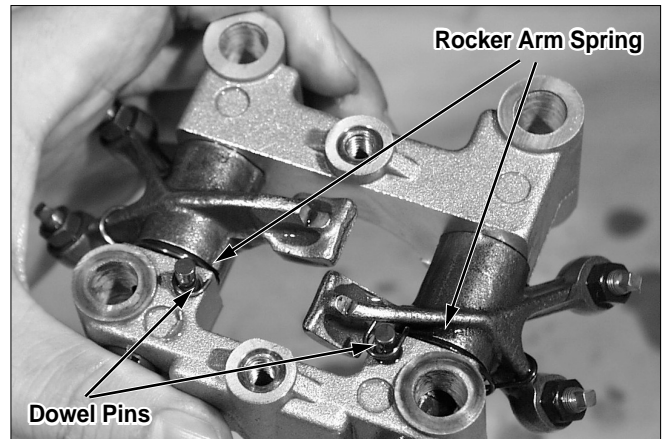

- Put the 6mm bolt into the rocker arm shaft, remove the rocker arm shaft, pulling the bolt.
- Remove the rocker arm and rocker arm spring
- Remove the other rocker arm shaft, rocker arm, and rocker arm spring following the same order.



### Inspection

- Inspect the rocker arm and rocker arm shaft for wear and damage.
- Measure the rocker arm I.D.  
Service Limit : 12.060mm(0.4748in)
- Measure the rocker arm O.D.  
Service Limit : 11.950mm(0.4505in)

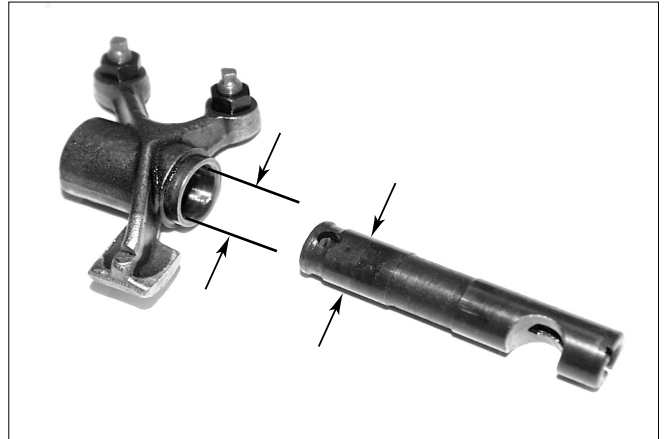

- Inspect the cam lobe of the camshaft for wear and damage.
- Measure the height of the cam lobe.  
Service Limit:IN) 37.420mm(1.4732in)  
EX) 37.300mm(1.4685in)



- Turn the outer race of each bearing with your finger. The bearing should turn smoothly and quietly.
- Check the bearing for damage.



### Cylinder Head Removal

- Remove the engine from the frame (⇒ 5)
- Remove the camshaft.
- Remove cylinder head from the cylinder.



## Cylinder Head / Valve

- Remove the gasket, dowel pins, and cam chain guide from the cylinder.



## Cylinder Head Disassembly

- Loosen the pivot bolt and remove the cam chain tensioner.
- Remove the carburetor insulator.
- Remove the spark plug from the cylinder head.
- Remove the spark plug cover from the cylinder head.

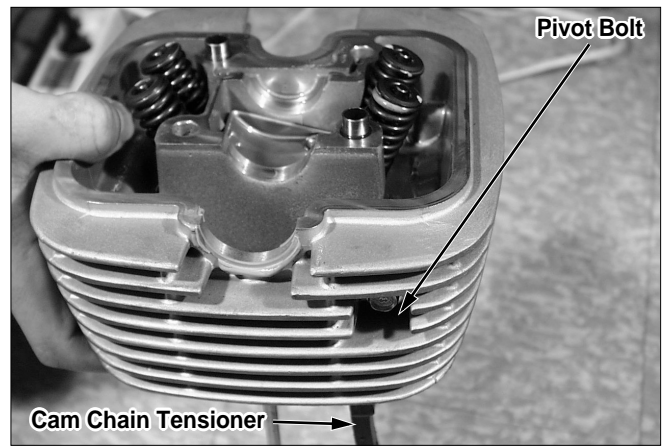

- Remove the valve spring, valve cotter, retainer, spring, and valve.  
Tool: Valve spring compressor

### ⚠ CAUTION

- To prevent the loss of tension, do not compress the valve springs more than necessary to remove the cotters.

### \* NOTE

- Mark all parts during disassembly so they can be placed back in their original locations.

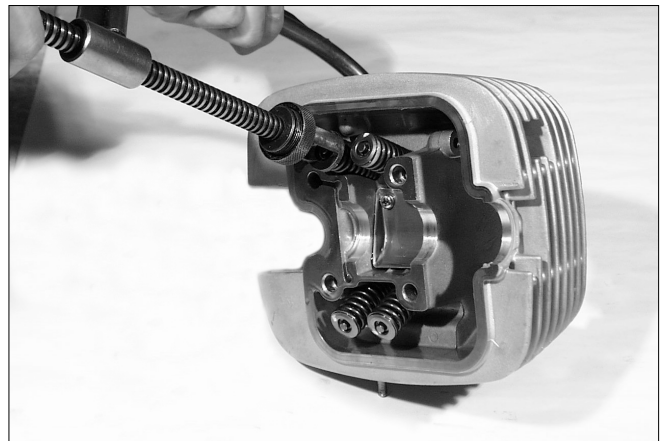

- Remove the valve stem seals and valve spring seals, remove the carbon deposits from the combustion chamber.

## Cylinder Head

- Clean off the head gasket surface.

### ⚠ CAUTION

- Avoid damaging the gasket surfaces.

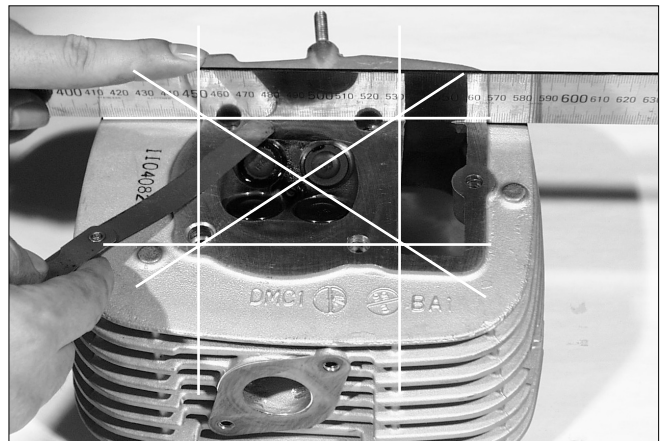

- Inspect the spark plug assembly hole and the crack of near valve seat. Check for the warp of the cylinder head with a square and filler gauge.

Service Limit : 0.1mm(0.004in)

### Valve Spring

- Measure the free field of valve spring.
- Service Limit : 40.0mm(1.57in)

#### ⚠CAUTION

- If any valve spring is shorter than the service limit, it must be replaced as a set.

### Valve Step-To-Guide Clearance

- Inspect the bent, clogging, damaging, and step wear of valve.
- Check the valve step with valve guide.
- Measure the valve step outside diameter and record it.

Service Limit : IN) 4.925mm(0.1939in)  
EX) 4.905mm(0.1931in)

- After inserting the valve guide reamer to the combustion chamber, remove the carbon deposits.

#### ⚠CAUTION

- The incoming and outgoing of reamer should be performed by turning the reamer to the right. If the entrance of reamer without turning or turning to the left, the guide inside will be damaged.

Tool: Valve guide reamer

- Measure the valve guide inside diameter and record it.

Service Limit : 5.03mm(0.198 in)

- Calculate the valve step and guide clearance.

Service Limit : IN) 0.08mm (0.003 in)  
EX) 0.10mm (0.004 in)

- Measure the inside diameter of new valve guide, and must be replaced with the new valve if the clearance is not in service limit.

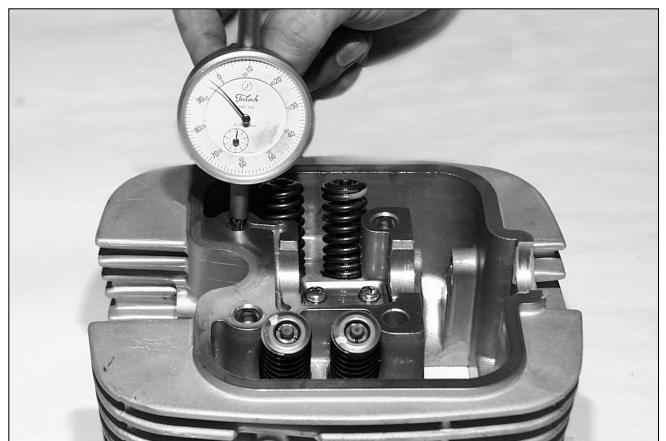
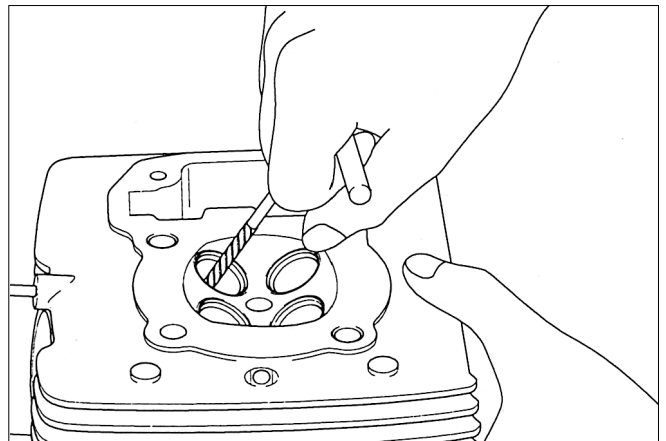
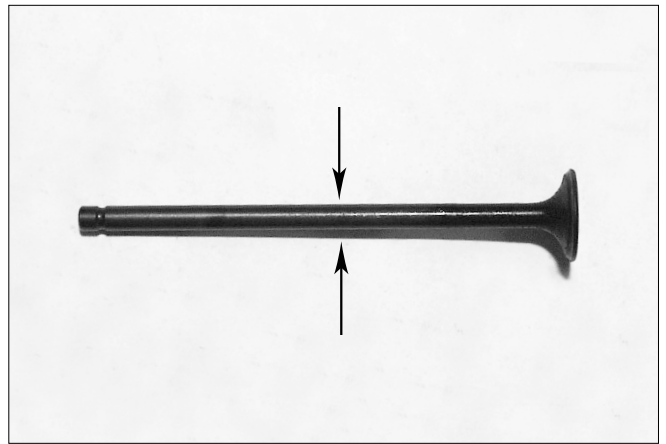
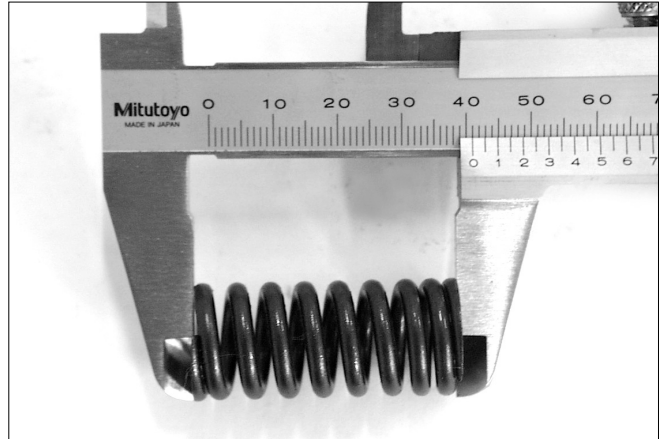

## Valve Guide Replacement

**⚠ CAUTION**

- When replacing the valve guide, valve seat must be amended.
- Heat the cylinder head equally to 130-140°C.
- Avoid heating over 150°C

**⚠ CAUTION**

- Avoid performing the unskilled work. It is caused a burn.
- When heating the cylinder Head, do not heat it sectionally using a gas burner. It is caused the twist of cylinder Head.

- Hold the cylinder head, and remove the valve guide from the combustion chamber using valve guide driver.

Tool : Valve guide driver

**⚠ CAUTION**

- Avoid the cylinder head from damaging.
- Install the new o-ring into the new valve guide.
- Insert the valve guide in the top of the cylinder head.  
Tool: Valve guide driver.
- After inserting the valve guide, install the valve guide reamer in the combustion chamber of the cylinder head and trim the valve guide.

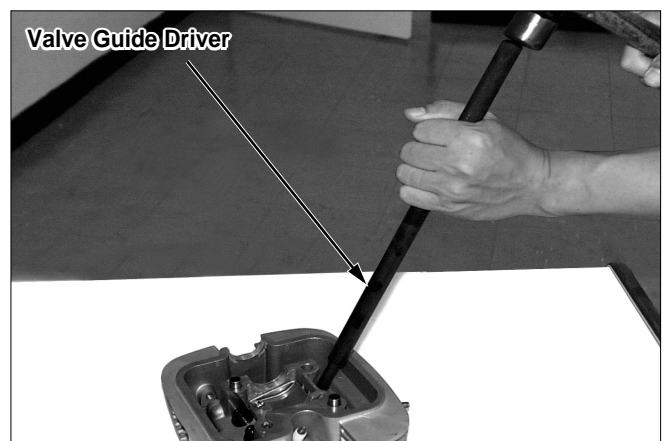
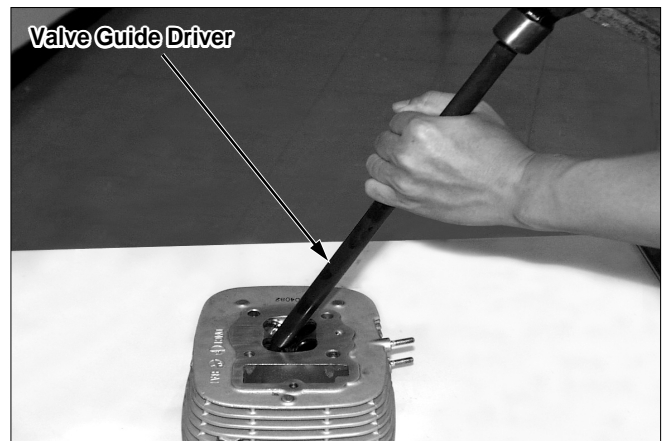

**⚠CAUTION**

- Trim the reamer not to lean. If cutting the reamer by leaning, the valve hole is inclined, the step seal is leaked, and the around of valve seat is enlarged. So the around of seat is not amended.

- The entrance of reamer is always performed by turning the reamer to the right. If not, the guide inside is damaged.

Tool: Valve guide reamer

- Clean the cylinder head and remove the foreign substances.
- Check the around of valve seat and amend them.

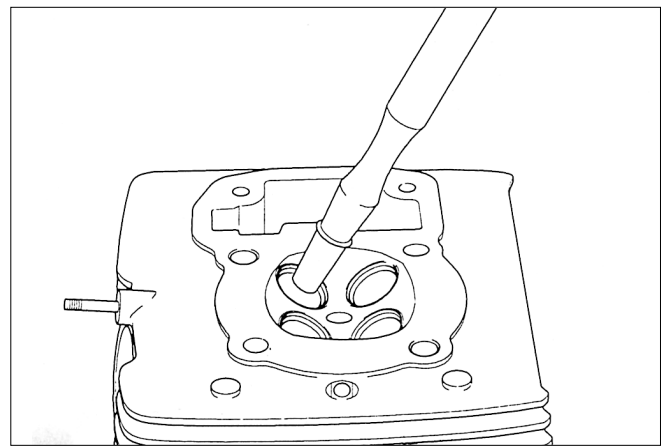
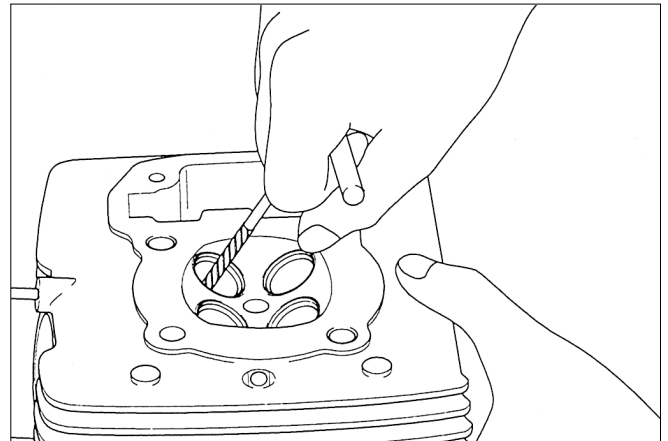

### Valve Seat Inspection

- Remove the carbon deposits of valve.
- Coat the valve of cylinder head with the ink thinly.
- Trim valve guide reamer using a valve guide reamer without turning the valve, and align the position exactly.

- Take off the valve, inspect the opposite side of the seat with the ink attachment of valve pace side.
- If the valve seat is damaged, amend the valve seat.
- If the valve is inclined, inspect the valve guide-to-step gap and replace valve guide if necessary.

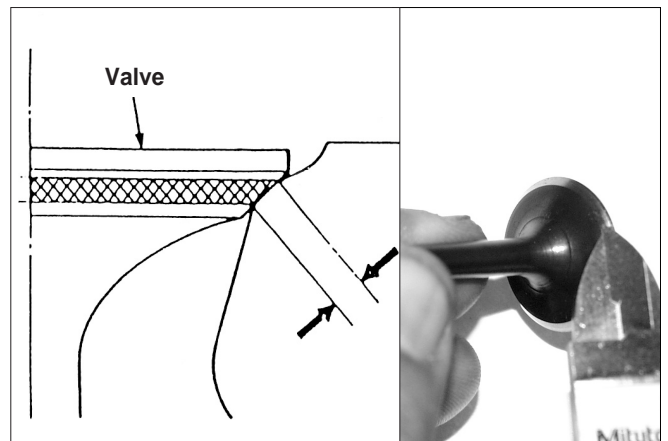

**⚠CAUTION**

- It is impossible to amend the valve. If the valve pace clogging, wear and connection are bad, the valve must be replaced.

- Measure the valve seat width.  
Standard Value : 0.7~0.9(0.028~0.035)  
Service Limit : 1.3mm(0.05in)

### Valve Seat Cutter

- Amend the worn valve seat using a valve seat cutter and a grinder.

**⚠CAUTION**

- Perform them according to the instruction manual.

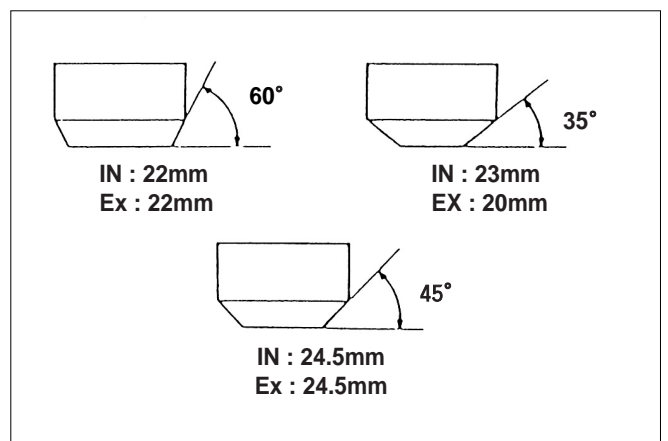



### Valve Seat Amendment

- If the Seat part is damaged or rough, cut them using 45° cutter.

#### ⚠ CAUTION

- After replacing the valve guide, cut the seat part.

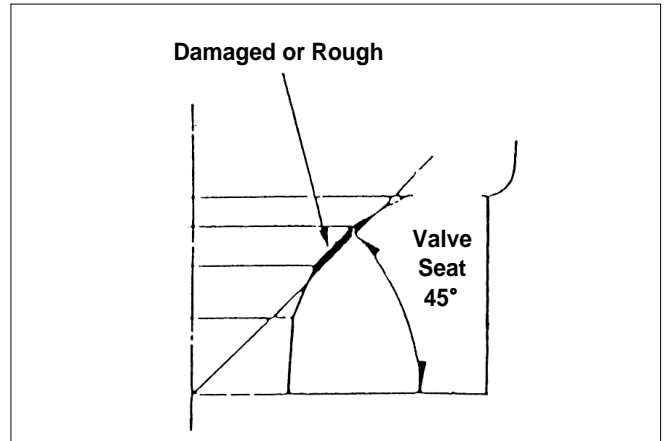

- Amend the flat using a 35° cutter side by side.

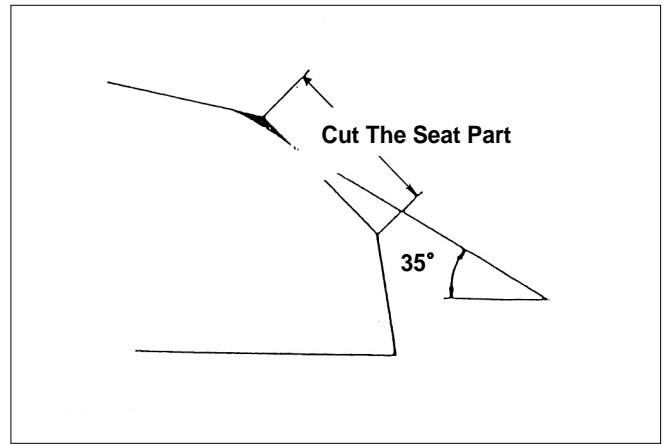

- Amend the inside using a 60° cutter side by side.

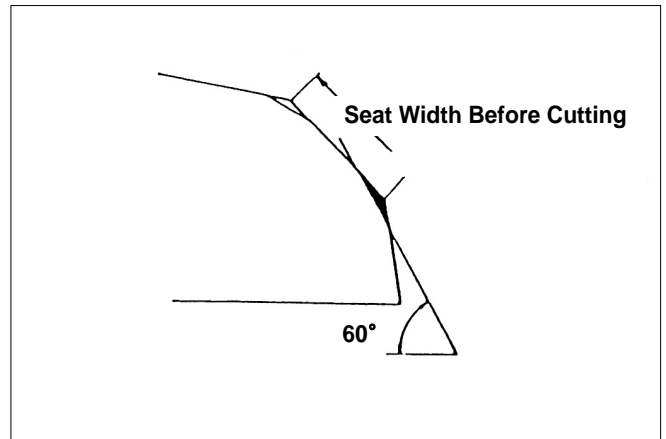

- Amend the seat part with a standard width using a 45° cutter.

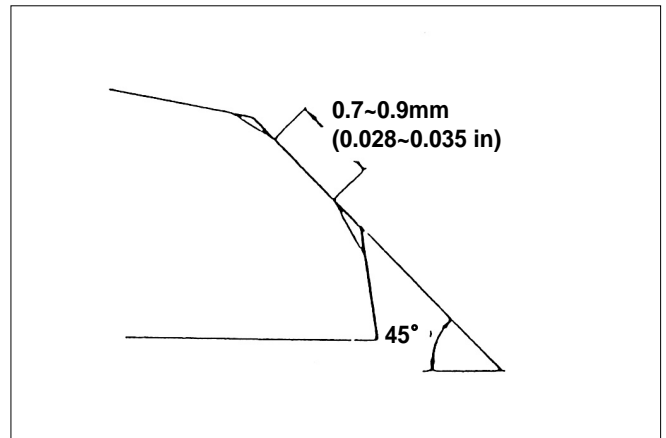

- Coat the valve seat with the compound.
- Use the valve guide reamer without turning the Valve, check the attached state by hitting against lightly.
- If the position of contacting side is high, cut it using a 35° cutter, and then cut it using a 45° cutter according to the standard width.

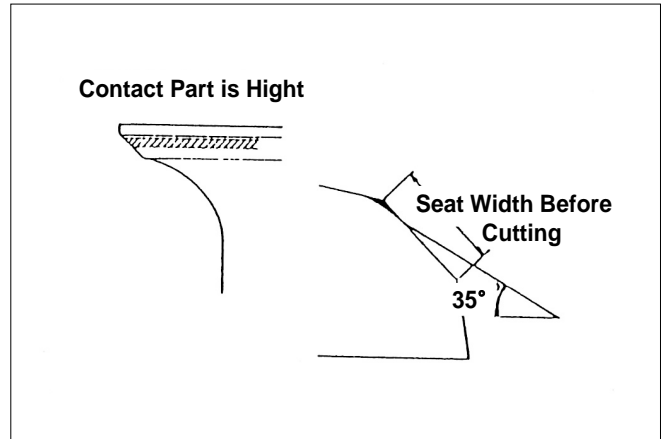

- If the position of contacting side is low, cut it using a 60° cutter, and then cuts by 45° cutter according to the standard width.

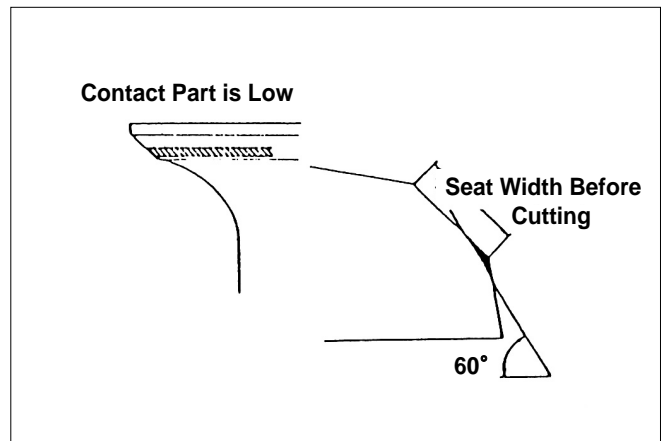

- After amending, coat the valve seat with a compound and align the valve using a valve guide reamer.

**CAUTION**

- If it is turned by pressing the valve to seat strongly when aligning the valve, it is damaged. Therefore, align it by trimming lightly.
- If aligning the valve in same position, it is caused that seat is worn partly. Therefore align valve by turning.
- Avoid putting compound in the gap of step and guide while aligning the Valve.

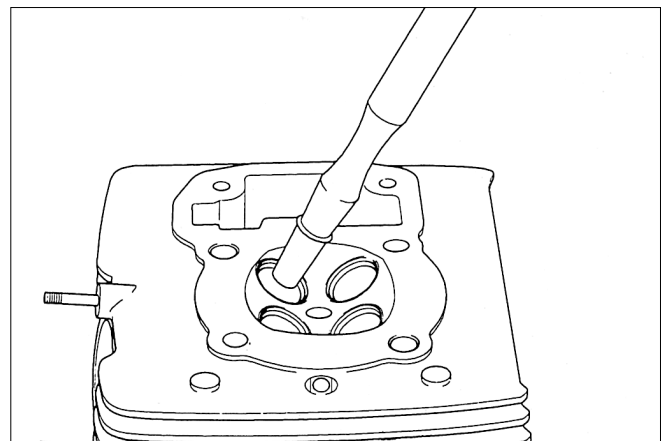

## Cylinder Head Assembly

- Install the valve spring seat and a new stem seal.
- Lubricate each valve stem with molybdenum disulfide grease and insert the valve into the valve guide. To avoid damage to the stem seal, turn the valve slowly when inserting.
- Check the valve for freedom of up-down movement.

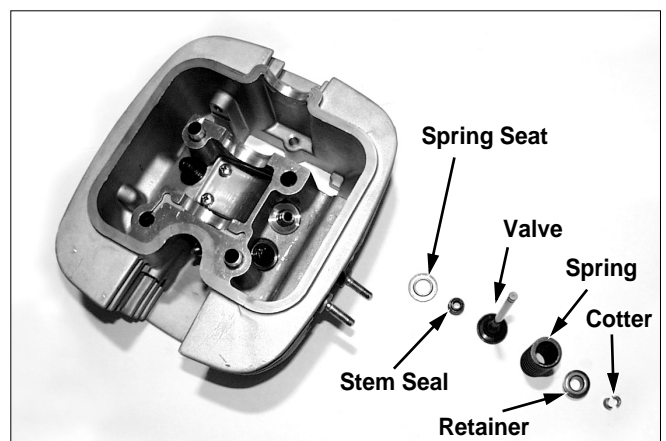

## Cylinder Head / Valve

- Install the valve springs. The springs tightly would coils should face toward the cylinder head.

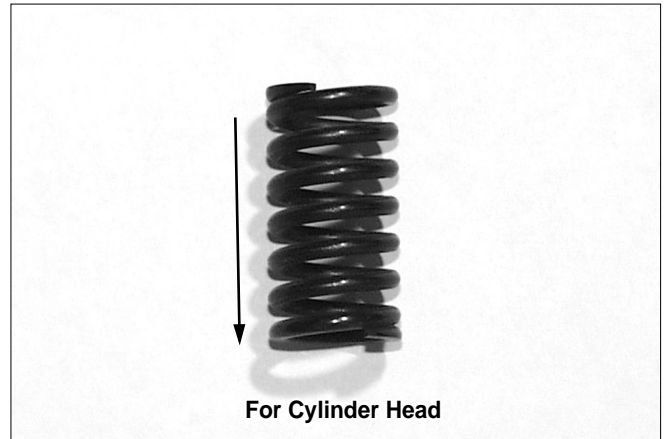

- Install the springs retainer.
- Compress the valve spring and install the valve cotters.

**\* NOTE**

- To prevent the loss of tension, do not compress the valve springs more than necessary to install the valve cotters.

Tool: Valve spring compressor

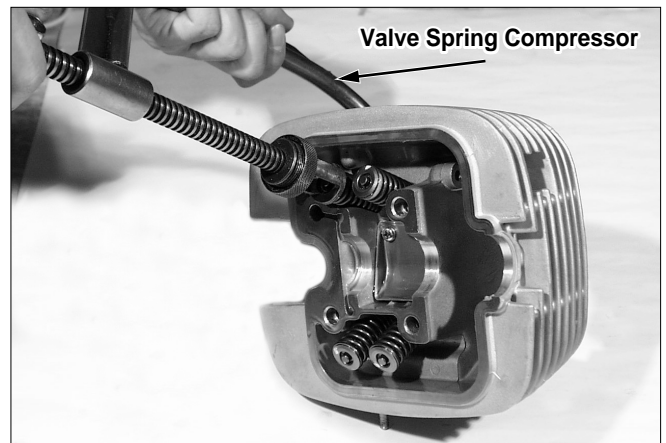

- Tap the valve stems gently two or three times with a soft hammer to firmly seat the cotters.

**\* NOTE**

- Be careful not to damage the valve.

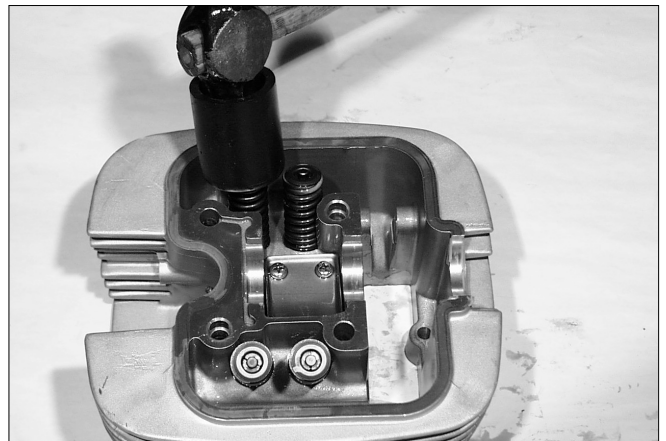

- Coat a new O-ring with engine oil and install it into the carburetor insulator groove.
- Install the carburetor insulator with the mounting bolt tightly.

- Install the cam chain tensioner and tighten the pivot bolt.

Torque : 1.1kgf-m(11N.m)

- Install the spark plug.

Torque : 1.1kgf-m(11N.m)

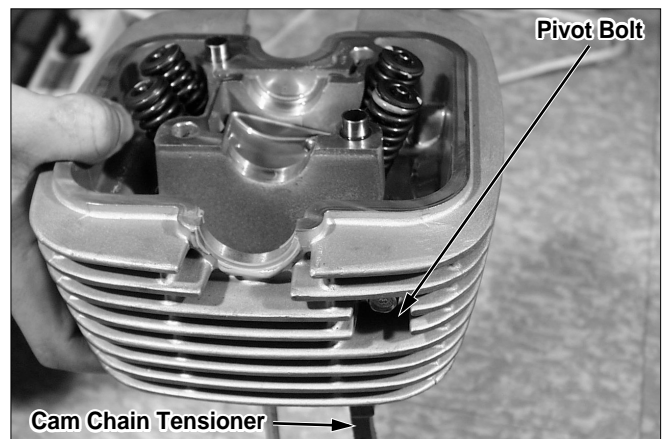

## Cylinder Head Installation

- Clean the cylinder head surface of any gasket materials.
- Install the cam chain guide into the cylinder.
- Install the dowel pins and a new gasket.

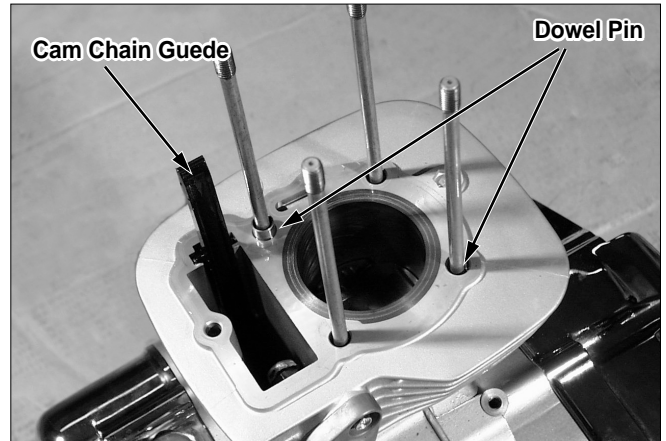

- Install the cylinder head.
- Install the cam shaft.
- Install the engine into the frame(⇒ 5)

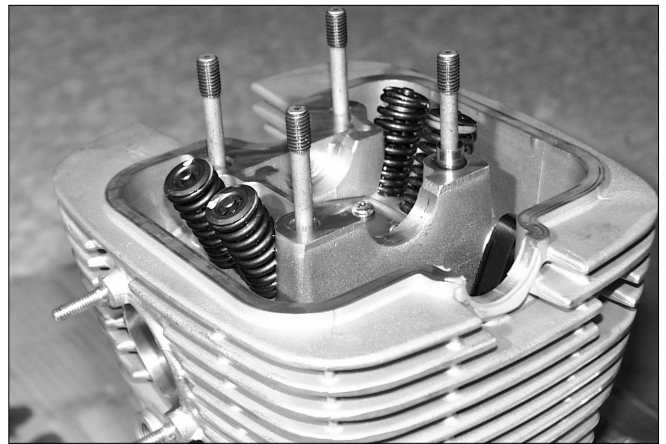

## Camshaft Installation

- Install the rocker arm ring and rocker arm on the camshaft holder.
- Coat the rocker arm shaft with engine oil and install it into the camshaft holder.

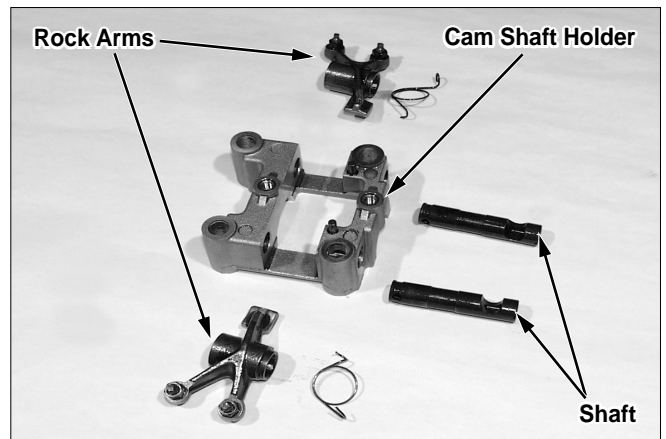

- Rotate the rocker arm shaft with a driver, align the dowel pin hole and bolt hole of the cam shaft holder and rocker arm shaft.

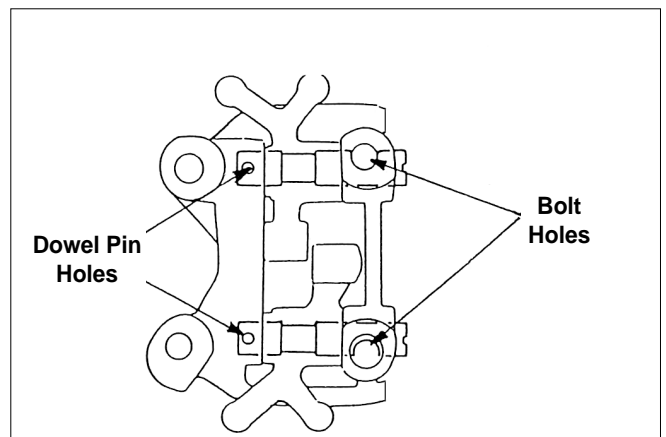

## Cylinder Head / Valve

---

- Insert the dowel pins into the camshaft holder thoroughly. Align the teeth of the rocker arm spring with the dowel pins as shown.

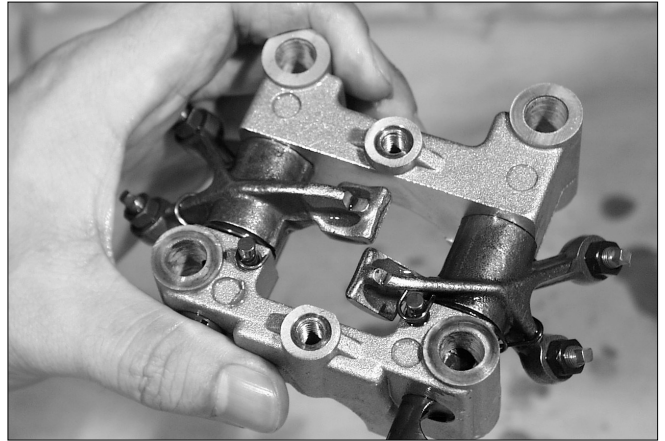

- Check the camshaft ass'y for wear or damage, and Install the Cylinder head
- Install the cam chain on the cam sprocket.



- Rotate the crankshaft to the left slowly, align "T" mark on the flywheel with the index mark on the left crankcase cover.

### \* NOTE

- When turning the crankshaft, make sure that the cam chain does not come off from the crankshaft timing gear.

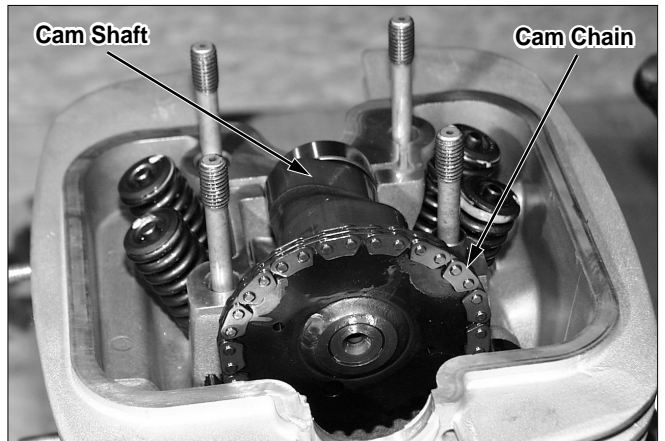

- Coat the camshaft with engine oil, and install the cam lobe on the cylinder head with the cam lobe facing down. With the timing marks on the cam sprocket parallel to the top of the cylinder head, Install the chain and sprocket.
- Install the dowel pins on the cylinder head.
- Install the dowel pin into the cylinder Head.

- Install the dowel pin into the cylinder Head.



- Install the camshaft holder.
- Apply engine oil to the nut part, install and tighten the cam shaft holder nut and bolt in two or three steps as shown  
Torque : 2.0kgf-m(29N.m)

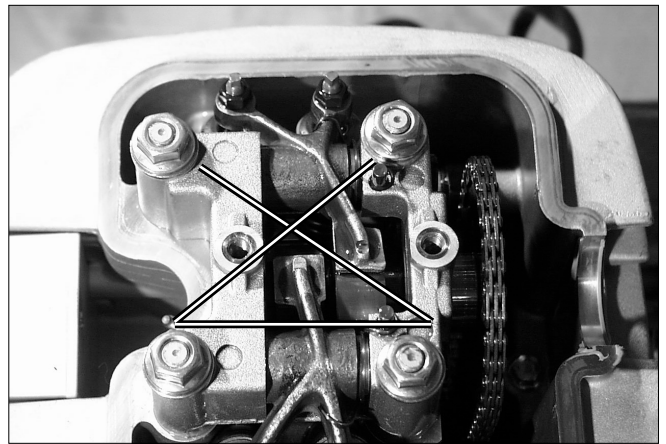

- Remove the sealing screw and washer from the cam chain tensioner lifter. Remove the shaft from the body by turning the tensioner shaft to the right with a small driver.

**CAUTION**

- When dropping the cam chain tensioner lifter, the shaft is proceeded by the spring power.

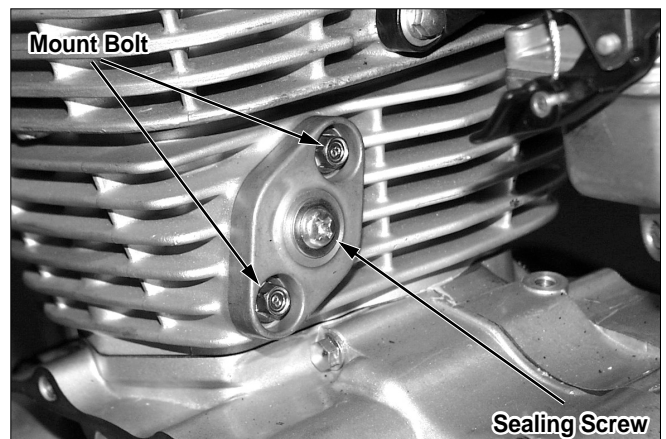

## Cylinder Head / Valve

- Hold the tensioner shaft with the light clip as shown. Install a new gasket into the tensioner lifter, then install the tensioner lifter into the cylinder.
- Install the tensioner mounting bolt.  
Torque: 1.2kgf-m(12N.m)

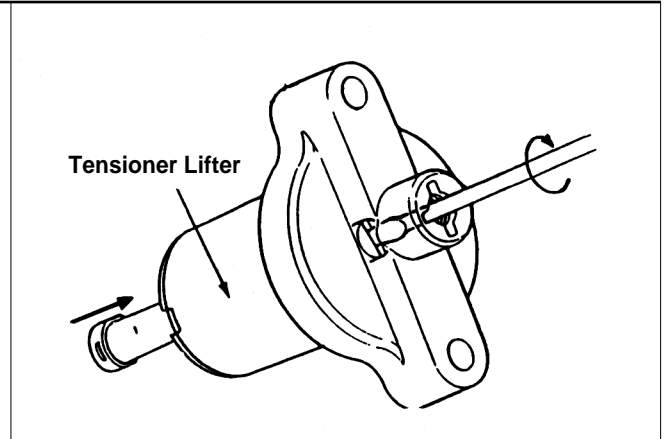

- From the tensioner lifter, remove the clip which holds the tensioner shaft.
- Install the sealing washer and screw on the tensioner lifter.  
Torque: 0.4kgf-m(4N.m)



- Apply clean engine oil to all the operation parts of the cylinder head.
- Adjust the valve clearance(⇔ 3-6)
- Install the crankshaft hole cap and timing hole cap.  
Torque:  
Crank shaft hole cap: 0.8kgf-m(8N.m)  
Timing hole cap: 0.6kgf-m(6N.m)



- Clean oil in the slot part ㊦ of the cylinder head cover.
- Place the gasket on the correct position in the cover.
- Install the cylinder head cover.
- Tighten the cylinder cover bolt.  
Torque: 1.0kgf-m(10N.m)
- Install the fuel tank(⇔ 4-3)







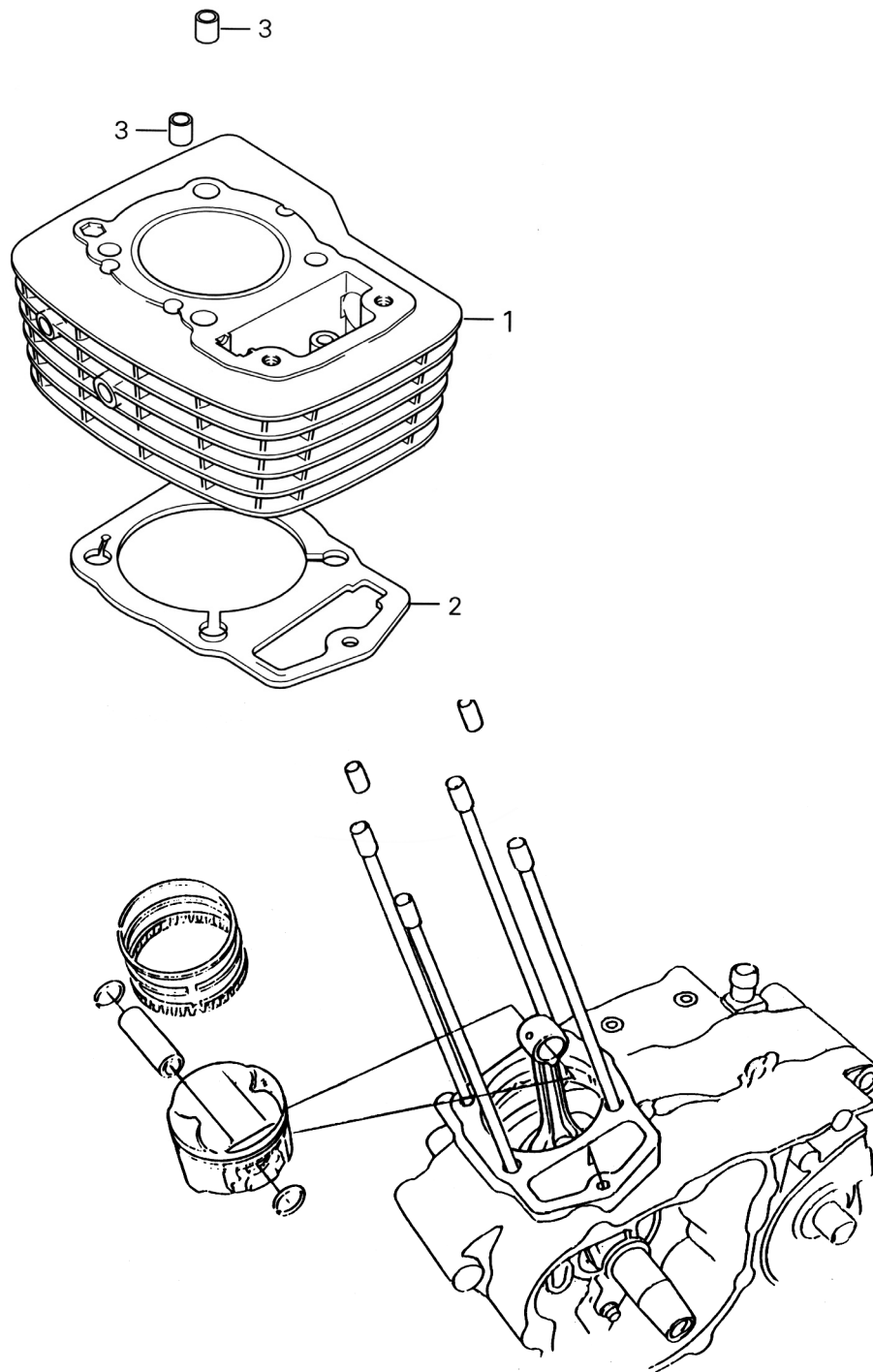

## 9. Cylinder / Piston

<b>Service Information</b> .....	<b>9-1</b>	<b>Piston</b> .....	<b>9-3</b>
<b>Troubleshootint</b> .....	<b>9-1</b>	<b>Piston/Cylinder Installation</b> .....	<b>9-5</b>
<b>Cylinder</b> .....	<b>9-2</b>		

### Service Information

#### Geeneral

- When removing the cylinder, avoid damaging the cylinder joint part with a driver or cooling pin by hitting the cylinder strongly.
- Avoid damaging the inside of the cylinder and piston surface.

#### Specifications

Unit: mm(in)

Item		Standard	Service Unit	
Cylinder	I.D	56.500-56.510(2.2244-2.2248)	56.60(2.228)	
	Outer of round	———	0.1(0.004)	
	Taper	———	0.05(0.002)	
	Warpage	———	0.1(0.004)	
Piston	Piston O.D.	56.470-56.490(2.2232-2.2240)	56.37(2.219)	
	Piston pin hole I.D	15.002-15.008(0.5906-0.5909)	15.04(0.592)	
Piston Pin and Piston Ring	Piston Pin O.D		14.994-15.000(0.5903-0.5906)	
	Piston pin-to-piston clearance		0.002-0.14(0.0001-0.0006)	
	Piston ring-to-groove clearance	top	0.015-0.045(0.0006-0.0018)	0.09(0.004)
		second	0.015-0.045(0.0006-0.0018)	0.09(0.004)
	Piston ring end gap	top/second	0.10-0.25(0.004-0.010)	0.5(0.02)
		oil(side rail)	0.2-0.7(0.01-0.03)	1.1(0.04)
Piston-to-cylinder clearance		0.010-0.040(0.0004-0.0016)	0.15(0.006)	
Connecting rod small end I.D.		15.010-15.028(0.5909-0.5917)	15.06(0.593)	
Connecting rod small end-piston pin clearance		0.010-0.034(0.0004-0.0013)	0.04(0.002)	

### Troubleshooting

#### Lower or uneven compression

- Worn piston
- Worn, damaged piston rings.
- Worn cylinder.

#### Excessive smoke from muffler

- Worn cylinder, piston, and piston rings.
- Improperly installed piston rings.
- Damaged piston, cylinder.

#### Overheating

- Excessive carbon deposits on piston head.

#### Piston noise

- Worn cylinder and piston.
- Worn piston pin, connecting rod small end.
- Damaged piston rings.
- Excessive carbon deposits on piston head.

# Cylinder

### Removal

- Remove the cylinder head(Section 8).
- Remove the cam chain guide from the cylinder.
- Loosen the cylinder mounting bolt, and remove the cylinder.

- Remove the gasket and dowel pins. Remove the gasket from the cylinder.

#### \*NOTE

- Avoid damaging the gasket surface.

### Inspection

- Measure the cylinder inside diameter in 6 places of top, middle, bottom with the piston pin direction and right-angled direction(X-Y direction), and record them. The cylinder inside diameter sets the maximum value.  
Service Limit:56.60mm(2.228in)

- Measure the piston outside diameter.(⇔ 9-4)
- Subtract the piston outside diameter from the cylinder inside diameter, and then get the cylinder-to-piston clearance.  
Service Limit : 0.15mm(0.006in)

- Figure out the taper(balance between the X direction and Y direction) and out of round(inside diameter balance of the top, middle, bottom parts by X or Y direction). Choose the maximum value regardless of any one, and settle the taper and out of round.

Service Limit:Taper) 0.05mm(0.002in)  
Out of round) 0.1mm(0.004in)

- The boring assembly of cylinder measure the outside diameter of the over size piston. And then perform the boring assembly so that the cylinder-to-Piston clearance become the standard value.

Over Size: 0.25mm(0.010in), 0.50mm(0.020in)  
0.75mm(0.030in), 1.00mm(0.039in)

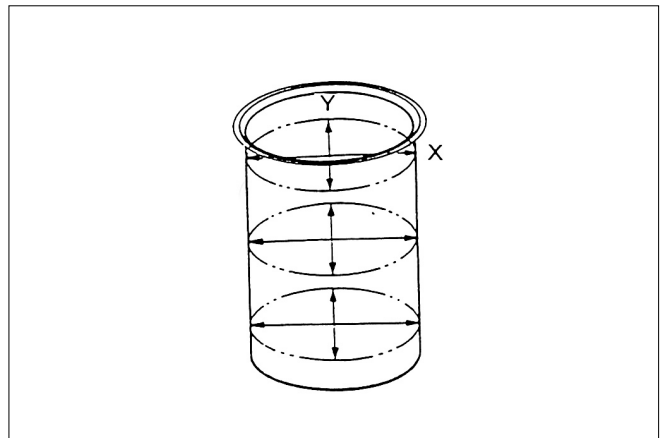
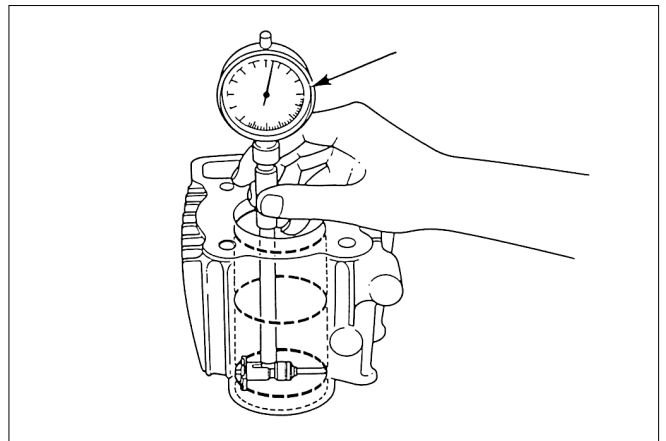
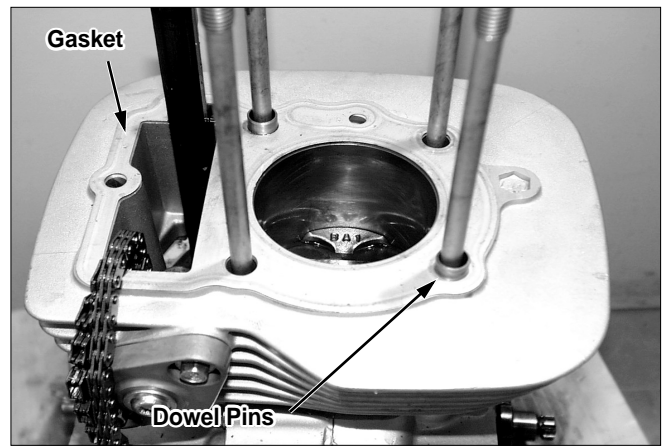

- Inspect the twist of cylinder.  
Service Limit:0.1mm(0.004in)

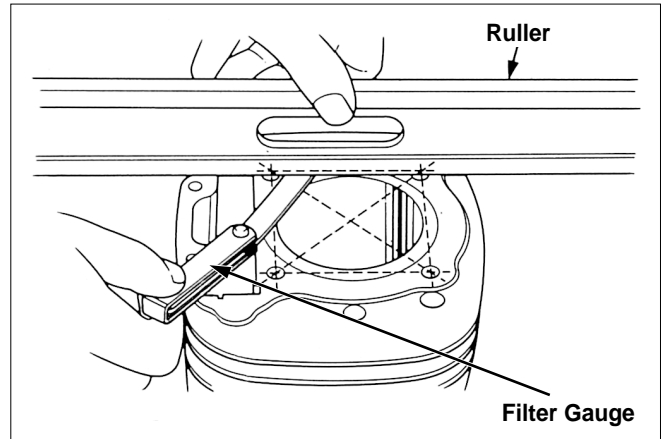

## Piston

### Removal

- Remove the piston pin clips.

**\*NOTE**

- Do not let the clips fall into the crankcase.
- Push the piston pin out and remove the piston.
- Check the piston ring for damage or deterioration.
- Remove the piston rings.

**\*NOTE**

- Be careful when removing the rings.

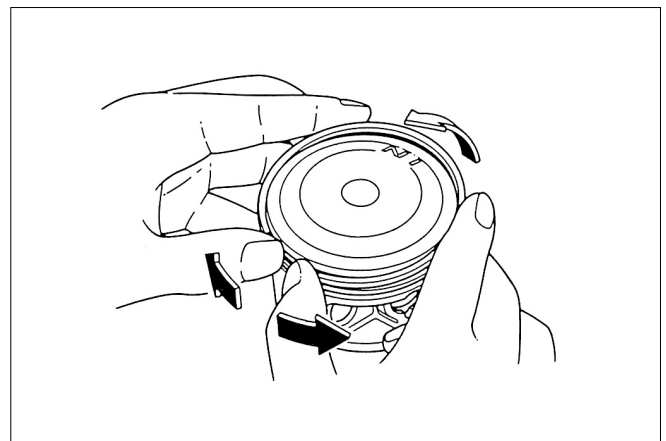
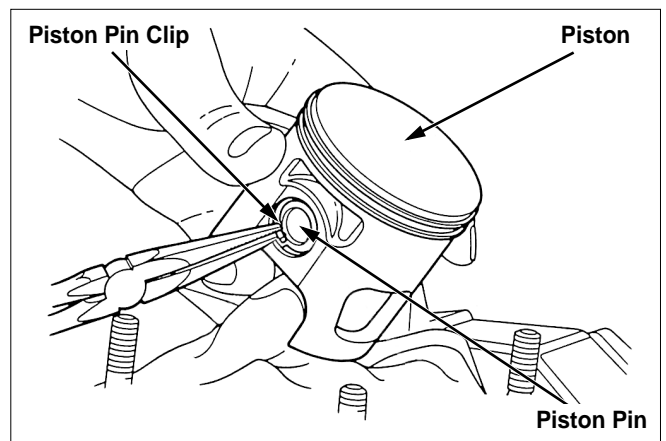

- Measure the piston ring-to-groove clearance.  
Service Limit:  
Top/Second:0.09mm(0.004in)  
Oil:0.09mm(0.004in)
- Inspect the piston for damage and wear.

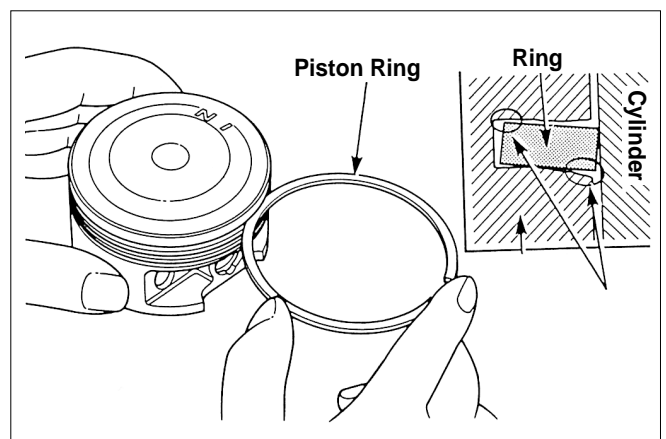

## Cylinder / Piston

- Insert the piston ring into the cylinder inside, and inspect the piston ring clearance.

### \*NOTE

- Insert the piston ring horizontally using a piston head.  
Service Limit:  
Top/Second:0.5mm(0.02in)  
Oil(Side rail):1.1mm(0.04in)

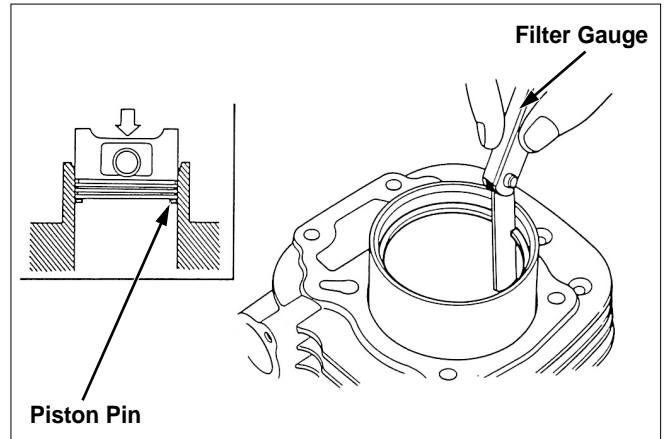

- Measure the piston outside diameter at 10mm position in piston end part facing 90° direction.  
Service Limit:56.37mm(2.219in)

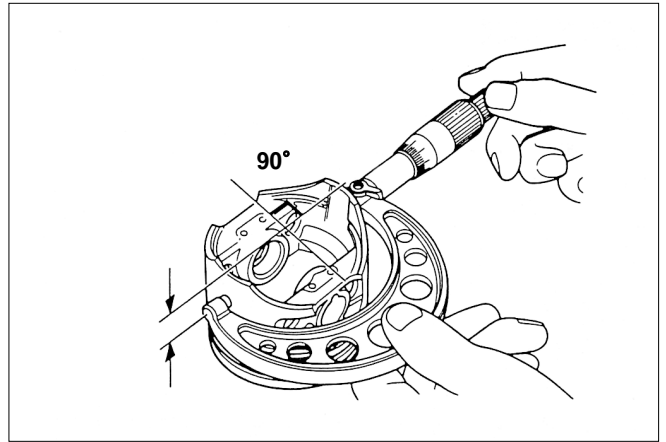

- Measure the piston pin hole inside diameter.  
Service Limit:15.04mm(0.592in)
- Measure the piston pin outside diameter.  
Service Limit:14.96mm(0.589in)
- Figure out the piston-to-piston pin clearance.  
Service Limit:0.02mm(0.001in)

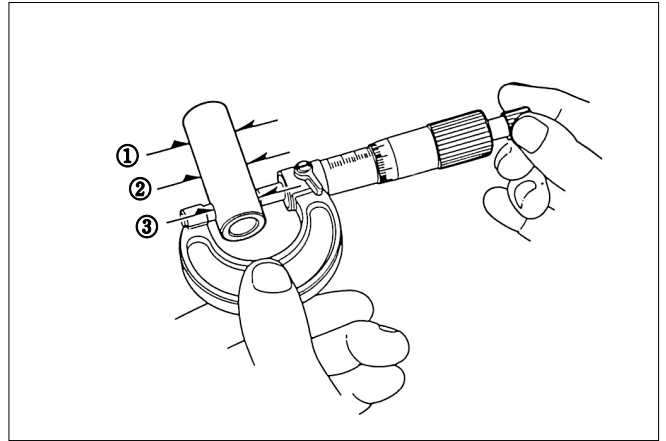

- Measure the connecting rod small end inside diameter.  
Service Limit:15.06mm(0.593in)
- Figure out the connection rod small end inside diameter-to-piston pin clearance.  
Service Limit:0.04mm(0.002in)

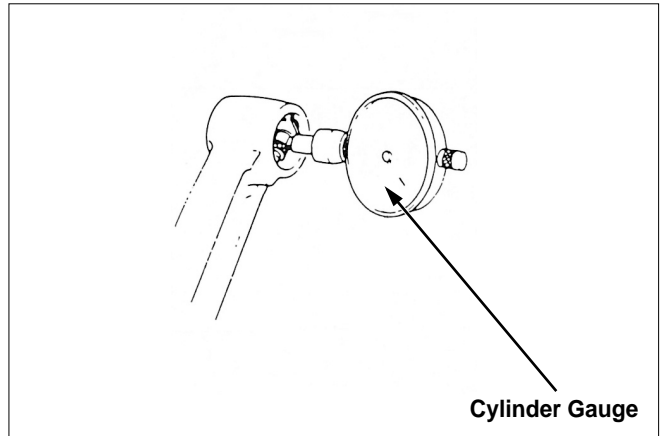

## Piston/Cylinder Installation

### Piston Ring Installation

- Clean the piston domes, ring lands and skirts and install the piston ring.

#### \*NOTE

- Be careful not to damage the piston and piston rings during assembly.
- Carefully install the piston rings onto the piston with the markings facing up.
- Be careful not to be confused between the top ring and second ring.
- Stagger the ring end gaps 120° apart.
- Do not align the oil ring and the side rail end gaps.
- After installing the rings, check that they rotate freely without sticking.

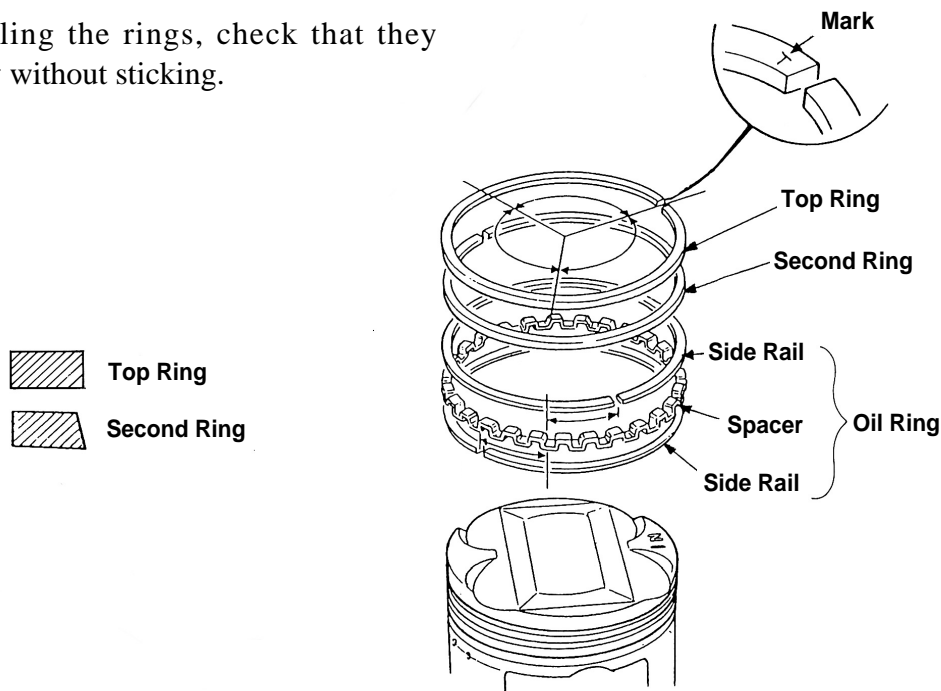

### Piston/Cylinder Installation

- Remove the gasket from the crankcase surface.

#### \*NOTE

- Be careful not to damage the gasket surface.
- Place a shop towel over the crankcase opening to prevent piston pin clips from falling into the crankcase.

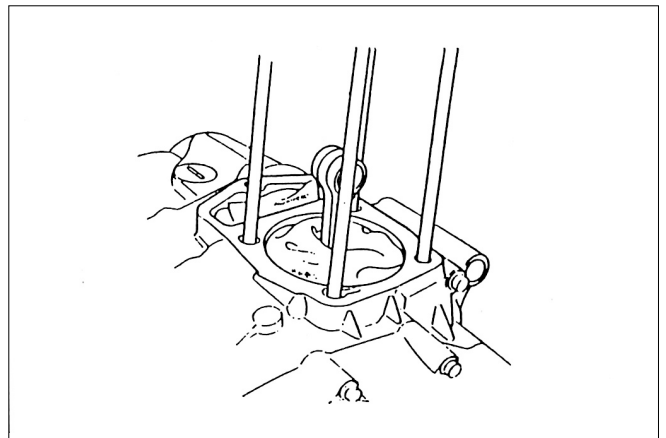

## Cylinder / Piston

- Install the piston, piston pin on the connecting rod.
- Install new piston pin clips.

### \* NOTE

- Install the piston with the “IN” mark facing towards the intake side.
  - Place a shop towel over the opening to prevent piston pin clips from falling into the crankcase.
  - Make sure that the piston clips are seated properly and their end gaps are not aligned with the cutout in the piston.
- Install a new gasket and the dowel pins.

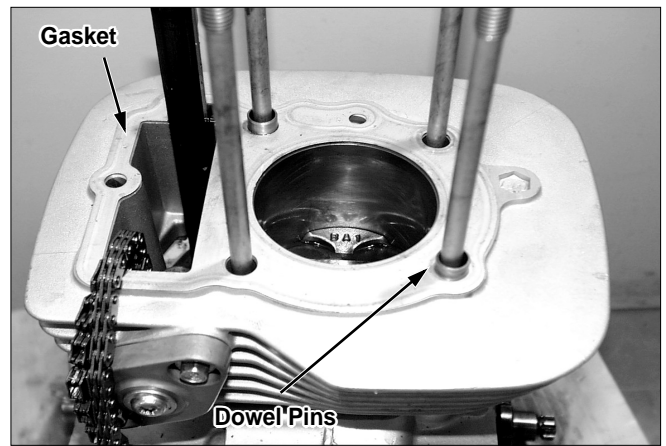
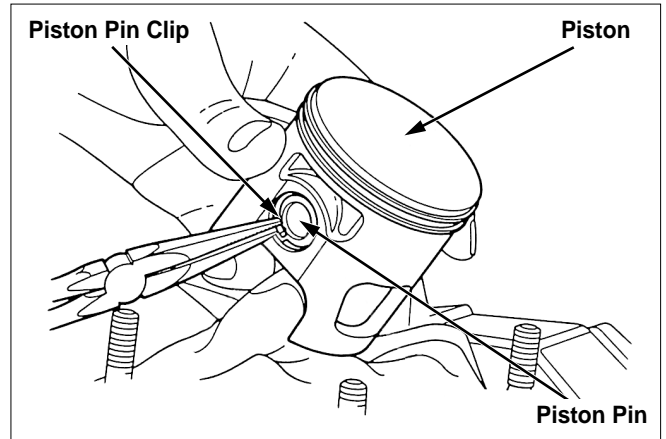

- Coat the cylinder inside, piston rings with clean engine oil and install the piston ring.

### \* NOTE

- Be careful not to damage piston rings.
- Be careful to prevent cam chain from falling into the crankcase.

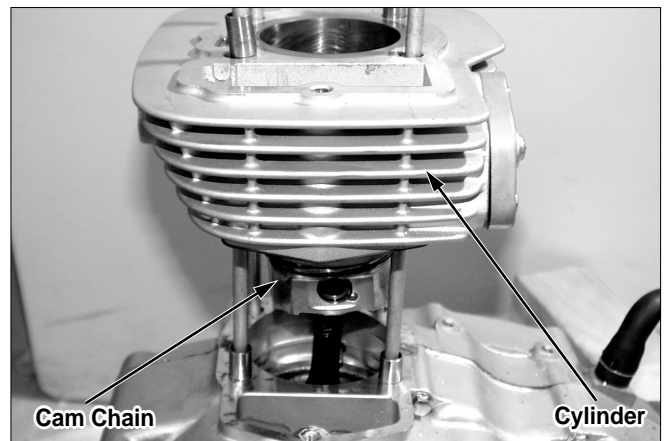

- Install the lower part of the cam chain into the slot of the crankcase.
- Install the cam chain guide, aligning the tang of the crankcase with the slot of the cylinder.
- Install the cylinder head(refer to section 8).

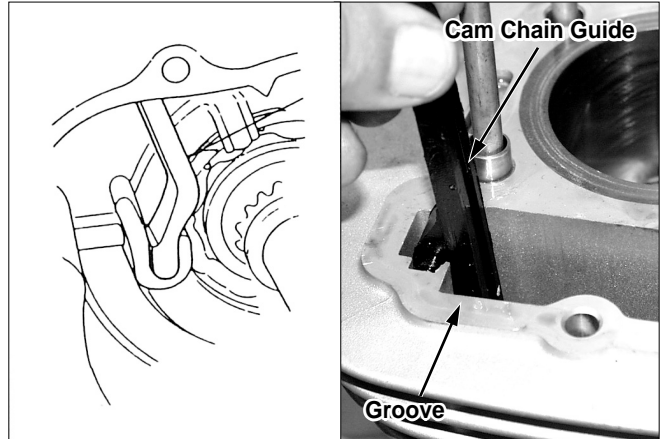



# Crank Case / Transmission / Crankshaft

---

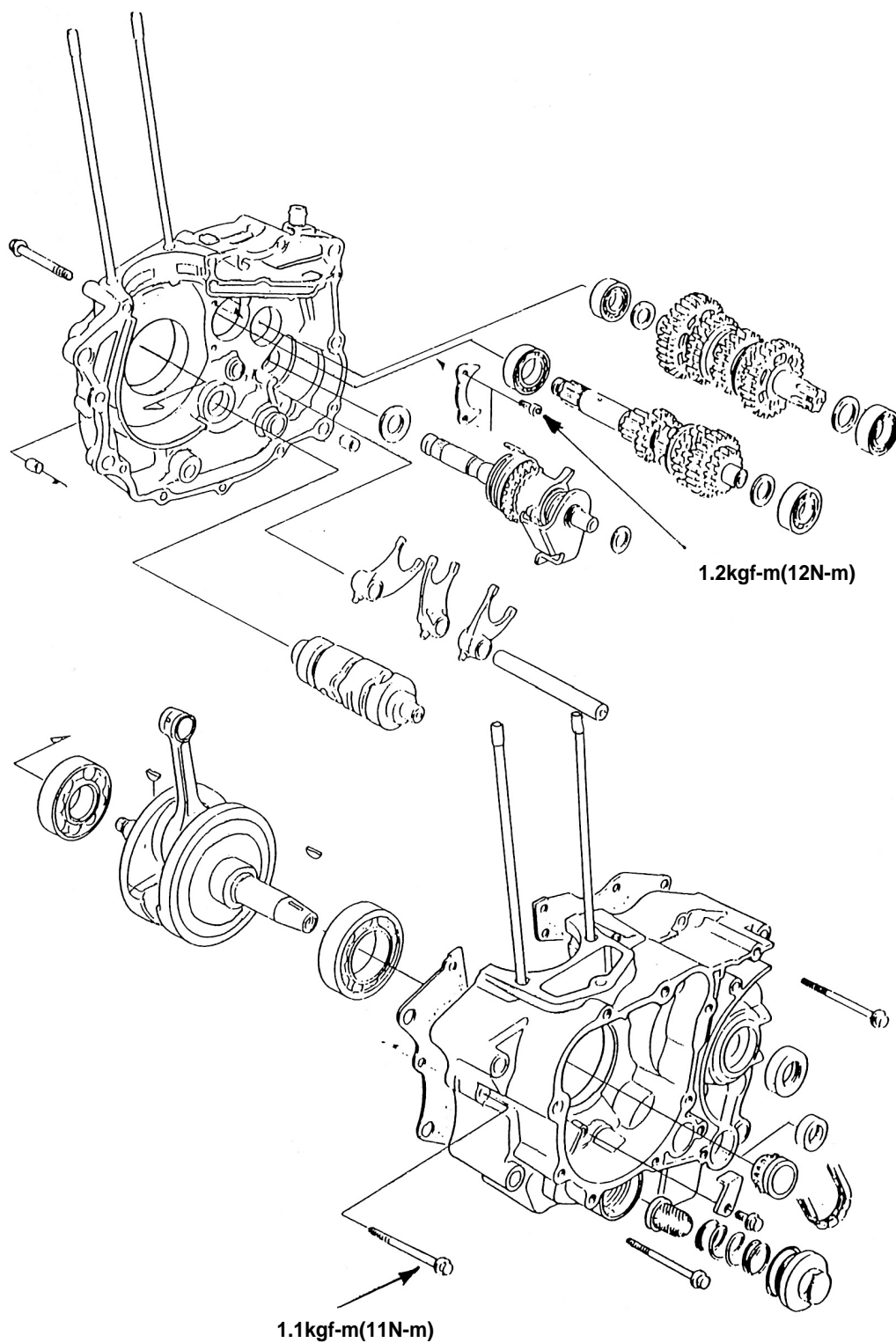

## 10. Crank Case/Transmission/Crankshaft/Kick Starter

<b>Service Information</b> .....	<b>10-1</b>	<b>Crank Case Bearing</b> .....	<b>10-7</b>
<b>Troubleshooting</b> .....	<b>10-2</b>	<b>Crankshaft Installation</b> .....	<b>10-8</b>
<b>Crank Case Disassembly</b> .....	<b>10-3</b>	<b>Transmission Assembly</b> .....	<b>10-9</b>
<b>Transmission Disassembly</b> .....	<b>10-4</b>	<b>Kick Starter</b> .....	<b>10-10</b>
<b>Crankshaft Disassembly</b> .....	<b>10-6</b>	<b>Crank Case Assembly</b> .....	<b>10-12</b>

### Service Information

#### General

- To service the transmission, crank shaft and kick starter, the crank case must be separated.
  - Clutch, gear shift linkage (⇒ section 6)
  - A.C. generator, starter clutch (⇒ section 7)
  - Cylinder head (⇒ section 8)
  - Cylinder, piston (⇒ section 9)
  - Starter motor (⇒ section 18)

#### Specifications

Unit: mm(in)

Item		Standard	Service Limit	
Shift fork/ Shaft	Fork	I.D.	12.000-12.018(0.4724-0.4731)	
		Pole thickness	4.93-5.00(0.194-0.197)	
	Shaft O.D.	11.976-11.994(0.4715-0.4722)	11.96(0.471)	
Transmission	Main shaft O.D.	M3, M5	19.959--19.980(0.7858-0.7866)	
	Counter Shaft O.D.	C1	16.466-16.484(0.6483-0.6490)	16.440(0.6472)
		C2	19.974-19.987(0.7864-0.7869)	19.940(0.7850)
		C4	19.959-19.980(0.7858-0.7866)	19.930(0.7846)
	Gear I.D.	M5		
		M3, C2	23.020-23.041(0.9063-0.9071)	23.070(0.9083)
		C4	20.020-20.041(0.7882-0.7890)	20.070(0.7902)
	Gear bushing O.D.	C1	20.000-20.021(0.7874-0.7882)	20.050(0.7894)
		M5		
		M3, C2	22.979-23.000(0.9047-0.9055)	22.950(0.9035)
	Gear-to-bushing I.D.	C1	19.959-19.980(0.7858-0.7866)	19.930(0.7846)
		M3, C2	20.000-20.021(0.7874-0.7882)	20.050(0.7894)
Gear-to-bushing clearance	C1	16.500-16.518(0.6496-0.6503)	16.550(0.6516)	
	M3, M5 C1, C2	0.020-0.062(0.0008-0.0024)	0.100(0.004)	
Gear to-shaft clearance	C4	0.040-0.082(0.0016-0.0032)	0.120(0.005)	

## Crank Case / Transmission / Crankshaft / Kick Starter

Item		Standard	Service Limit
Transmissin	Bush-to-shaft clearance	M3	0.20-0.062(0.0008-0.0024)
		C1	0.016-0.052(0.0006-0.0020)
		C2	0.013-0.047(0.0005-0.0019)
Crankshaft	Connecting rod big end side clearance		0.05-0.3(0.002-0.012)
	Connecting rod bid end vertical direction clearance		0-0.008(0-0.0003)
	Crankshaft runout	Right	—
		Left	—
Kick starter	Piston Gear I.D.	20.000-20.021(0.7847-0.7882)	20.05(0.789)
	Spindle O.D.	19.959-19.980(0.7858-0.7866)	19.90(0.783)

### Torque Values

Main shaft bearing setting plate 1.2kgf-m(12N.m)

Crank case bolt 1.1kgf-m(11N.m)

### Tools

Special

Universal Bearing Puller

Bearing Remover Set, 15mm

Remover Ass'y 15mm

Remover Shaft

Remover Head

Sliding Weight

Thread Adapter

Assembly Shaft

Crank Case Assembly Collar

## Trouble Shooting

### Hard to shift

- Incorrect clutch system adjustment (Free play is too big)
- Shift fork bent
- Shift fork shaft bent
- Gear shift spindle claw bent
- Shift drum guide grooves damaged
- Shift drum guide pin damaged.

### Transmission jumps out of gear

- Gear dogs worn
- Shift fork shaft bent
- Shift drum stopper damaged
- Shift drum guide grooves worn
- Gear shift fork slot worn

### Engine noise

- Connecting rod big end bearing worn
- Connecting rod bent
- Crank shaft main bearing worn
- Transmission gear worn

### Poor kick starter operation

- Kick starter ratchet dogs worn, damaged
- Kick starter pinion gear damaged
- Ratchet guide plate worn, damaged
- Incorrect kick starter ratchet assembly

## Crankcase Disassembly

- The engine must be separated from the frame (⇒ section 5)
- Refer to the service information for removal of necessary parts before disassembling the crankcase. Remove the cam chain set plate and cam chain.
- Remove the gear change switch.
- Remove the 6mm bolt form right crank case.

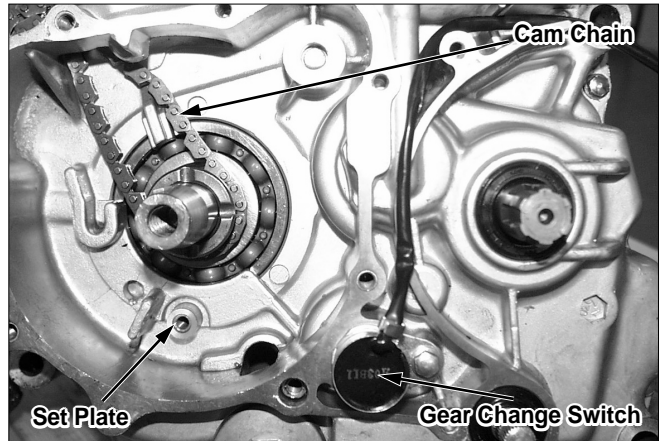

- Remove the crank case breather tube.
- Loosen the ten 6mm crankcase bolts in a crisscross pattern in 2~3 steps, remove the bolts.
- Place the crank case down, and separate the right crank case from the left crankcase by tapping the crank case with a soft hammer.

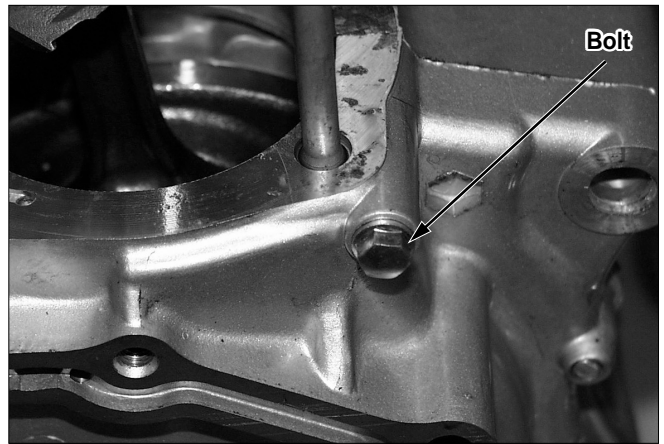

**\* NOTE**

- Do not remove the crankcase mating surfaces crookedly.
- Remove the dowel pins and gasket.

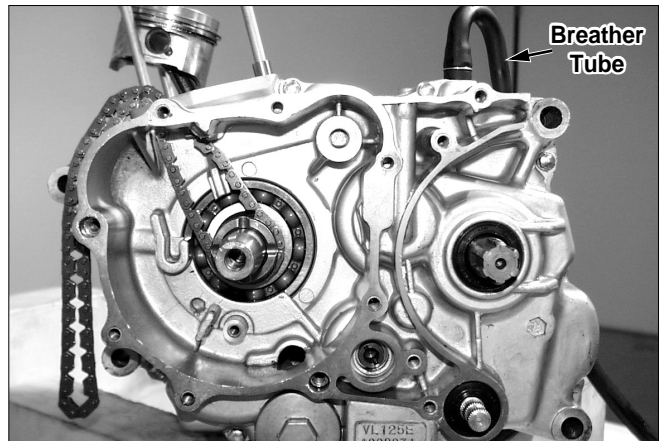

## Transmission Disassembly

- Remove the shift fork shaft.
- Separate the shift fork and the shift drum.

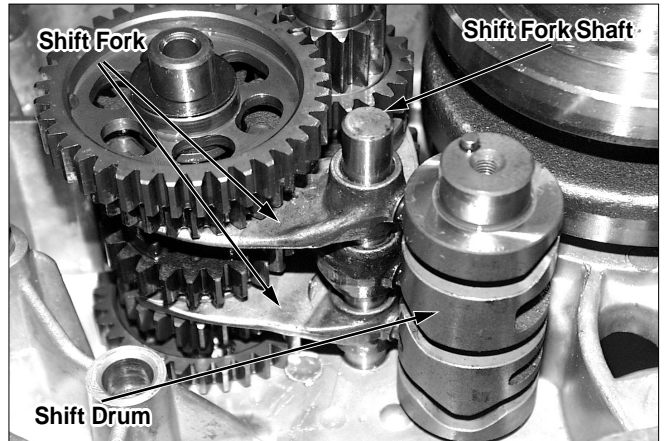

- Remove the main shaft and the counter shaft.
- Disassemble the main shaft and the counter shaft.

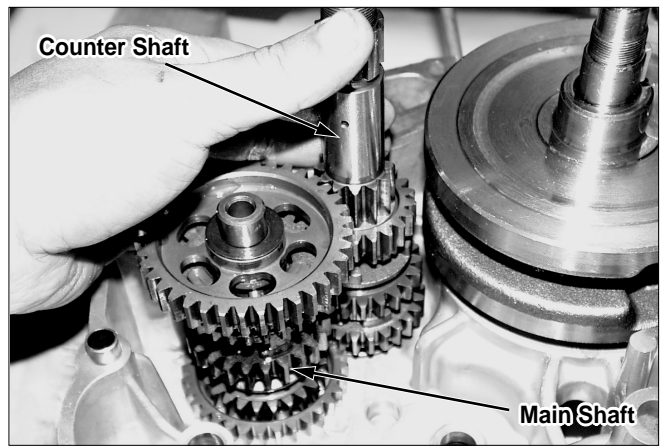

## Inspection

- Inspect the shift fork for wear and damaging.
- Measure the shift fork inside diameter and projecting parts thickness in shift fork.

Service Limit:

Inside diameter: 12.05mm(0.474in)

projecting parts thickness: 4.5mm(0.18in)

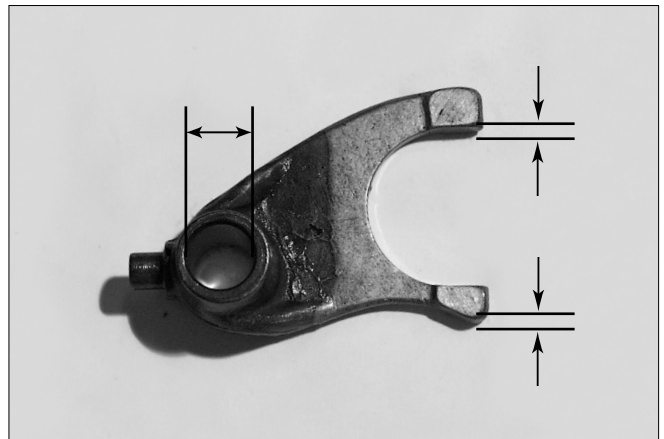

- Inspect the shift fork shaft for wear and damaging.
- Measure the shift fork shaft outside diameter in friction part.

Service Limit: 11.96mm(0.47in)

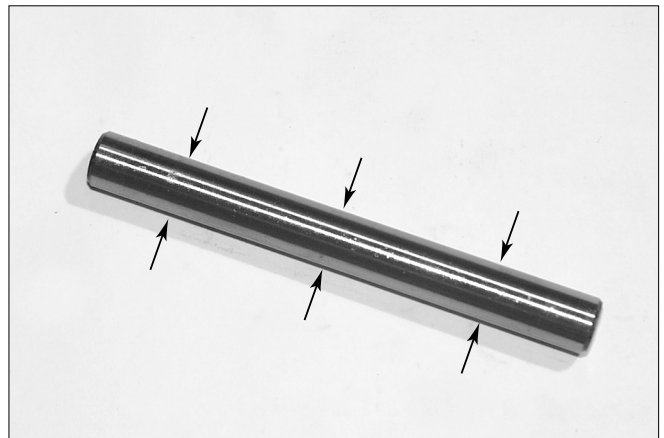

- Inspect the shift drum for wear and damaging.
- Inspect the shift drum guide groove for partial wear and damaging.



- Measure the main shaft and counter shaft outside diameter.

Service Limit: M3, M5:19.930mm(0.7486in)  
 C1:16.440mm(0.6472in)  
 C2:19.940mm(0.7850in)  
 C4:19.930mm(0.7846in)

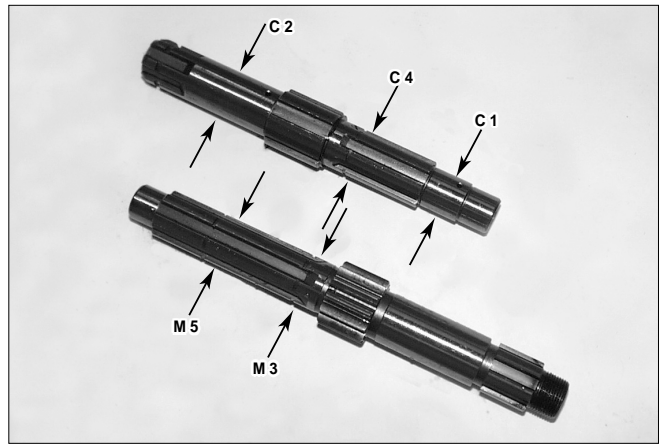

- Inspect the gear for hole, projection part in gear, shift groove, gear wear, and damaging.

- Measure the gear inside diameter.

Service Limit:M5, M3, C2:23.070mm(0.9083in)  
 C4:20.070mm(0.7902in)  
 C1:20.050mm(0.7894in)

- Measure the gear bush inside diameter and outside diameter.

Service Limit:  
 M5, M3, M2 outside diameter: 22.950mm (0.9035in)  
 C1 outside diameter: 19.930mm(0.7846in)  
 M3, C2 inside diameter: 20.050mm(0.7894in)  
 C1 inside diameter: 16.550mm(0.6516in)



- Measure out the gear-to-bush clearance.

Service Limit:  
 M3, M5, C1, C2: 0.10mm(0.004in)

- Measure out the gear-to-shaft clearance.

Service Limit: C4:0.12mm(0.005in)

- Measure out the bush-to-shaft clearance.

Service Limit:M3:0.10mm(0.004in)  
 C1:0.09mm(0.004in)  
 C2:0.09mm(0.004in)

## Crankshaft Disassembly

- Disassemble the transmission.
- Remove the crankshaft from the left crankcase using a crankshaft separating tool. Remove the remaining bearings in the left crankcase with a driver handle and outer driver.

Tools:

Driver

Attachment 42 × 47mm

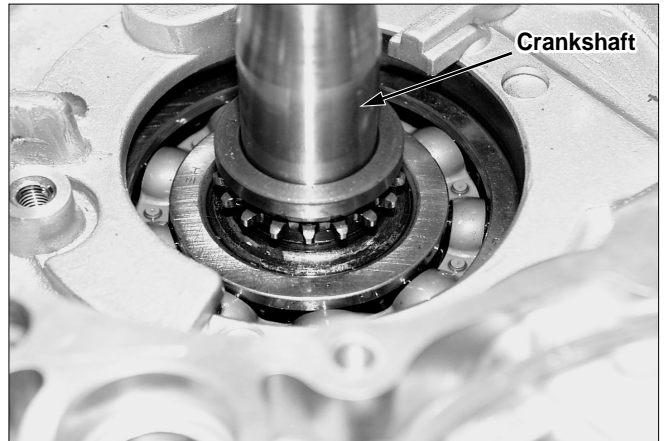

- Remove the remaining bearings in the crankshaft with a bearing puller.
- Tool: Universal bearing puller

**\* NOTE**

- If the crankshaft is removed from the left crankcase, a new left crankshaft bearing must be used.

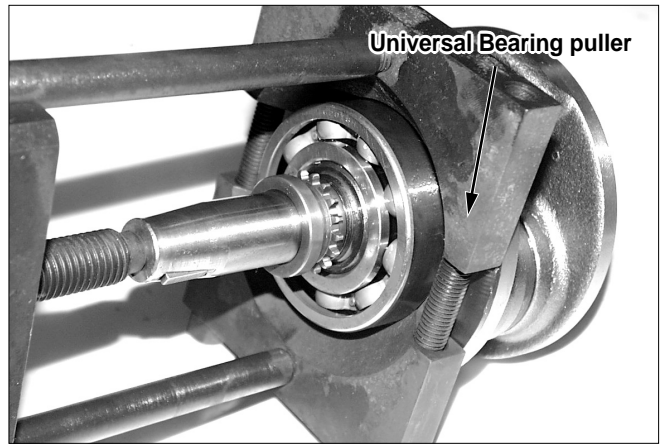

## Inspection

- Install the crank shaft into the stand or V-block and measure the vibration of journal part.

Service Limit: Right: 0.1mm(0.004in)

Left: 0.1mm(0.004in)

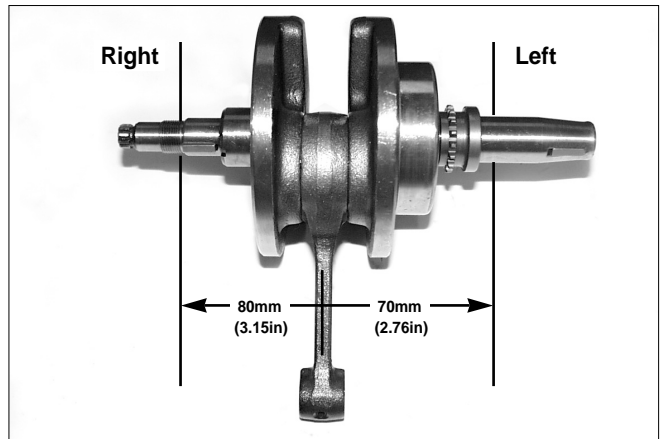

- Measure the side gap of connecting rod end and crank weight.

Service Limit: 0.6mm(0.02in)



- Measure the state of vertical flux of the Connecting Rod end by X and Y direction.  
Service Limit:0.05mm(0.002in)

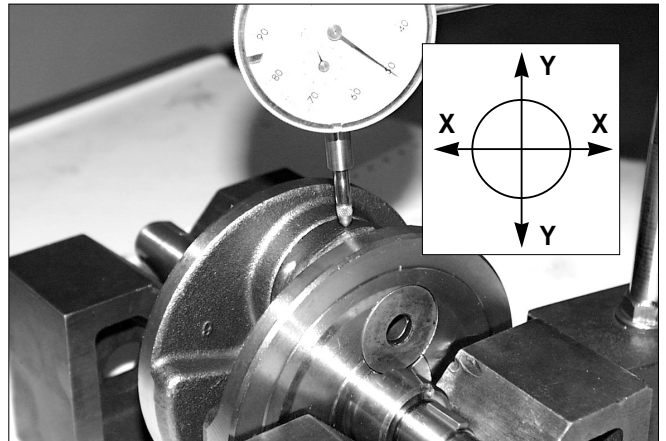

## Crankcase Bearing

- Remove the transmission and crank shaft.

### Inspection

- Turn the Inner race of bearing with fingers and inspect for smooth turning. Also inspect that the outer race is driven into the case exactly. If the clearance is excessive, or the driving for the case is loose, remove and replace them.

### ⚠ CAUTION

- Replace the transmission bearing with the right and left sets.

### Replacement

#### L. Crankcase

- Remove the main shaft bearing with the tools.  
Tool: Bearing remover set 15mm
  - Remover ass'y 15mm
  - Sliding weight
  - Remover shaft
  - Remover head
- Remove the counter shaft bearing and oil seal.
- Coat the new bearing with clean engine oil, and install it into the crank case.  
Tool:  
Main shaft bearing:
  - Driver
  - Attachment, 32 × 35mm
 Counter shaft bearing:
  - Driver
  - Attachment, 42 × 47mm
  - Pilot, 20mm
- Install the new counter shaft oil seal.
- Inspect the gear shift spindle oil seal for wear and damaging, must be replaced if necessary.

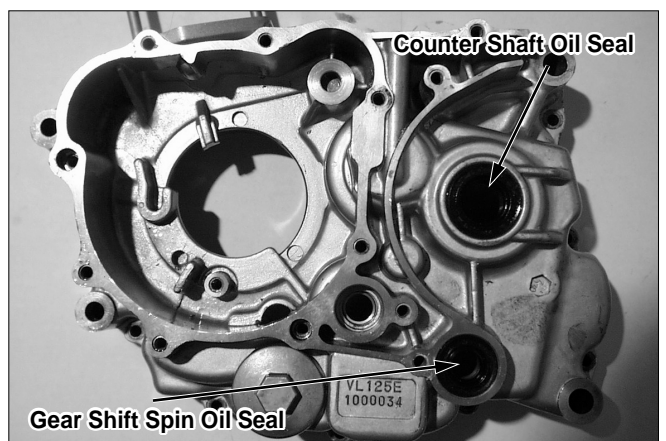
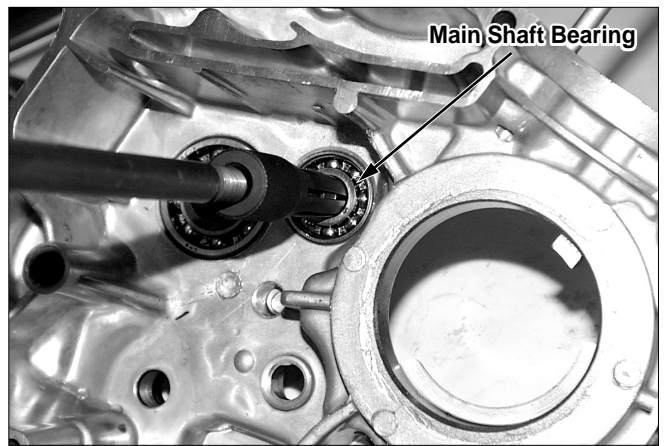



## Crank Case / Transmission / Crankshaft / Kick Starter

### R. Crank Case

- Remove the main shaft bearing set plate.
- Separate the main shaft bearing, counter shaft bearing and crank shaft bearing from crank case.
- Coat the new bearing with clean engine oil and install it into crank case.

- Insert closely the cooling jet into crank case
  - Insert angle:  $10^{\circ} \pm 2^{\circ}$

Tool :

Main Shaft bearing:

- Driver / Attachment, 42 × 47mm / Pilot, 20mm

Counter shaft bearing:

- Driver / Attachment, 32 × 35mm / Pilot, 15mm

Crank shaft bearing:

- Driver / Attachment, 62 × 68mm / Pilot, 28mm

- Coat the socket bolt screw part with oil and install the main shaft bearing set plate.

Torque: 1.2kg-m

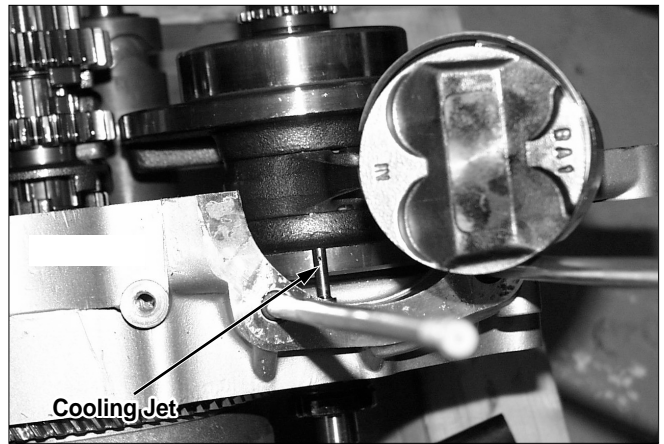
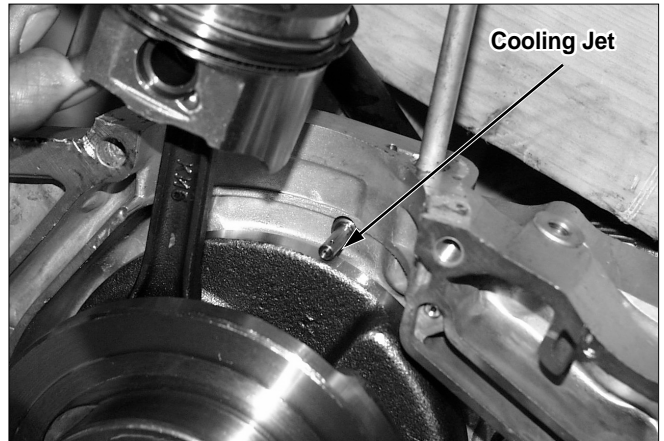

## Crankshaft Installation

- Coat a new light crankshaft bearing with clean engine oil and install new bearings into the light crank case.

Tool:

- Driver
- Attachment, 72 × 78mm
- Pilot, 35mm

- Install the crankshaft into the left crankcase with the following tools

Tools:

- Thread adapter
- Assembly shaft
- Crankshaft assembly collar

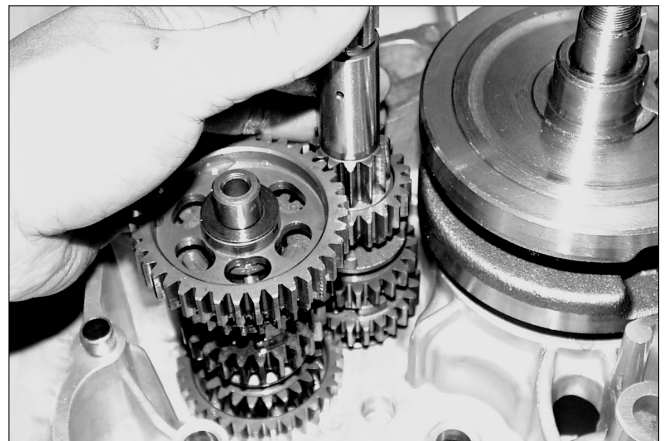

## Transmission Assembly

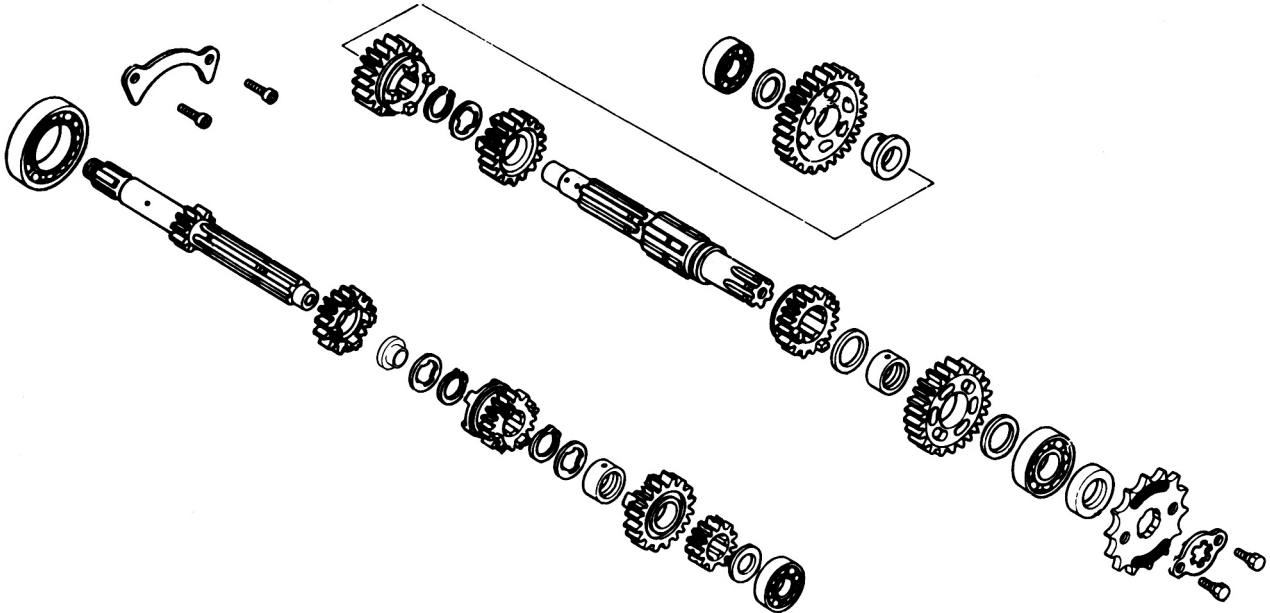

- Coat the gear and gear bush with clean engine oil and install the mainshaft and counter shaft.
- Check the gears for freedom of movement or rotation on the shaft.

**\* NOTE**

- Note the installation direction of each snap ring.  
Do not use the worn snap ring again.  
Check the snap rings are seated in the grooves spinning the rings. Align the end gaps of the snap ring with the grooves of spline.
- Install the mainshaft and countershaft into the left crankcase together.

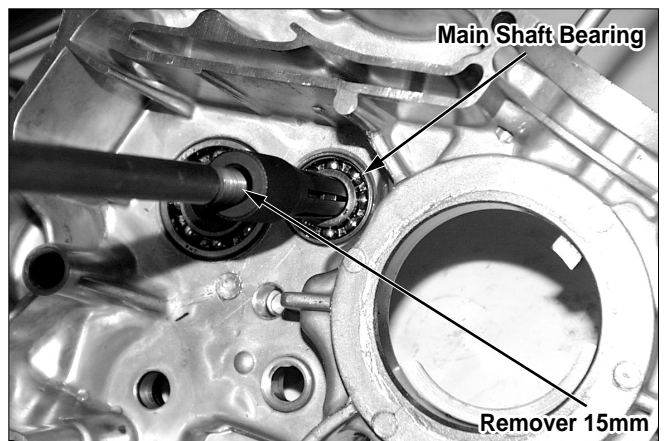
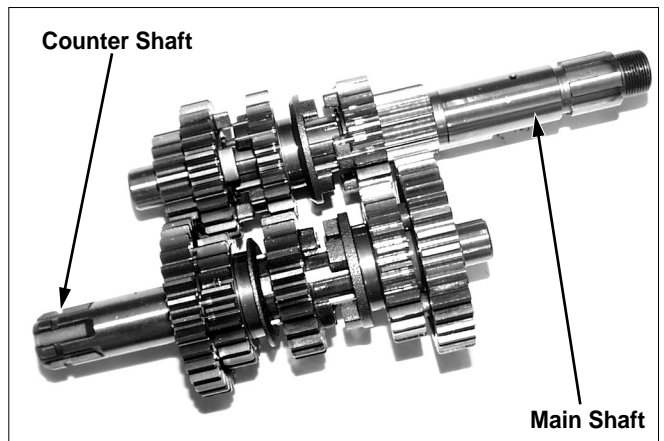

## Crank Case / Transmission / Crankshaft / Kick Starter

- Check the marks on the shift forks.

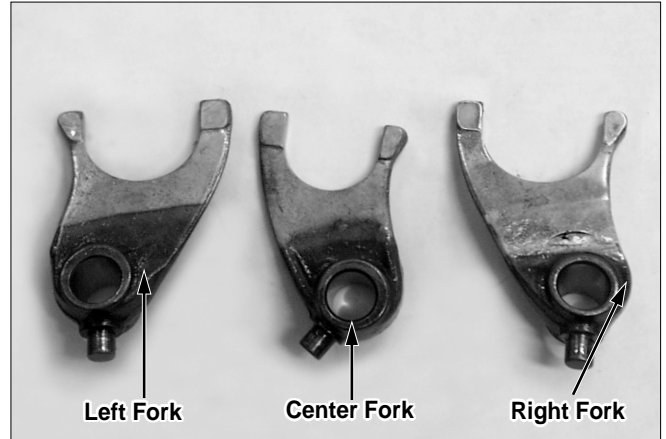

- With the left fork mark and center fork mark facing down, assemble them.
- Install the shift drum. Install the shift fork guide pin into the guide groove of the drum.

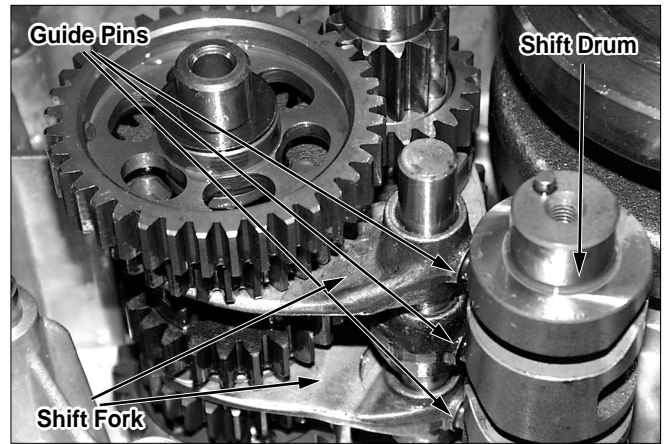

- Install the shift fork into the shift fork shaft, then install the shift fork into the left crankcase assembling hole.

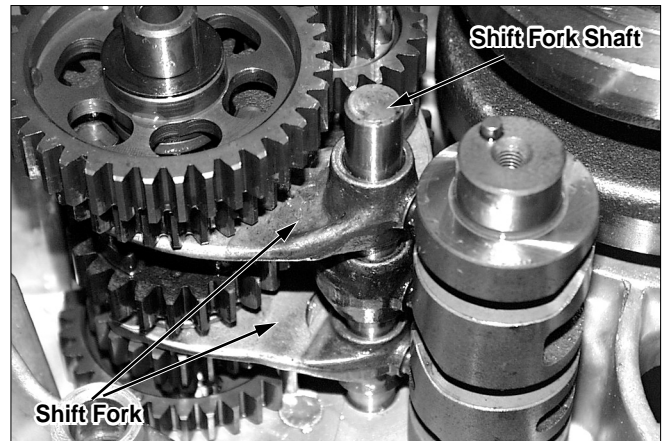

## Kick Starter

### Removal

- Remove the 16mm thrust washer, spindle collar, kick starter spring and spring retainer.

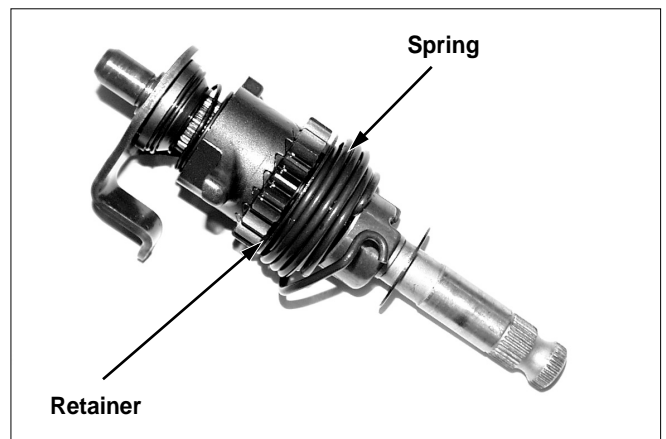

- Remove the 12mm thrust washer, snap ring, ratchet guide, plate, spring, 16mm trust washer and ratchet.

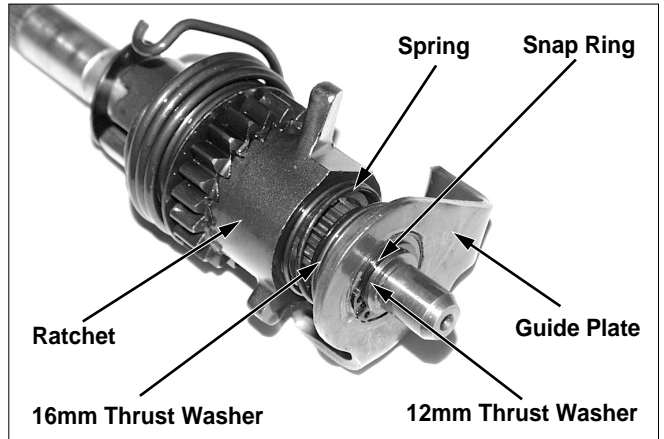

- Remove the snap ring, 20mm thrust washer, and pinion gear.

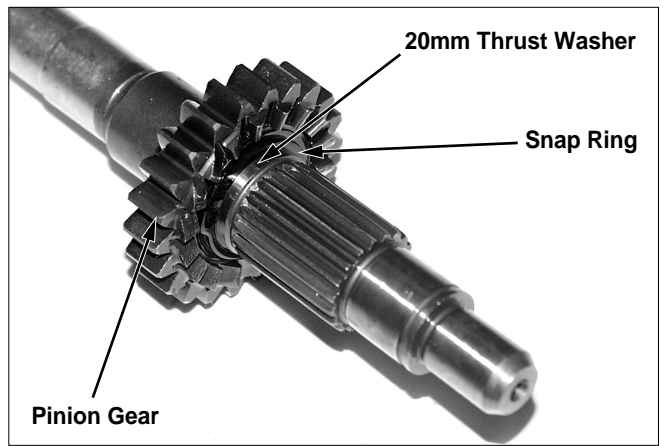

### Inspection

- Inspect each parts for wear and damaging, replace them if necessary.



- Measure the kick starter spindle outside diameter in the pinion gear part.  
Service Limit: 19.90mm (0.783in)
- Measure the pinion gear inside diameter.  
Service Limit: 20.05mm (0.789in)

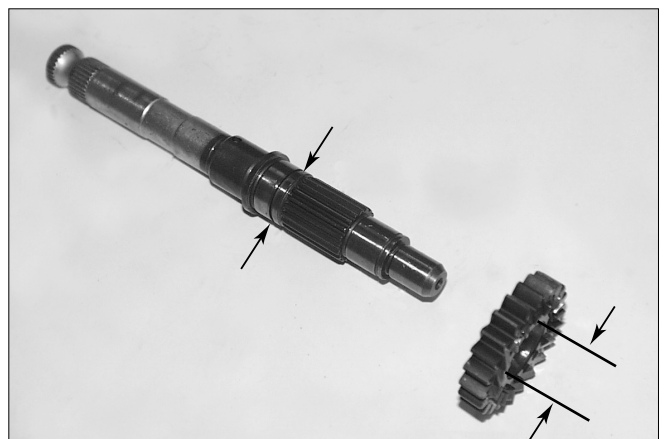

## Crank Case / Transmission / Crankshaft / Kick Starter

### Installation

- Coat the pinion gear with clean engine oil.  
Install the gear into the 20mm thrust washer and tighten them with the snap ring.
- Install the kick starter ratchet into the spindle, aligning the punch mark.

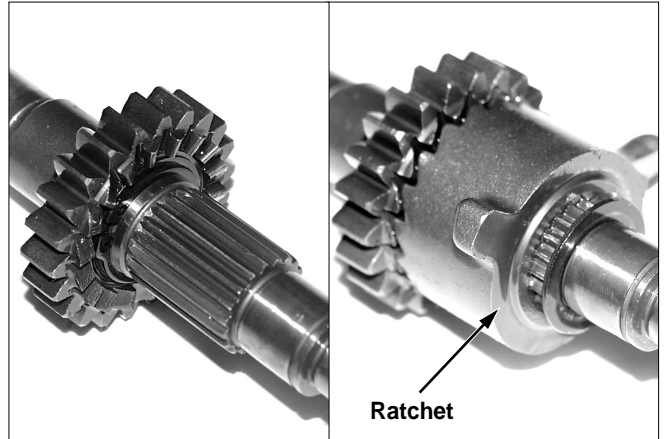

- Install the 16mm thrust washer.
- Install the ratchet spring into the ratchet guide plate as shown and tighten them with the snap ring.
- Install the 12mm thrust washer.

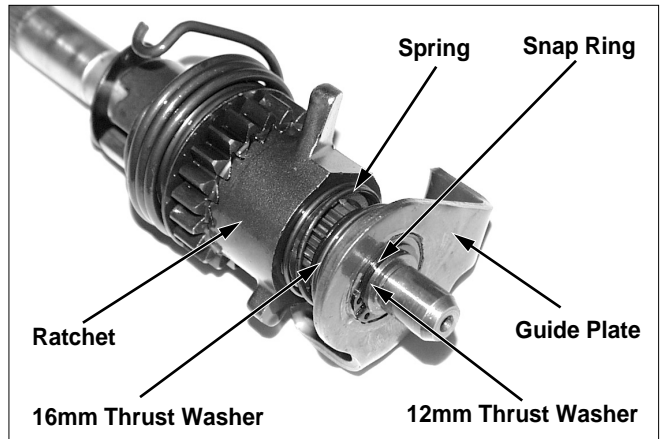

- Install the spring retainer and kick starter spring and insert the end of the spring pin into the spindle hole.
- Align the spindle collar end gap with the end of the spring.
- Install the 16mm thrust washer.

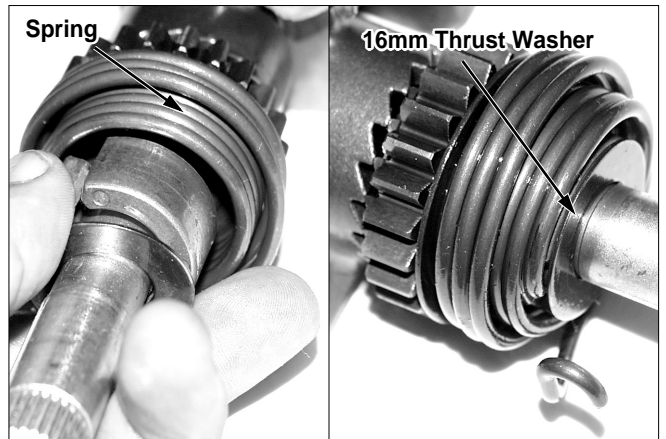

### Crankcase Assembly

- Install the dowel pins and a new gasket.



- Install the kick starter into the right crankcase, hanger the end of the kick starter spring on the case hole.

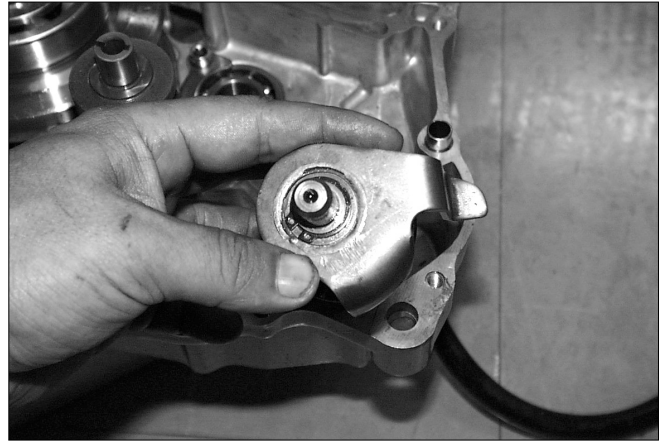

- Turn the ratchet and ratchet guide plate to the right and place them as shown.

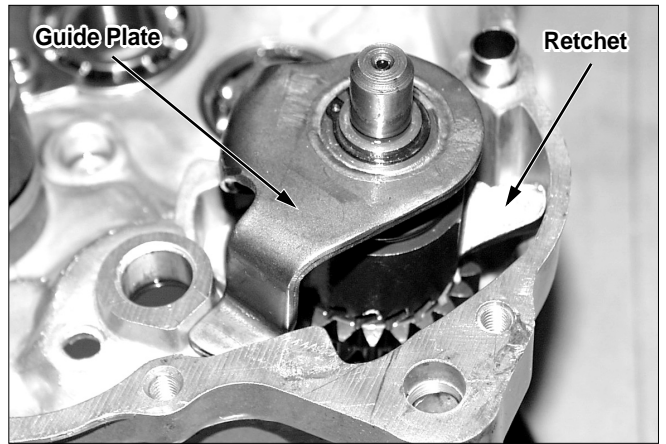

- Be careful to prevent 12mm kick starter thrust washer from falling. Install the right crankcase into the left crankcase while pressing the kick starter to prevent the ratchet and guide plate from falling.



- After installation of the kick starter pedal temporarily, turn the kick starter to the right slowly to align the end of the spindle with the left crankcase assembling hole thoroughly.

**\*NOTE**

- Make sure that there is no gap between the mating surfaces of the right and left crankcase.

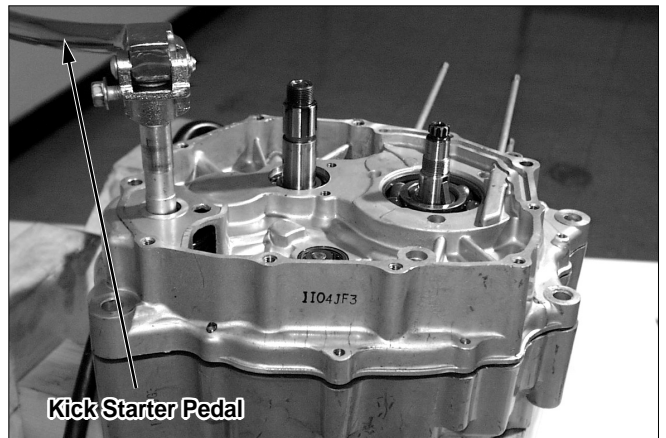

## Crank Case / Transmission / Crankshaft / Kick Starter

- Tighten the left crankcase bolt in a crisscross pattern in 2-3 steps.  
Torque: 1.1kgf-m(11N.m)

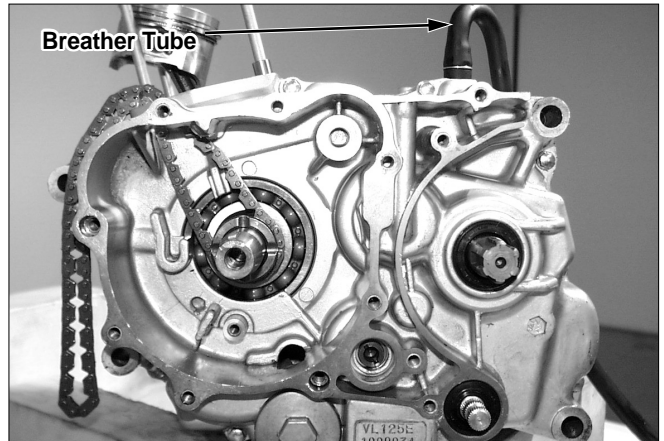

- Tighten the right crankcase bolt.  
Torque: 1.1kgf-m(11N.m)

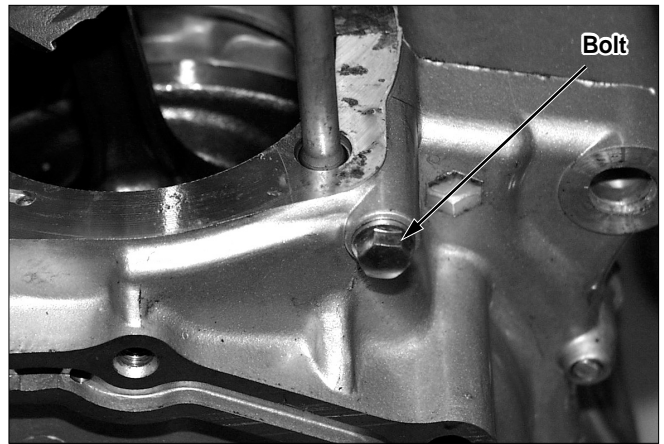

- After replacing the o-ring of the gear change switch to a new one, coat the new o-ring with engine oil, then install the switch pin into the groove of the shift drum.

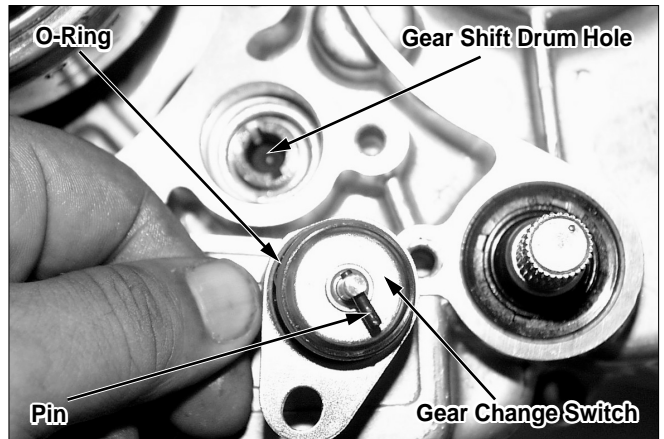

- Install the cam chain and set plate.
- Install the disassembled parts.
- Install the engine on the frame. (⇒Section 5)

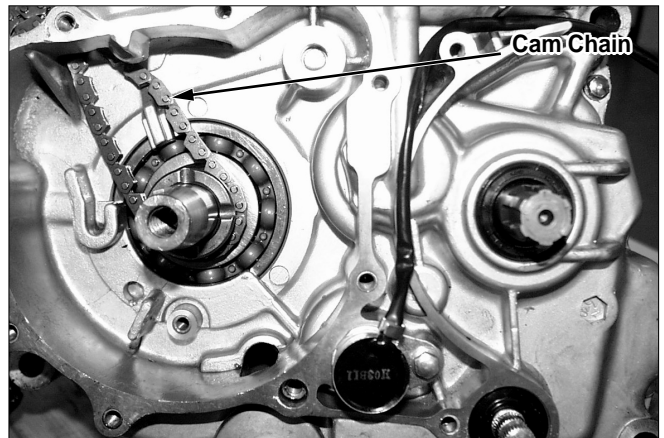

# 11. Cooling System

<b>Service Information</b> .....	<b>11-1</b>	<b>Radiator</b> .....	<b>11-2</b>
----------------------------------	-------------	-----------------------	-------------

## Service Information

### General

- The engine must be cool before servicing the cooling system.



# Radiator

### Removal

- Remove the radiator grill
- Remove the radiator from the frame.
- Loosen the oil through bolt from the cylinder, and remove the radiator hose R.L
- Loosen the oil through bolt from the radiator, and remove the radiator hose R.L

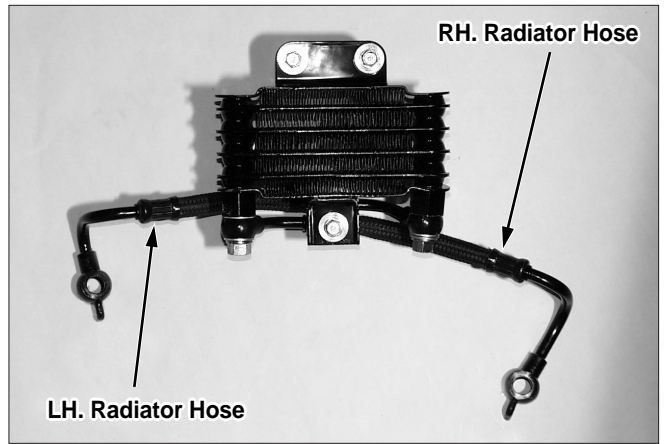

### Radiator Hose Inspection

- Check if the radiator core is choked up or bended
- When bend of pin adjust the driver.
- Inspect the hose or clamp of damage.

Replace the radiator when the choked area of radiator core is over 20% of radiant heat area.

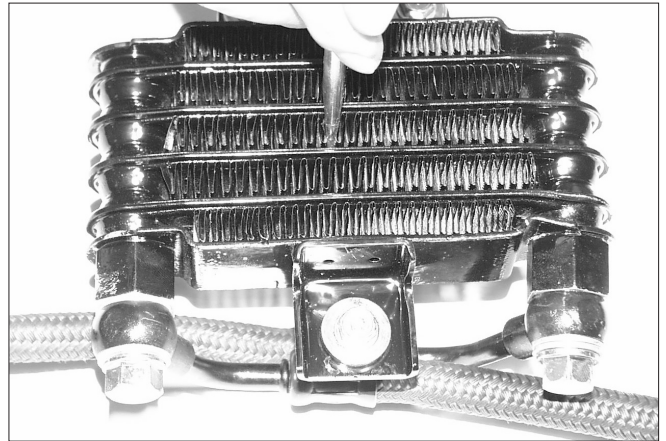

## 12. Seat/Exhaust Muffler

Service Information .....	12-1	Rear Fender .....	12-3
Side Cover, Seat .....	12-2	Muffler .....	12-3
Grab Rail .....	12-2	Tool Box.....	12-4

### Service Information

**⚠ CAUTION**

- Muffler is very hot after engine stops. Avoid inspection right after engine stop.

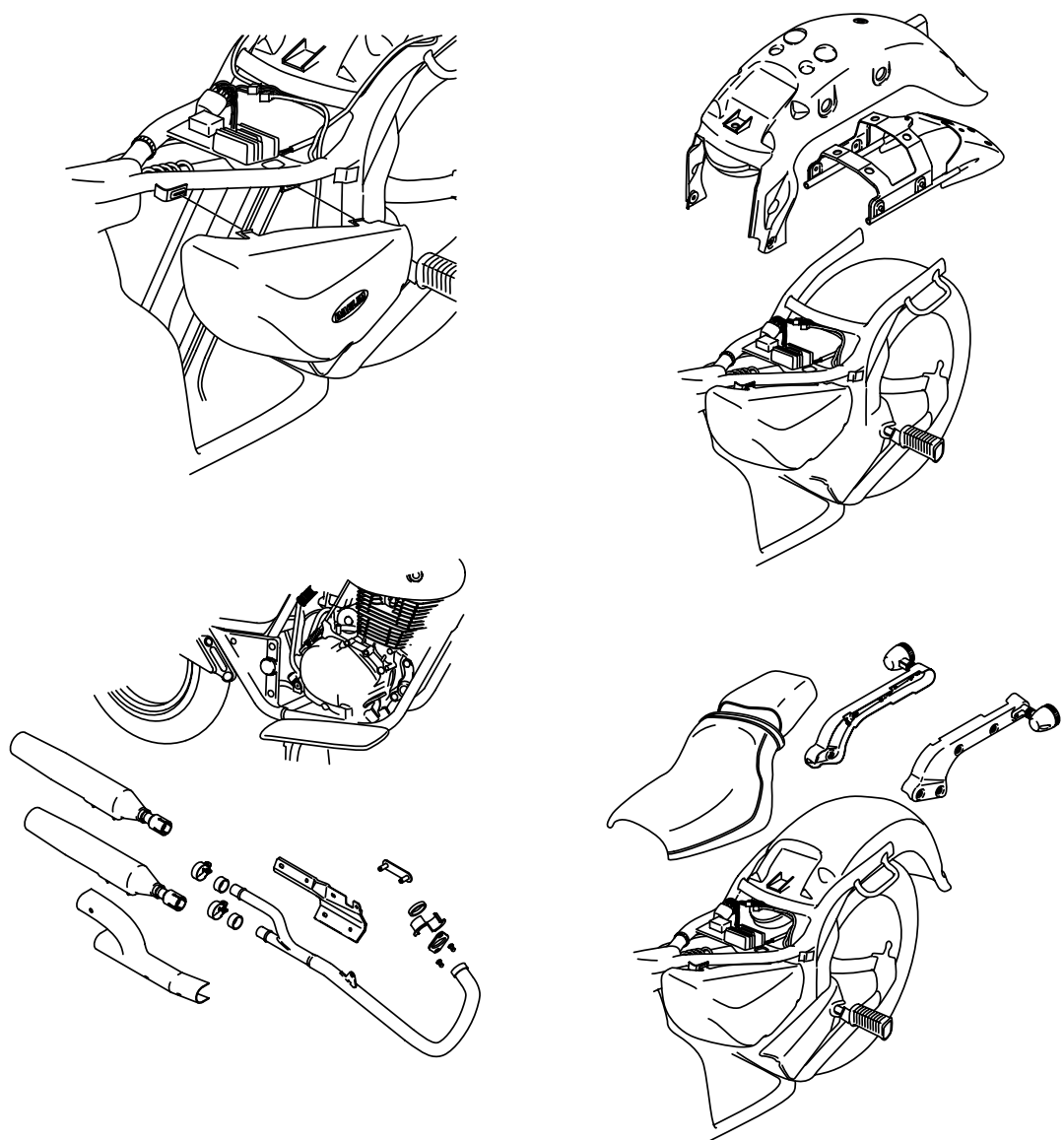

### Side Cover/Seat

#### Side Cover Removal

- Remove the R.side cover. (Removing with a lock key)
- Loosen the screw with a “+” driver
- Separate the side cover hook from grommet of frame.  
(When removing, remove the side cover with pushing toward the down.)



#### Seat Removal

- Remove 3 flange bolts (1 left, 1 right, 1 rear) and remove the seat by pulling the seat toward the back.)



#### Assembly

- Assembly is done the reverse order of disassembly.

### Grab Rail

#### Removal

- After removing the seat remove the rear winker and tail light code.
- Remove the left, right cap nut/bolts (each 4EA) of the grab rail. (After removing, push the stay pinch bolt to the inside.)

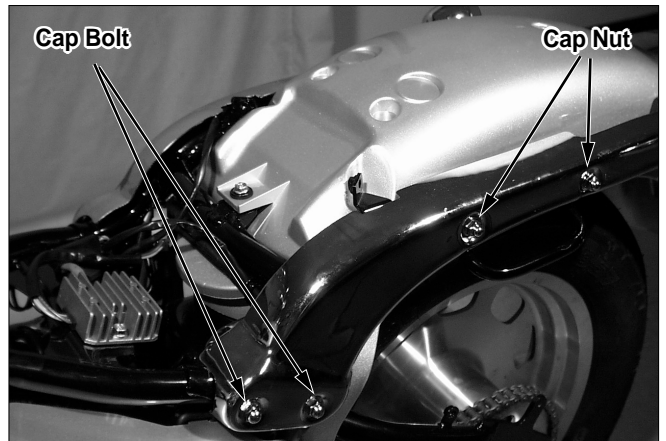

#### Assembly

- Assembly is done in the reverse order of disassembly.

## Rear Fender

### Removal

- Separate the seat and remove the code connection.
- Remove the grab rail.  
(After removing, push the stay connecting bolt toward the inside.)
- Remove the rear fender.  
(Tail light is attached.)
- Loosen the inside screws of rear fender. After removing the green connector of inside socket, remove the tail light.
- Assembly is done in the reverse order of disassembly.



## Muffler

### \*NOTE

- Do not service the exhaust system when it is not.

### Removal

- Loosen the 2 muffler pipe cap nut.
- Loosen the flange bolt from muffler pipe comp.
- Remove the 2 flange nut from upper muffler stay.
- Assembly is done in reverse of disassembly.

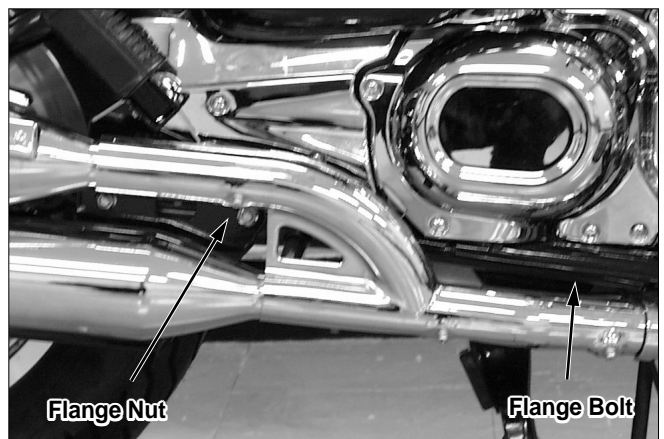

## Seat/Exhaust Muffler

---

### Muffler Removal/Assembly

- Loosen the 3 pan screw of muffler protector and remove the protector.
- Loosen the upper/low muffler band.
- Loosen the 2 flange nut of upper muffler stay and remove the muffler comp

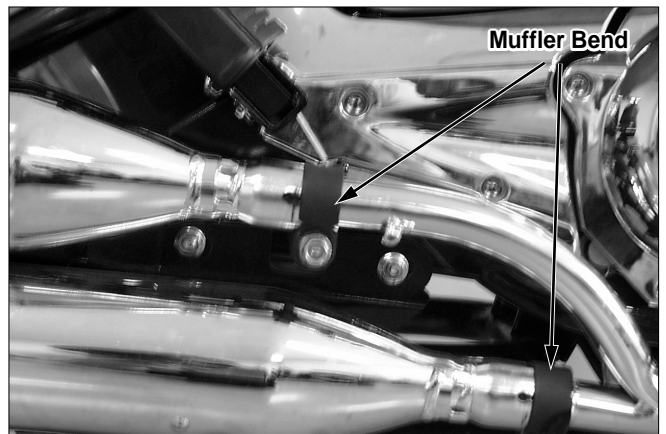

### Tool Box

- Remove the R. front cover (removing with a key.)
- Loosen the tool box stay pinch bolt.
- Assembly is done in reverse of disassembly.

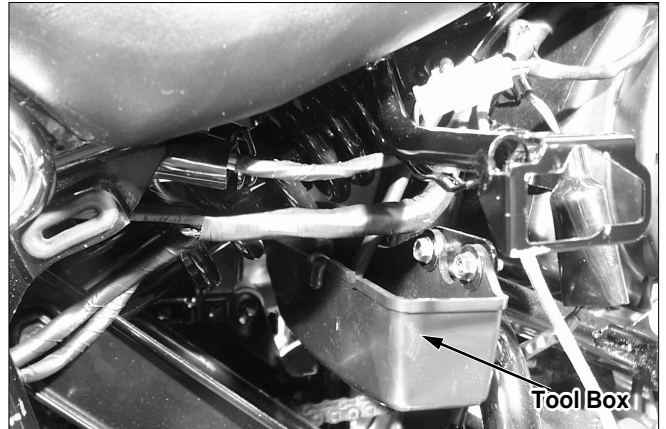



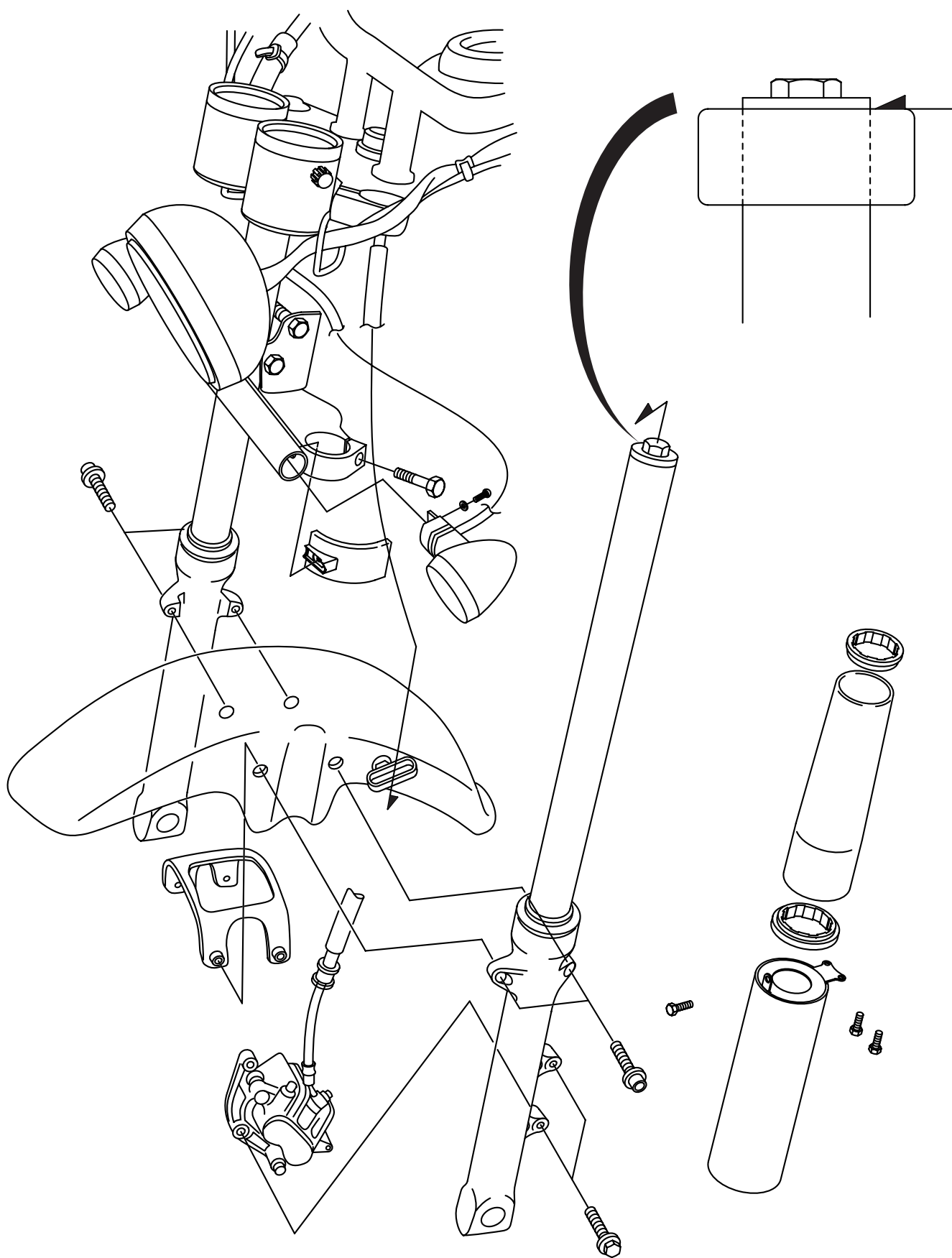

# 13. Front Wheel/Front Fork/Steering

<b>Service Information</b> .....	<b>13-1</b>	<b>Front Wheel</b> .....	<b>13-6</b>
<b>Troubleshooting</b> .....	<b>13-2</b>	<b>Front Fork</b> .....	<b>13-11</b>
<b>Handle Bar</b> .....	<b>13-3</b>	<b>Steering Stem</b> .....	<b>13-18</b>

## Service Information

### General

**⚠ CAUTION**

- Contaminated brake disk and pad reduce stopping power. keep grease off the brake disk and pad. Wipe any excess grease off the disk. Replace the contaminated pad.
- For front brake service information, refer to section 15, Hydraulic brake.
- A special tire lever and a rim protector are required to protect tire rim during removal and installation.
- A jack or other support is required to support the motorcycle during front end service.

### Specification

Unit:mm(in)

Item		Standard	Service Limit
Front Axle Runout		———	0.2(0.008)
Front Wheel Rim Runout	Radical	———	2.0(0.08)
	Axial	———	2.0(0.08)
Front Fork Oil Level		250	———
Front Fork Tube Runout		———	0.2(0.08)
Front Fork Fluid Capacity		280cm <sup>3</sup>	———
Fork Spring Free Length		564.5(22.2)	———

### Torque

Steering Handle Bolt	2.6kgf-m
Brake Disk Nut	4.2kgf-m
Front Axle Nut	5.9kgf-m
Fork Bottom Pinch Bolt	3.3kgf-m
Fork Tube Cap Bolt	2.3kgf-m
Fork Socket Bolt	2.0kgf-m(Apply oil to the thread)
Caliper Bracket Bolt	3.0kgf-m
Steering Stem Nut	7.4kgf-m
Steering Top Thread Nut	1.8kgf-m(Starting torque) 0.3kgf-m(Finishing torque)



### Tools

#### Special

Ball Race Driver  
Steering Stem Driver  
Fork Seal Driver  
Steering Stem Socket

#### Common

Extension Bar  
Driver  
Fork Seal Driver Body  
Lock Nut Wrench 30 × 32mm  
Bearing Remover shaft  
Remover Head  
Attachment 42 × 47mm  
Attachment 37 × 40mm  
Pilot 12mm

## Troubleshooting

### Hard steering

- Steering bearing adjusting nut too tight.
- Steering head, bearing worn, damage
- Inner, outer race worn, damage
- Insufficient tire pressure
- Worn Tire

### Steers to one side

- Steering head bearing damage, loose
- Unevenly adjusted right and left cushions
- Bent front fork
- Bent front axle shaft, wheel installed incorrectly
- Worn tire
- Worn wheel bearings
- Worn swing arm pivot

### Front wheel wobbling

- Bent rim
- Worn wheel bearings
- Spoke bent, loose

### Soft suspension

- Weak fork springs
- Insufficient fluid
- Contaminated oil
- Low fluid weight in fork

### Hard suspension

- Bent fork tubes
- Too much oil
- High fluid weight in fork
- High tire pressure

### Front fork noise

- Faulty bottom case
- Fork assembling part loose
- Insufficient fluid in fork

## handle Bar

### Removal

- Loosen the cable guide bolt and remove the guide.

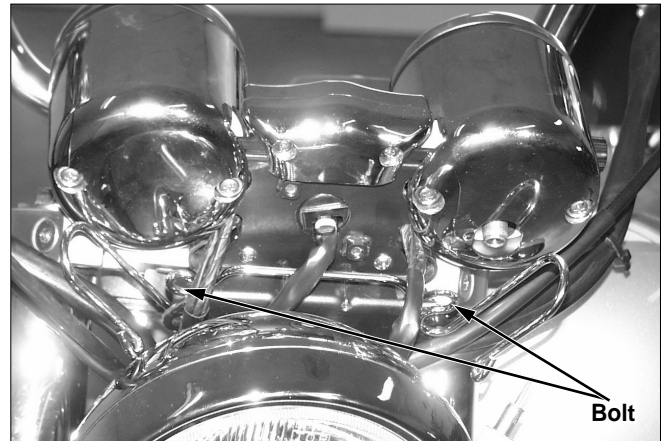

- Remove the starter kick switch, Throttle cable and throttle grip.
- Remove the master cylinder holder socket bolt with L.wrench.
- Remove the master cylinder holder.
- Remove the master cylinder from the handle bar.
- Support the master cylinder in order not to leak brake fluid.

**\* NOTE**

- Master cylinder should be equipped with the frame correctly without fail to avoid an inferior phenomenon, air mixed with the air caused by hungdown equipt master cylinder.

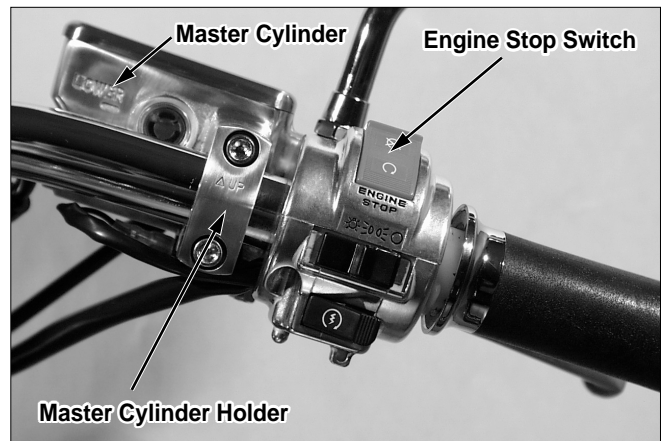

- Remove the winker switch.
- Remove the chock cable out of the choke lever.
- Remove the clutch lever holder.
- Remove the clutch lever from the handlebar.

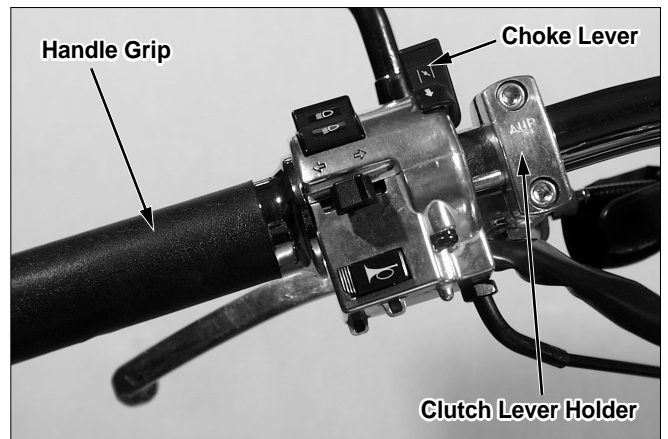

- Loosen the handle connecting nut and washer of fork top bridge.



## Front Wheel/Front Fork/Steering

### Assembly

- Install the handle into the top bridge connecting hole.



- Tighten the handle washer and nut.  
Torque: 2.6kgf-m(26N.m)



- When removing L. handle grip or R. handle grip from the Throttle pipe, clean them preventing the L. handle and throttle pipe attachment part of handle grip with molybdenum.
- After 3-5 minutes, install the grip. Install the grip with turning according to user's manual attached on adhesives.

### ⚠ CAUTION

- After attaching, leave it over 1 hour until drying the adhesives.
- Install the master cylinder into the handle bar with the "UP" mark on the holder facing up.
- Align the mating surface of the master cylinder and holder with the punch mark on the handle bar.
- Tighten the upper socket bolt first then tighten the lower socket bolt.

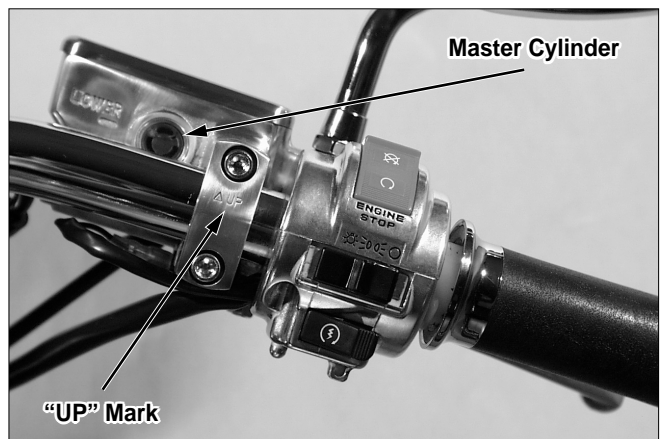
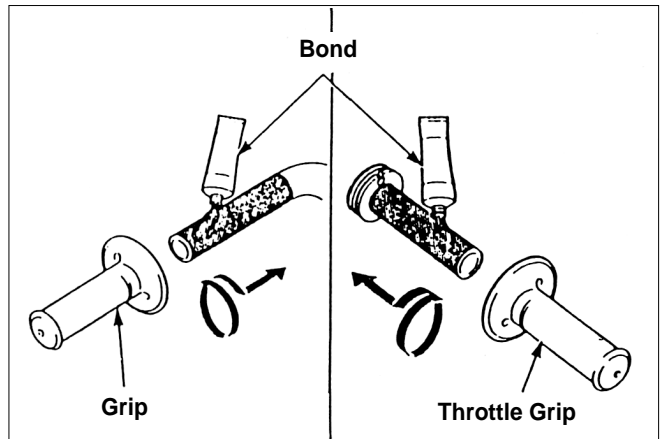

- Apply grease to the ends of the throttle cable.
- Install the throttle cable into the throttle pipe.
- Install the lighting start switch housing mounting holder pin onto the handlebar hole and tighten the mounting holder pin.

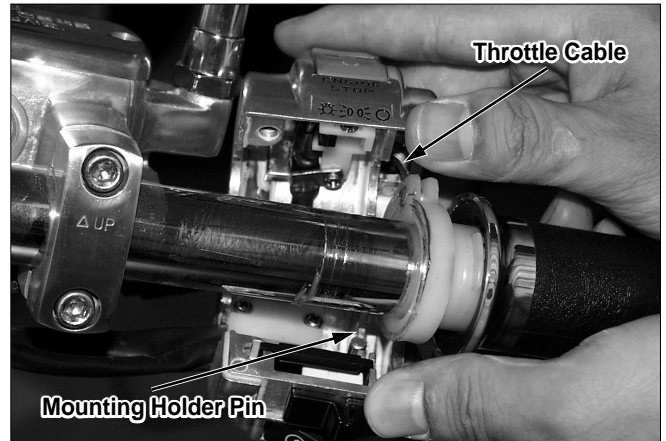

- Tighten the forward screws first, then tighten the rear screws.

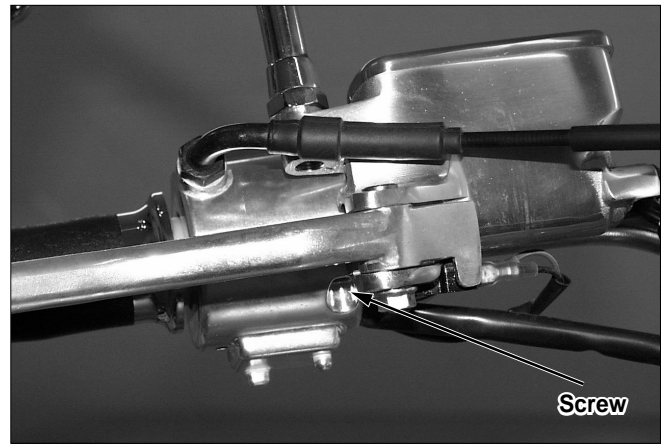

- Install the clutch lever bracket with the holder's "UP" mark facing up.
- Align the mating surface of the clutch lever and holder with the punch mark on the handle bar and tighten the upper bolt first and then tighten the lower bolt.

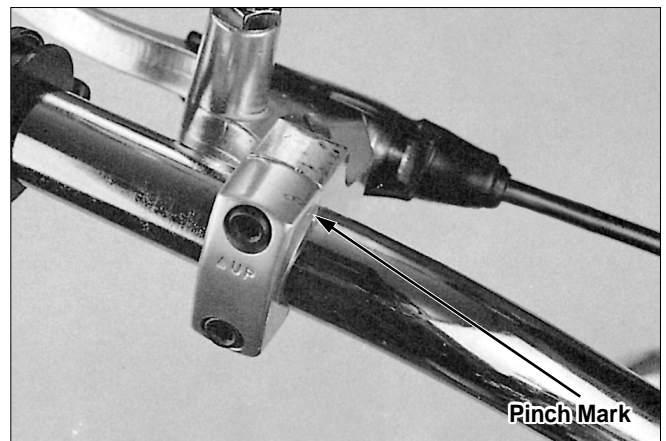

- Connect the choke cable to the choke lever.
- Align the mounting bolt of the winker switch housing with the handle bar hole and tighten the mounting bolt.

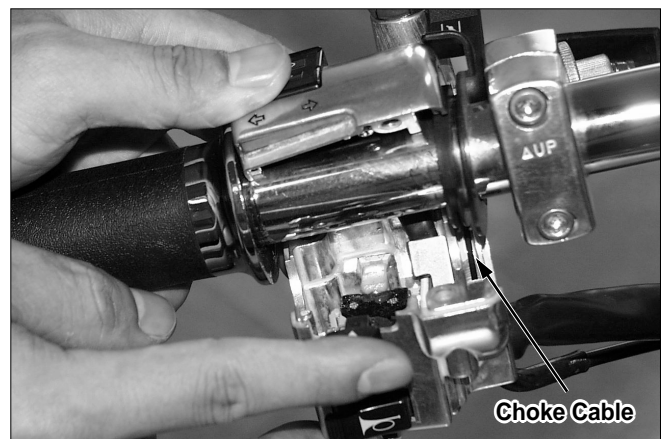

## Front Wheel/Front Fork/Steering

- Tighten the forward screws first, then tighten the rear screws.

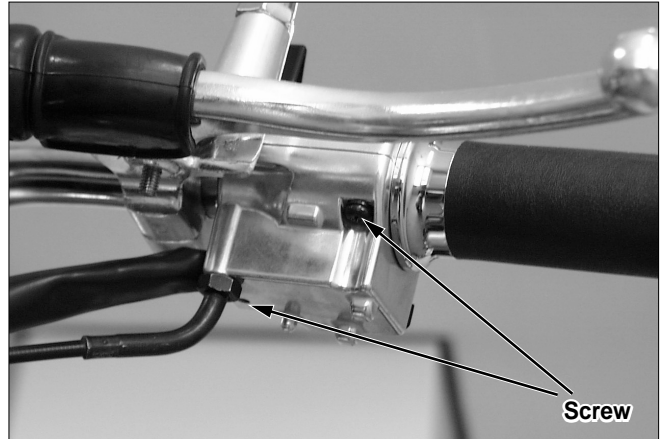

- After installing the brake hose, kill switch cable, winker switch code and chock cable into the cable guide, tighten the guide.



## Front Wheel

### Removal

- Loosen the axle nut.
- Raise and support the motorcycle using a jack. Remove the screw from the speedometer cable. Remove the axle nut, front axle, and front wheel, and right side collar.

#### \* NOTE

- Do not operate the front brake lever after removing the front wheel.

### Inspection

- Inspect the front axle for bent.
- Install the front axle into V-block, and measure it using a dial gauge.  
Service Limit: Over 0.2mm

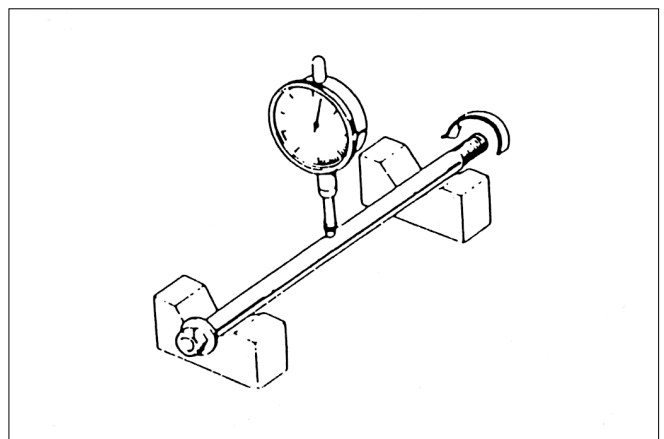
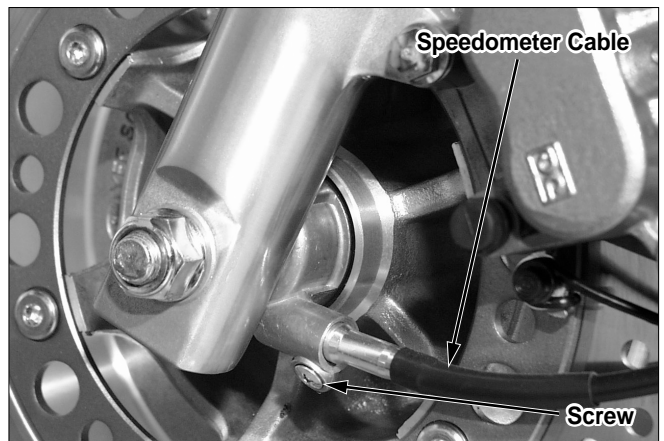

- Check the rim runout by placing the wheel in a truing stand. Spin the wheel slowly and read the runout using a dial indicator.

Service Limit:

Radial Runout: 2.0mm(0.08in)

Axial Runout: 2.0mm(0.08in)

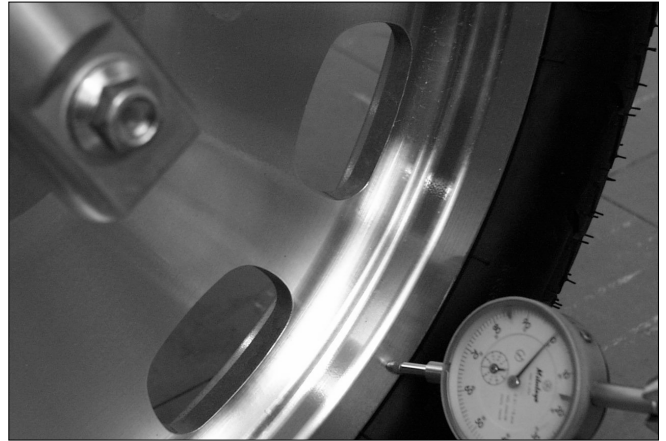

### Wheel Bearing Inspection

- Turn the inner race of each bearing with your finger. The bearings should turn smoothly and quietly. Also check that the bearing outer race fits tightly in the hub. Remove and discard the bearings if the races do not turn smoothly, quietly, or if they fit loosely in the hub.

#### \*NOTE

- Replace hub bearings in pairs.

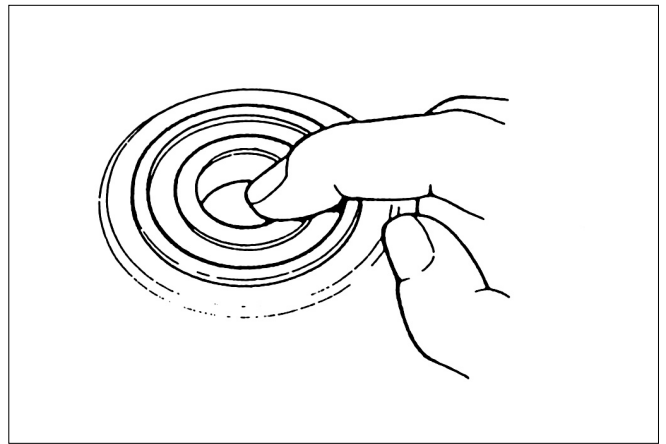

### Removal

- Remove the speedometer gear box, dust seal, speedometer gear retainer.

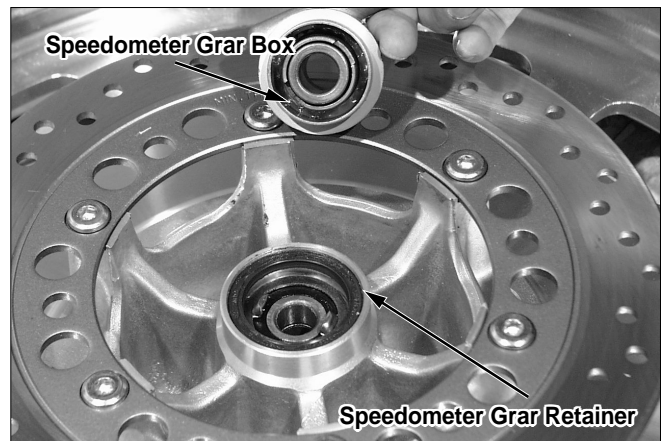

- Remove the right side collar.



## Front Wheel/Front Fork/Steering

- Remove the dust seal of R. side.
- Remove the brake disc of L. side.

### \* NOTE

- Inspection for the problems of disk.  
(⇒Section 15-6)



## Wheel Bearing Replacement

- Install the bearing remover head and remover shaft into the wheel. Remove the distance collar and drive out other bearing

### \* NOTE

- Replace the bearings in pairs. Never install the old bearing. Once a bearing is removed, it must be replaced with a new one.

Tools:

Bearing remover head  
Bearing remover



- Apply grease to the bearing.
- With the bearing seal facing outside, drive the right bearing into the wheel securely, until it is seated.
- Do not allow the bearings to tilt while driving them in. Install the distance collar with the bearing seal surface facing outside and drive a new left bearing in securely until it is seated.

Tools:

Driver  
Attachment, 32 × 35mm  
Pilot, 15mm



## Speedometer Gear Replacement

- Remove the speedometer gear and washer from the speedometer gear box.
- Check the gear for wear and damage.
- Install the washer.
- Coat the speedometer gear with grease and install it.

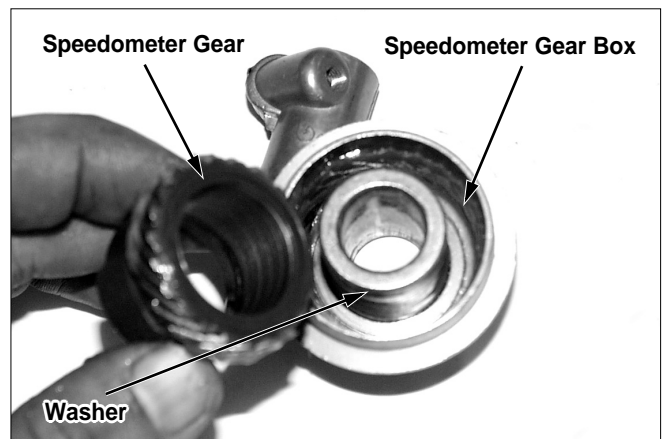

Assembly

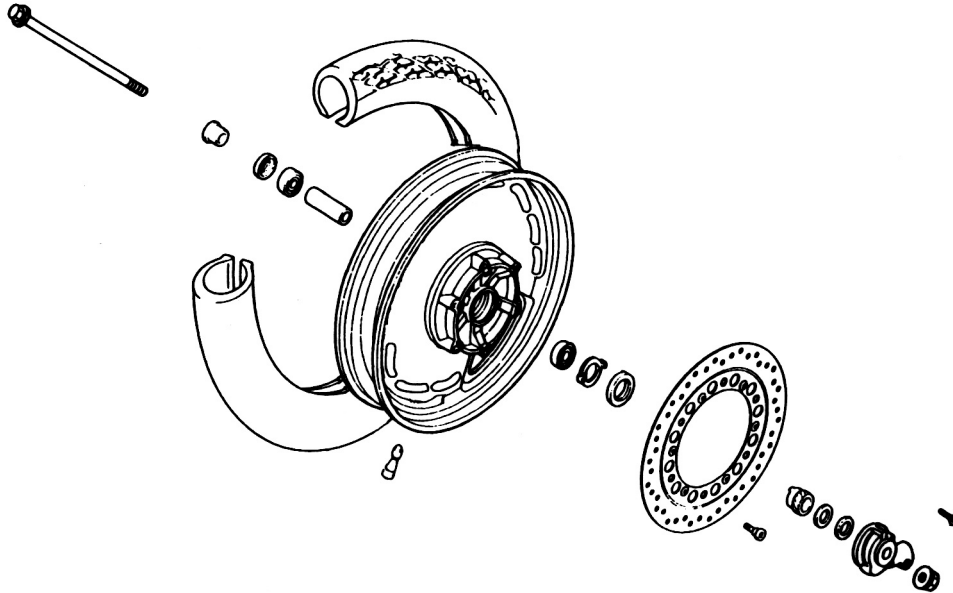

- Apply grease to the dust seal rim.
- Install the dust seal, brake disk.
- Install the brake disk.  
Torque: 4.2kgf-m(42N.m)



Dust Seal

- Install the right side collar.

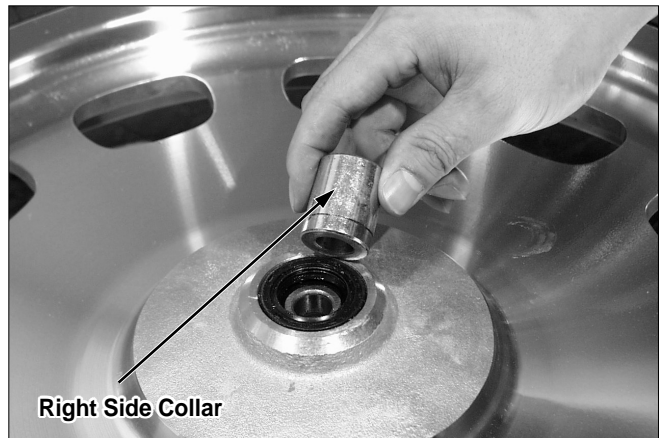

Right Side Collar



## Front Wheel/Front Fork/Steering

- Loosen the brake disc by the disk bolt.
- Align the speedometer gear retainer hole with the slot of the wheel hub.



- Apply grease the dust seal rim. Install the dust seal.
- Install the speedometer box, aligning the tangs in the speedometer gear retainer with the slot in the gear.

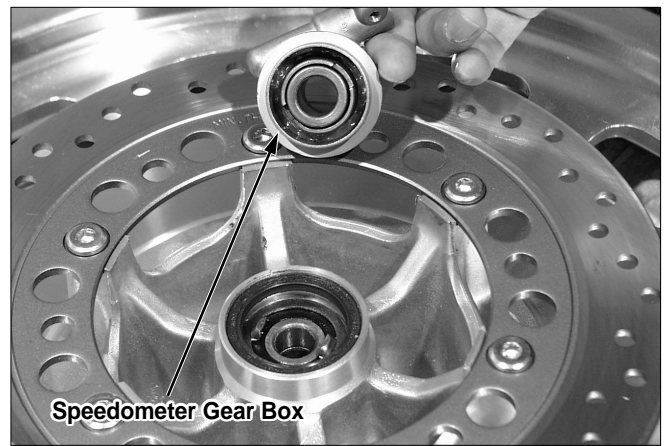

### Assembly

- Place the front wheel between the front fork legs.
- Install the wheel while inserting the brake disk.
- Take care not to damage the brake pads.
- Align the tangs in the left fork slider with the slot the speedometer gear box.
- Install the front axle into the speedometer gear box and wheel hub.

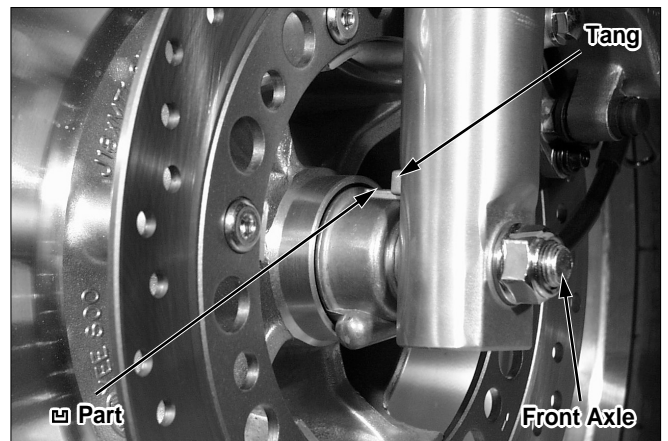

- Screw the axle nut. (U-nut)
- Install the speedometer cable and set screw securely.
- Place the front wheel on the ground, tighten the axle nut with the specified torque.  
Torque: 5.9kgf-m(59N.m)

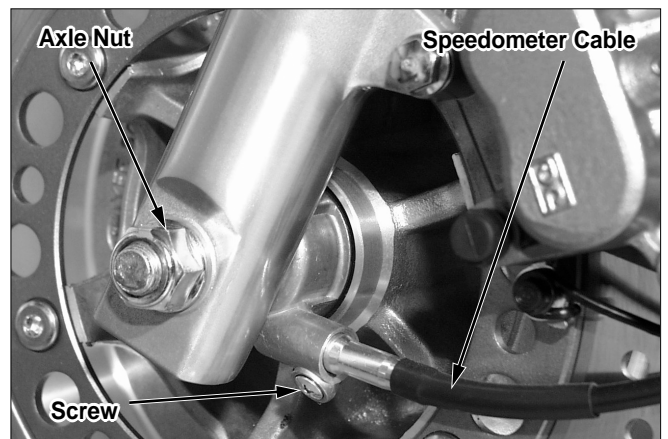

## Front Fork

### Removal

- Remove the following
  - Front wheel (⇒13-6)
  - Brake caliper
  - Front fender

- Loosen the fork tube cap bolt when disassembling the front fork.

**\*NOTE**

- Don't remove the fork tube cap bolt, but loosen it.
- Loosen the fork top socket bolt.
- Loosen the steering stem pinch flange bolt.
- Loosen the front fender pinch socket bolt.
- Remove the front fork.
- Loosen the fork bottom bolt, and remove the fork tube.

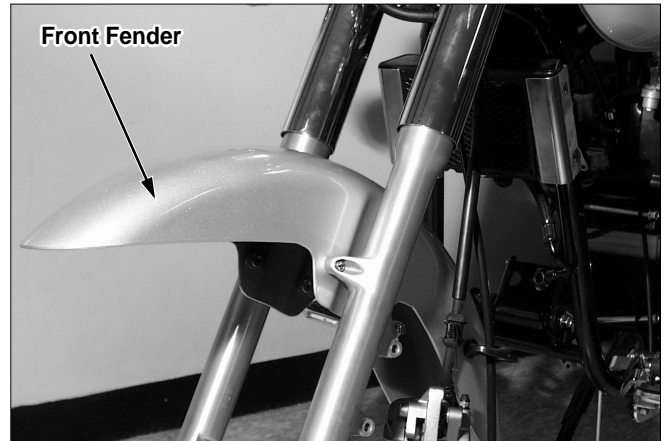

### Disassembly

- Remove the fork tube cap bolt.

**⚠CAUTION**

- If the screw is loosened completely, be careful that the fork tube cap bounds well by the power of spring.
- Remove the fork spring and put out the fork oil by expanding and contracting fork pipe several times.

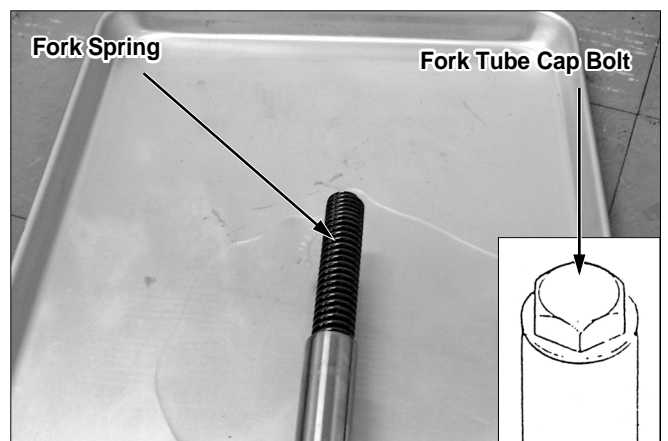

## Front Wheel/Front Fork/Steering

- Cover the bottom case with cloth, and remove the socket bolt.

### ⚠CAUTION

- If not removing the socket bolt with turning, assemble temporarily the spring and fork tube cap bolt.
- Support the bottom case by vise strongly, preventing it from transformation or damaging.

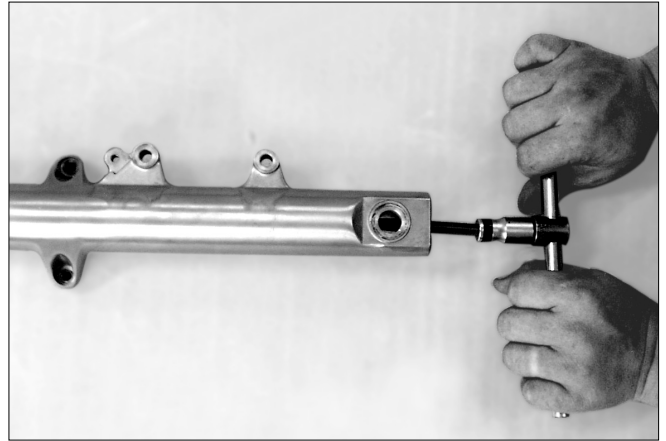

- Remove the fork tube from the bottom case.

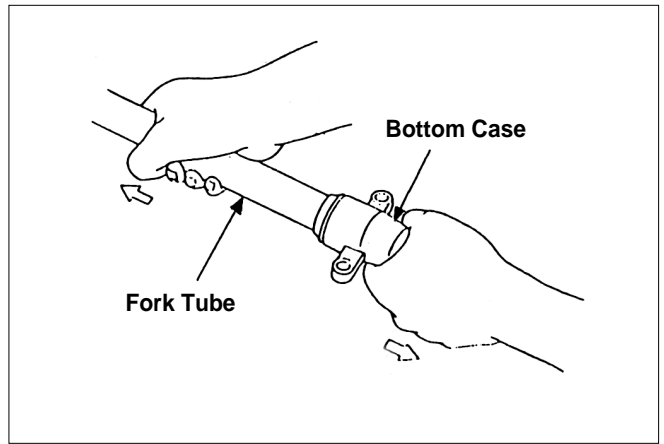

- Remove the oil lock piece.
- Remove the piston, rebound spring from fork tube.

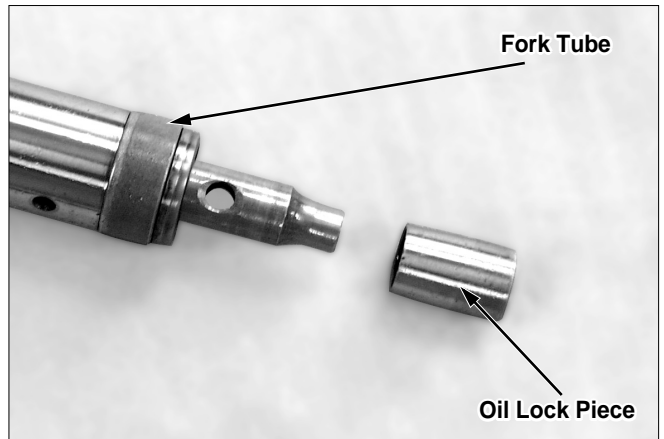

- Remove the dust Seal.

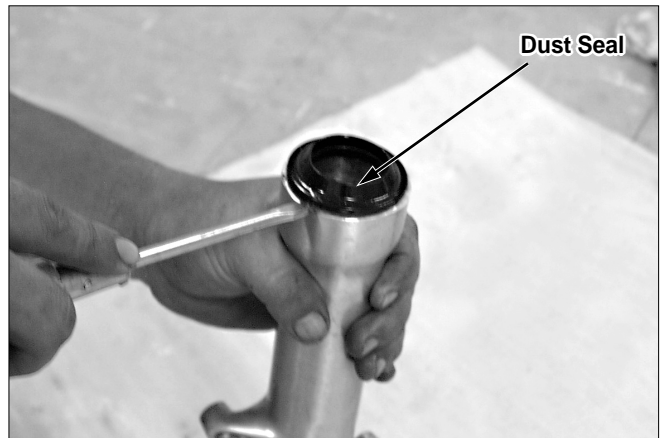

- Remove the set ring.

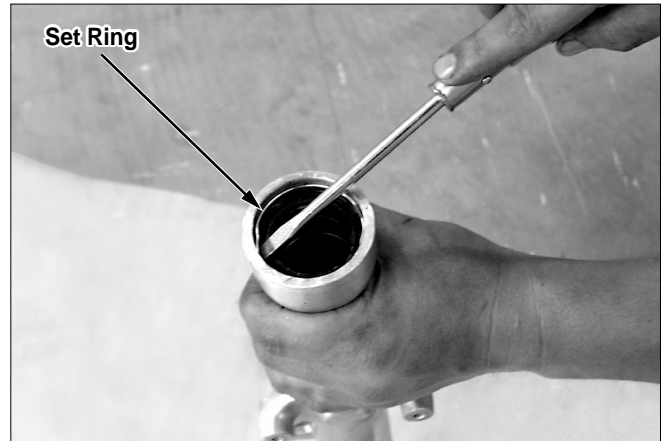

- Remove the oil seal.

**CAUTION**

- Prevent the around of bottom case inside and outside from damaging.



**Inspection**

- Place the fork spring in flat place, and measure the fork spring free length.
- Replace the new one if it is under the service limit.

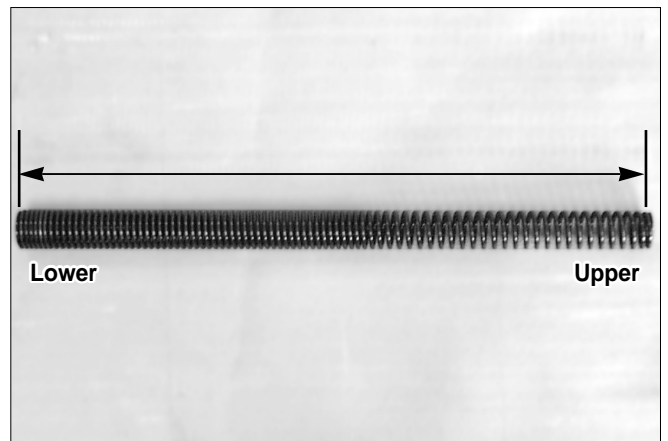

- Inspect each part for damaging and wear, and then must be replaced if necessary.

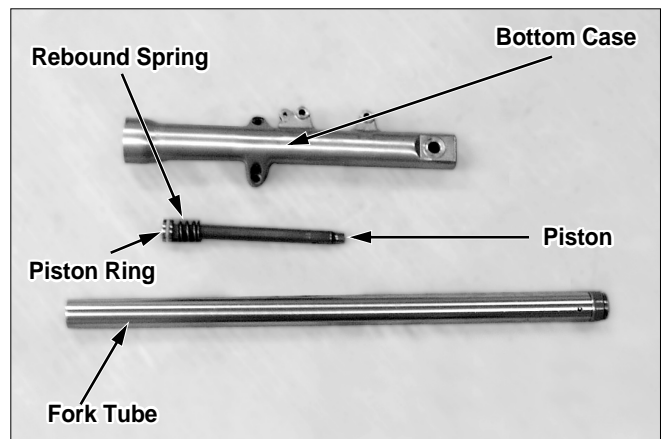

## Front Wheel/Front Fork/Steering

- Install the fork tube into V-block, and measure the bent with a dial gauge.  
Service Limit: replacement if over 0.2mm

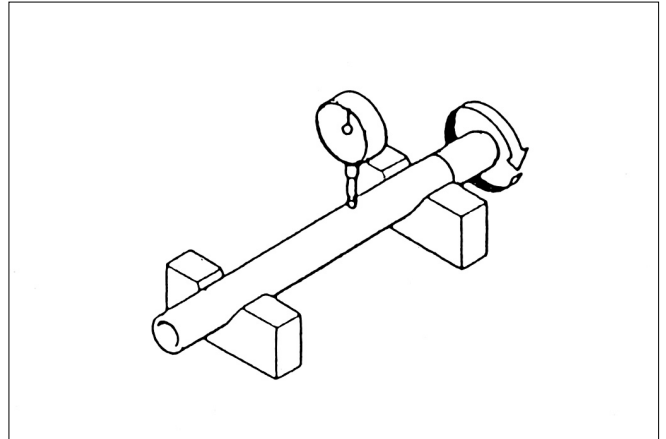

- Inspect the contacted part of slider bush. Bottom case must be replaced if the copper portion is shown over three of quarter in teflon coating part or remarkably damaging.

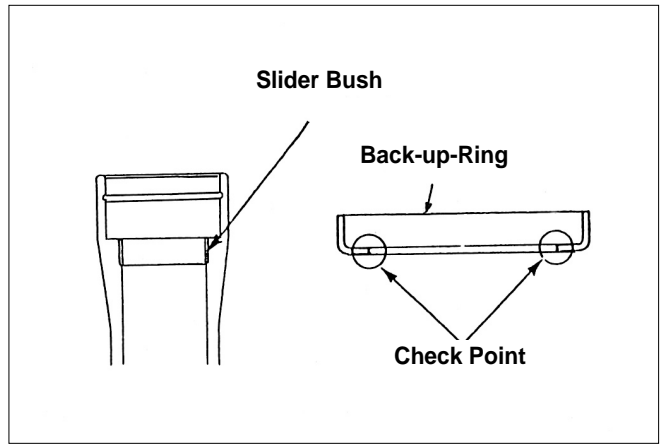

## Assembly

- Before installing, clean each part with clean oil.

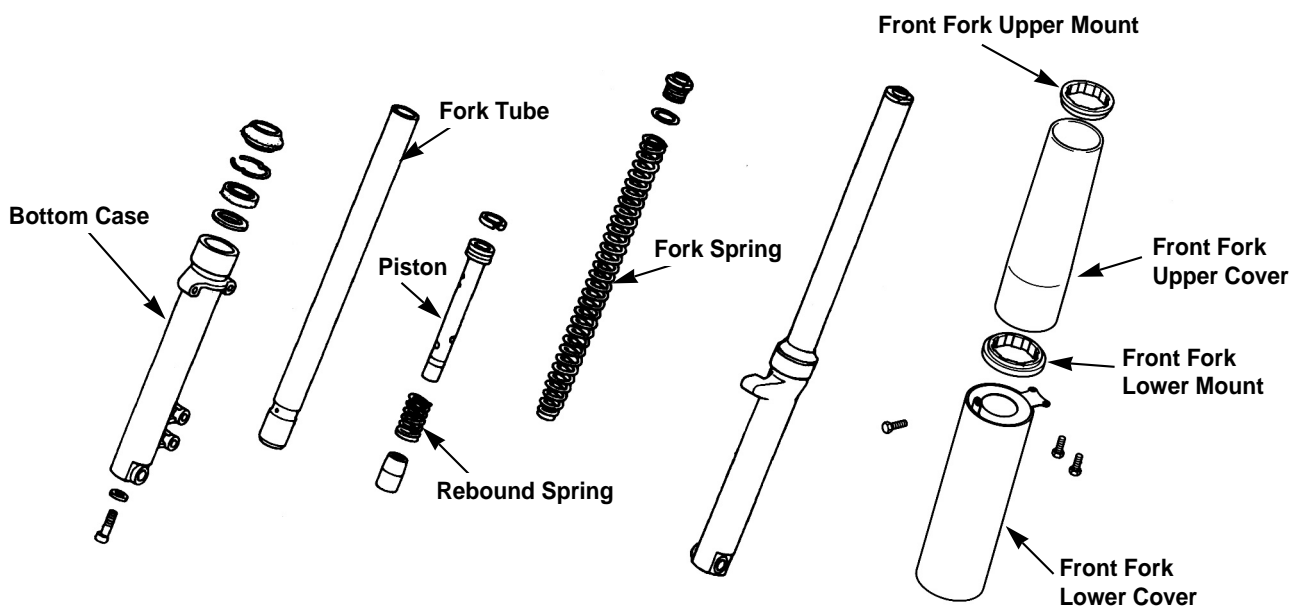

- Connect the rebound spring and fork piston into the fork tube.
- Connect the oil lock piece into the piston top end part, and install the fork tube into the bottom case.

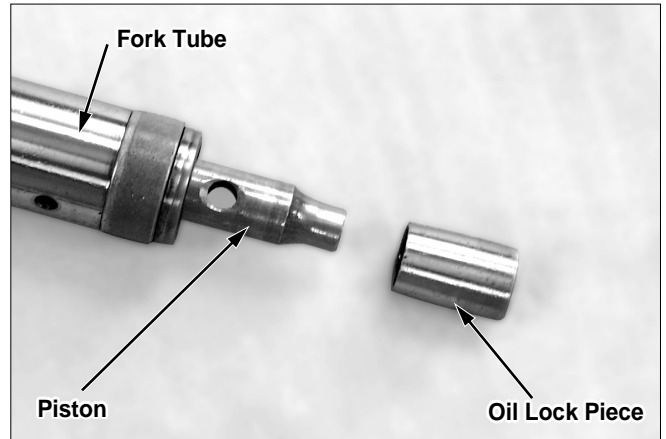

- Cover the bottom case with cloth, and fix it into the vise.
- Coat the bolt part of socket bolt with oil to the tread, and install the fork piece.  
Torque: 2.0kg-m

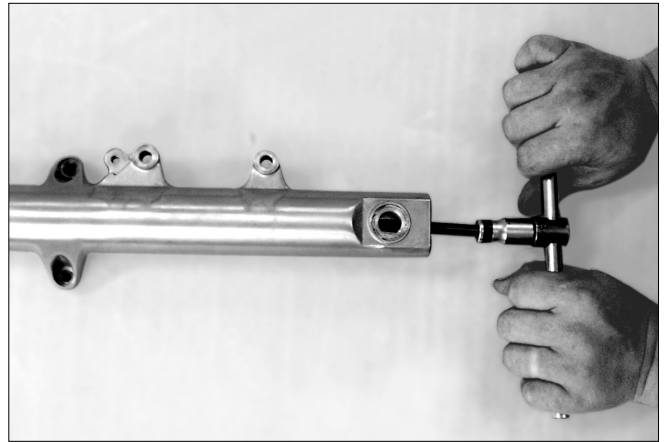

### ⚠ CAUTION

- When fixing the bottom case to the vise, insert the bracket part avoiding the case from putting into it directly.
- Install the back-up ring.

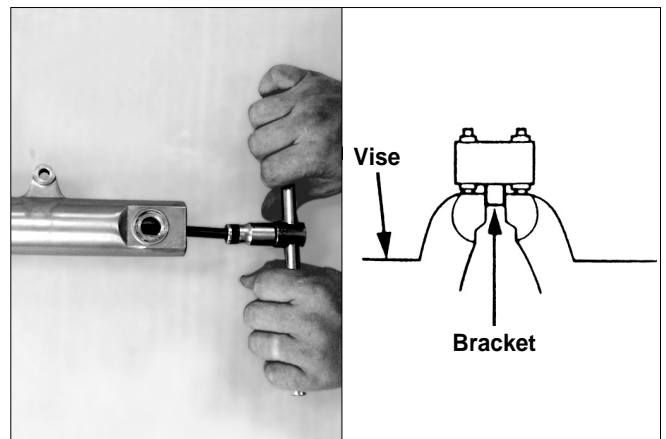

- Coat the ATF with the new oil seal.
- Insert the oil seal until showing the assembling groove of bottom case set ring using the tools.

Tools:

- Fork seal driver
- Fork seal driver body

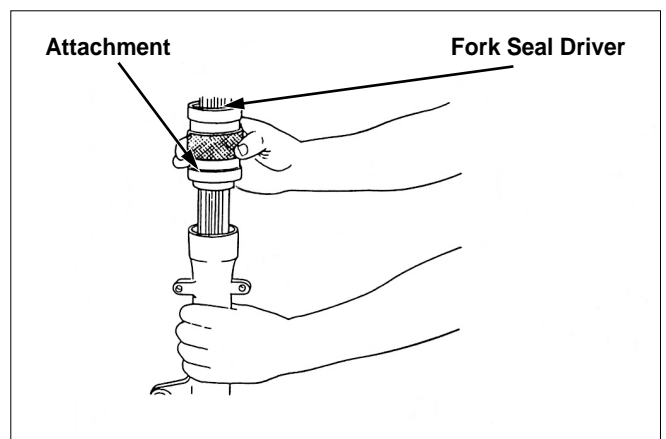

## Front Wheel/Front Fork/Steering

- Install the set ring.
- Install the set ring to bottom case exactly.

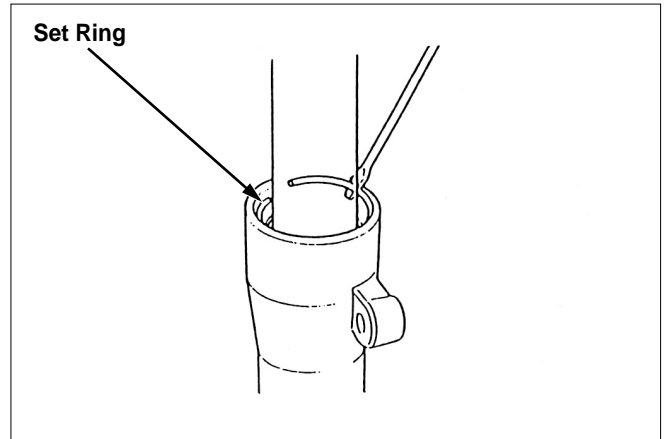

- Install the dust seal.

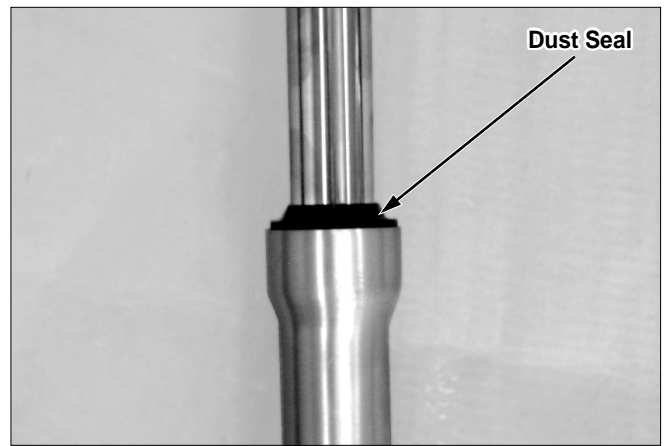

- Fill the auto-transmission fluid (AFT) into the fork tube according to standard amount.  
Capacity: 280cm<sup>3</sup>
- Pull out the air by pressing the fork tube 2-3 times slowly.
- Check the oil level in state of compression.  
Oil Level: 250mm

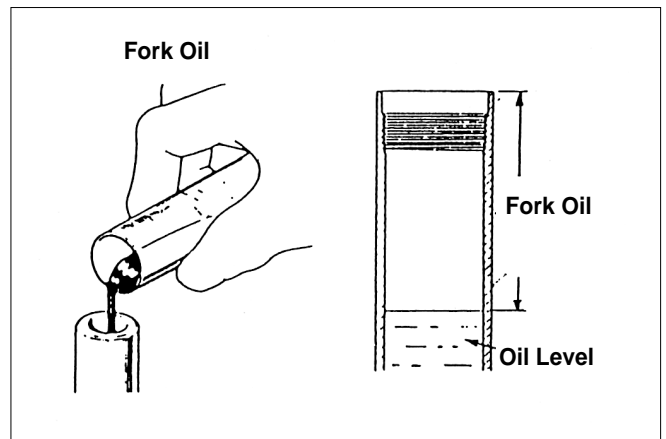

- Install the spring into the fork tube.

### **CAUTION**

- Make a spring face down the small side of pitch.

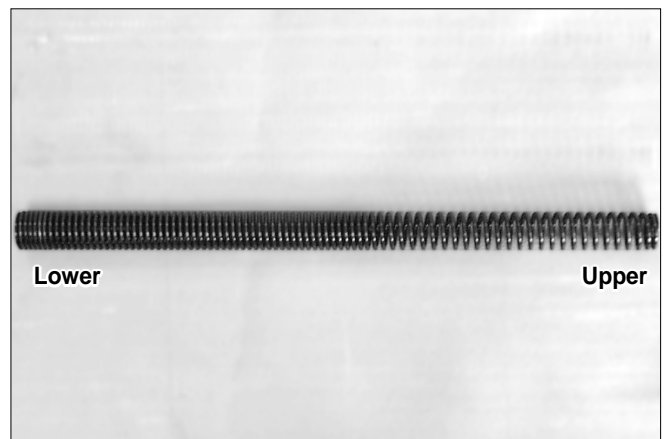

- Install the new O-ring to fork tube cap bolt.

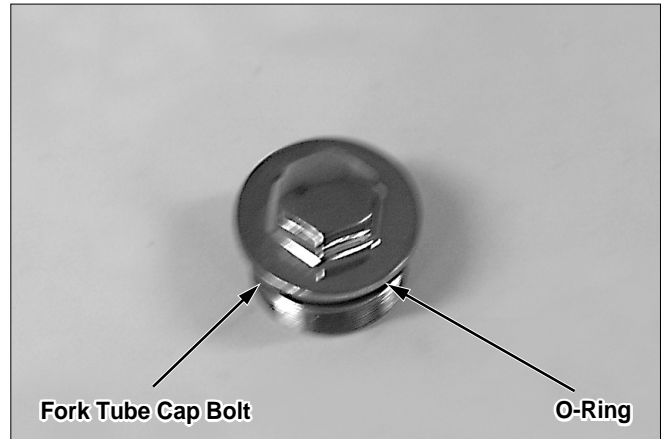

- Install the fork tube cap bolt to fork tube.

**CAUTION**

- Do not install the fork tube cap bolt again.

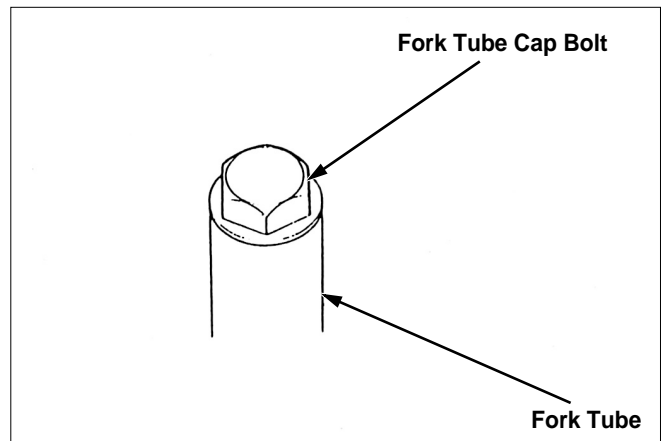

**Installation**

- Install the front fork into the steering stem, top bridge.
- Align the top end of the fork tube with the upper surface of the top bridge.
- Install the fork top socket bolt.  
Torque: 2.0kgf-m



- Install the fork bottom pinch bolt.  
Torque: 3.3kgf-m

**\* NOTE**

- Be care that the collar is not to separate.





## Front Wheel/Front Fork/Steering

- Install the following:
  - Brake Caliper
  - Torque: 3.0kgf-m
  - Front fender
  - Front wheel (⇒13-6)

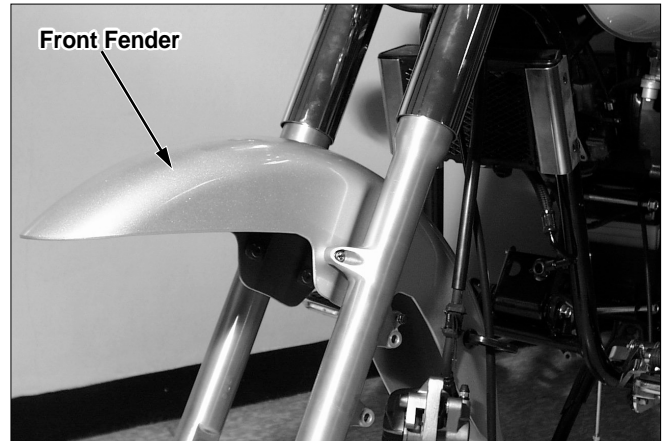

## Steering Stem

### Removal

- Remove the parts as following.
  - Handle (⇒13-3)
  - Remove the cable guide.
  - Front wheel (⇒13-6)
  - Front fender
  - Brake caliper
  - Front fork and fork lower cover
  - Front emblem stay
- Remove the head light.
- Remove the brake hose clamp.
- Remove the steering stem nut washer.
- Remove the top bridge.

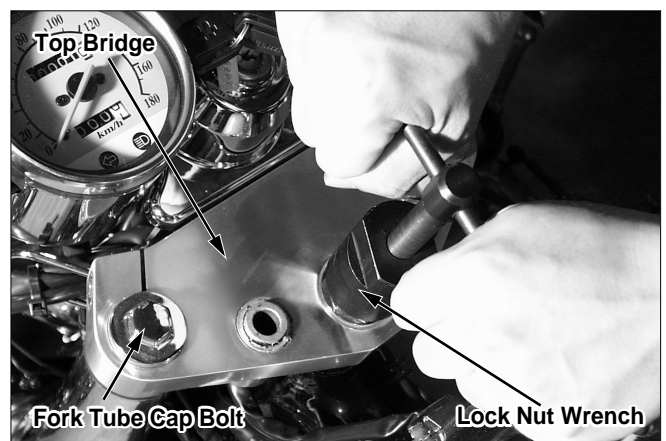
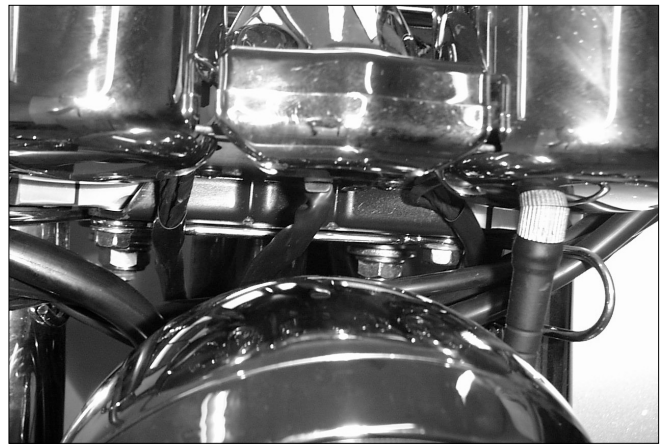

- Remove the steering head top thread.

Tools:

- Steering stem socket
- Extension bar

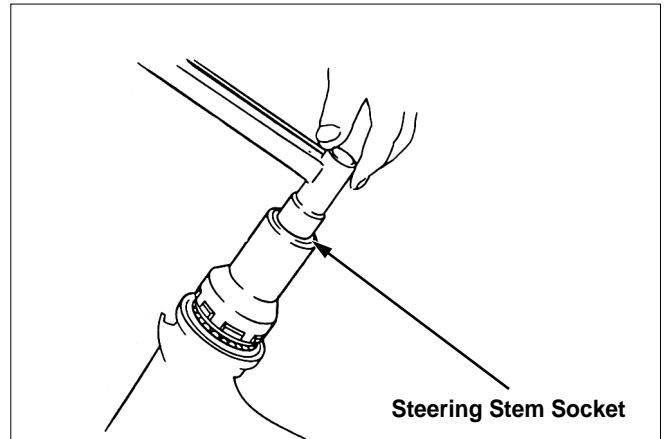

- Remove the steering upper bearing.

**\* NOTE**



### Bearing Replacement

**\* NOTE**

- Always replace the bearing and races as a set.

Tool: Ball race driver

- To protect the nuts, install the stem nut into the steering stem and remove the steering under bearing with a drill or equivalent tool. Be careful not to damage the stem.

Dust Seal: Remove the washer.

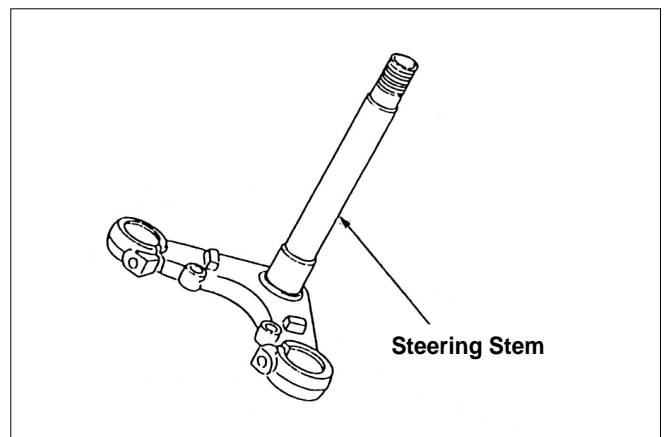

## Front Wheel/Front Fork/Steering

### \* NOTE

- If the motorcycle had caused an accident, check the steering head pipe for crack or damage.

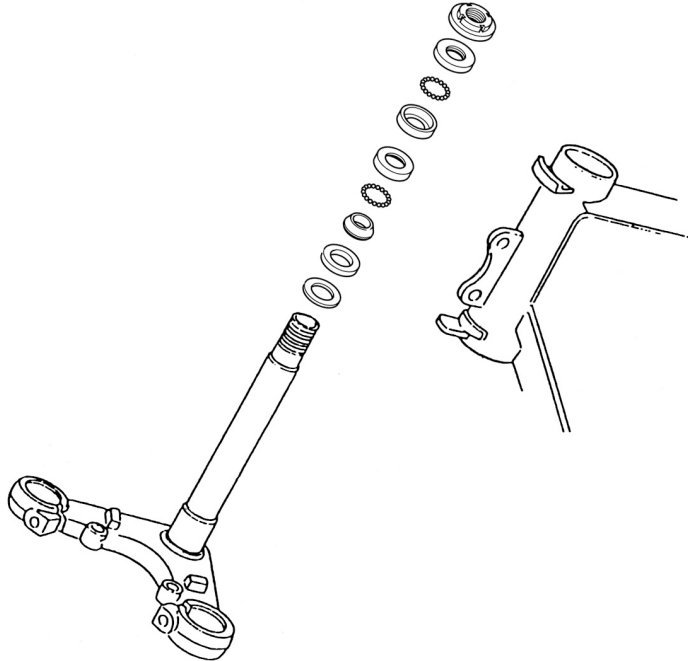

- Tighten the top thread.

Torque: 1.8kgf

Tools:

Steering stem socket

Extension bar

- Move the steering stem from side to side 4-5 times, and allow the steel ball to operate.
- Loosen the top thread, and tighten the final torque again.

Torque: Thread 0.3kgf-m

- Install the top bridge washer steering stem nut.
  - After installing R.L front fork temporarily, install the steering stem nut and tighten it.
- Torque: 7.0kgf-m

Tools:

Lock nut wrench 30 × 32mm

Extension bar

- After arranging the cable, install the cable guide.
- Install the front fork. (⇒13-11)

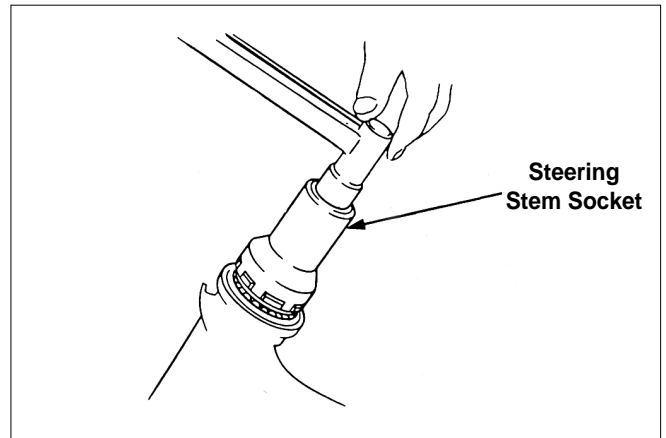

- After arranging the cable, install the cable guide.
- Install the front fork. (⇒13-11)



- Install the parts as the below.
  - Head light
  - Front emblem stay
  - Brake caliper
  - Front fender
  - Front wheel (⇒13-6)
  - Cable guide and combimeter
  - Handle (⇒13-3)



## Rear Wheel/Rear Brake/Suspension

---

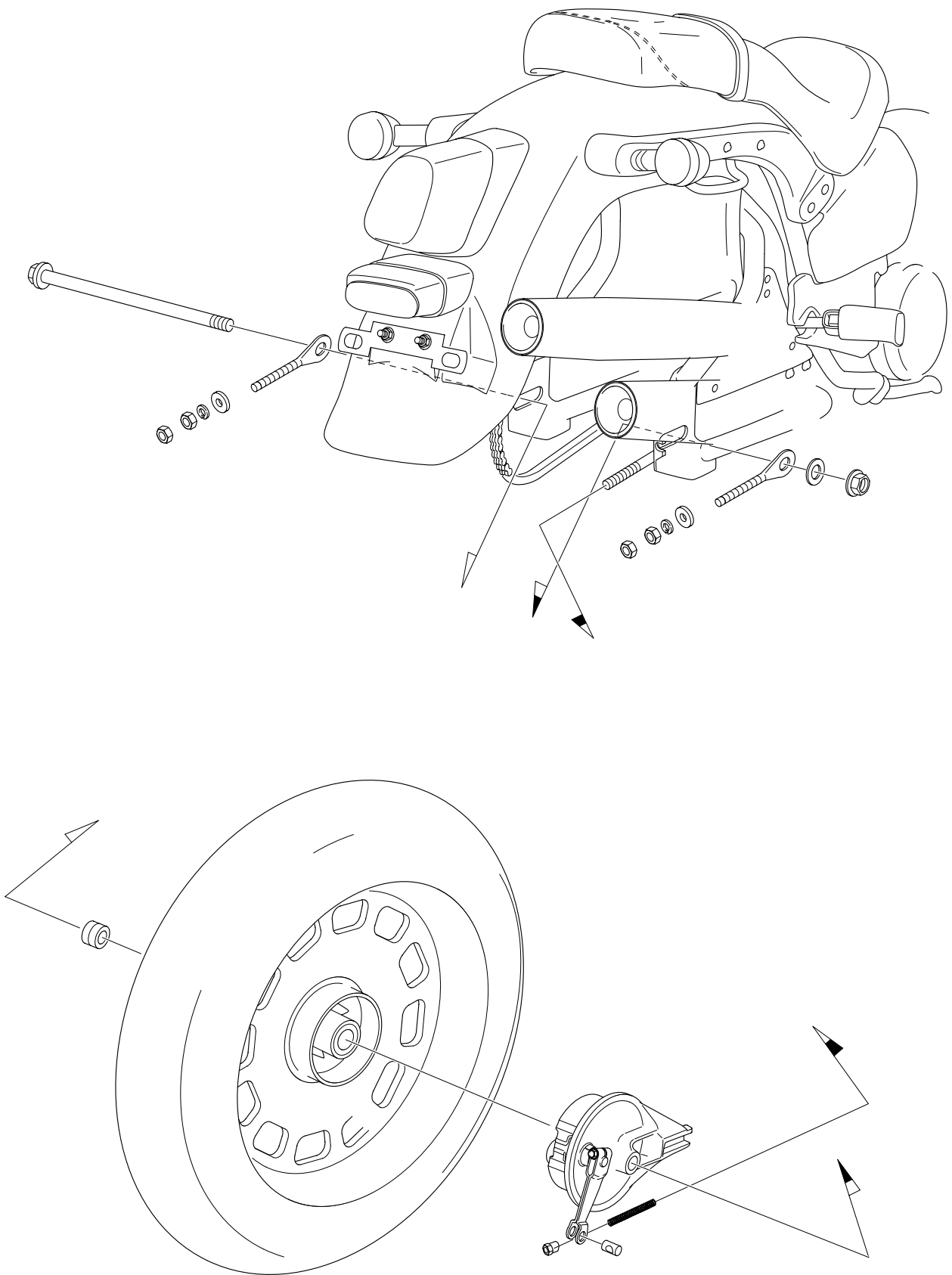

## 14. Rear Wheel/Rear Brake/Suspension

Service Information .....	14-1	Rear Brake Pedal.....	14-8
Troubleshooting .....	14-2	Rear Cushion .....	14-8
Rear Wheel .....	14-3	Rear Fork .....	14-10
Rear Brake .....	14-6		

### Service Information

#### General

- Note the assembling direction of the bolts.

#### Specifications

Unit: mm(in)

Item		Standard	Service Limit
Axle shaft runout		——	0.2(0.008)
Rear wheel rim runout	Radial	——	2.0(0.08)
	Axial	——	2.0(0.08)
Rear brake drum I.D.		130(5.12)	131(5.16)
Rear brake lining thickness		4.0(0.16)	2.0(0.08)
Rear Cushion Spring Free Length		206.7	

#### Torque Values

Rear Brake Arm Bolt	1.0kgf-m
Rear Axle Nut	8.8kgf-m
Rear Shock Absorber Mounting Upper Bolt	3.4kgf-m
Rear Shock Absorber Mounting Lower Bolt	3.4kgf-m
Rear Fork Pivot Bolt	4.5kgf-m
Final Driven Sprocket Nut	5.9kgf-m

### Tools

Common

Rear Cushion Compressor

Rear Cushion Compressor Attachment

Attachment, 32 × 35mm

Attachment, 42 × 47mm

Pilot, 15mm

Driver

Bearing Remover Shaft

Remover Head, 15mm

## Troubleshooting

### Wobble or vibration in motorcycle

- Bent rim
- Worn rear wheel bearings
- Faulty tire
- Loose axle
- Incorrect tire pressure
- Worn rear fork bush

### Soft suspension

- Weak spring
- Incorrect rear cushion adjuster
- Faulty rear damper

### Hard suspension

- Incorrect rear shock absorber adjuster
- Bent damper rod

### Rear cushion noise

- Binding shock case
- Loose fasteners

### Weak brake power

- Incorrect brake adjustment
- Damaged brake shoe surface
- Worn brake shoe cam
- Worn brake
- Worn brake drum
- Incorrect brake arm adjusting place

## Rear Wheel

### Removal

- Raise and support the motorcycle with main stand.
- Loosen the rear brake adjuster, remove the brake rod.
- Loosen the chain adjusting nut.
- Remove the axle nut, then disconnect the axle shaft.
- Remove the drive chain by pressing the rear wheel forward.
- Remove the rear wheel.
- Remove the brake pedal.

### Inspection

- Inspect the winding of Axle Shaft.  
Service Limit: 0.2mm
  
- Inspect by the oscillation of rim in turning the wheel.  
Service Limit: Radial: 2.0mm (0.008in)  
Axial: 2.0mm (0.008in)
  
- Replace the worn bearing by turning the bearing.

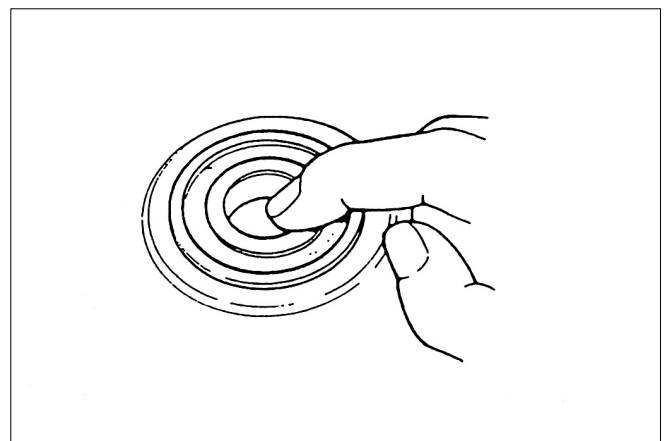
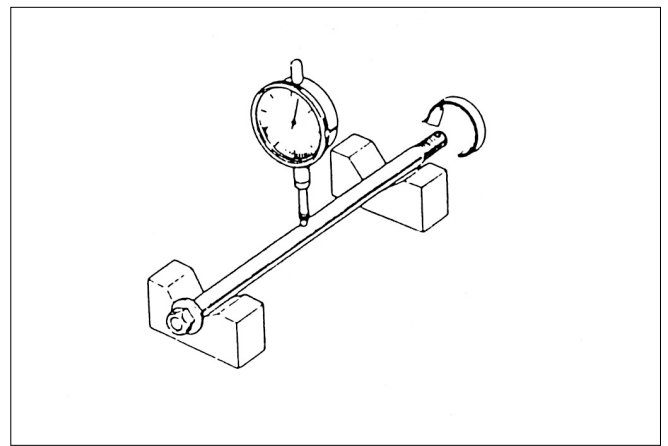



## Rear Wheel/Rear Brake/Suspension

- Check the teeth of the final driven sprocket.
- Replace the worn, damaged final driven sprocket.

### **⚠ WARNING**

- Check the drive chain and drive sprocket at the same time.

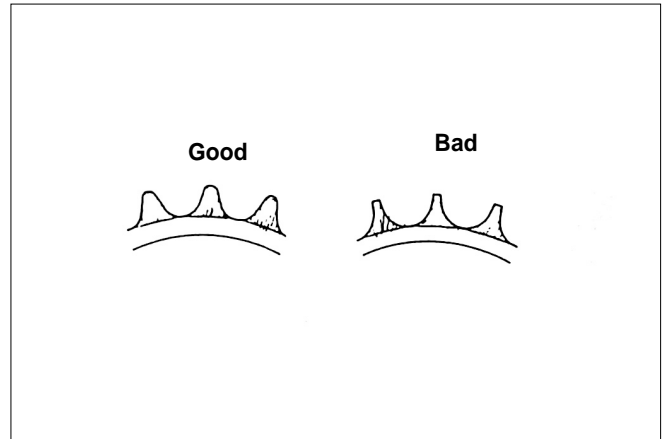

## Disassembly

- Remove the snap ring and final driven sprocket.

### **\* NOTE**

- Do not disassemble unless replacement.

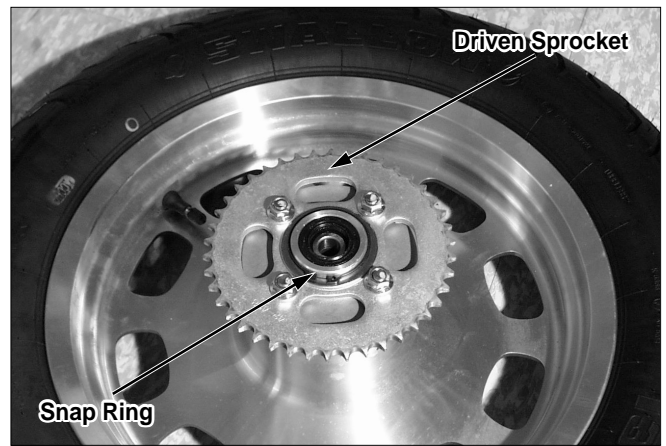

- Check the damper rubber. Replace the faulty, damaged, worn damper rubber.
- Remove the dust seal if it is damaged.



## Bearing Replacement

- Install the bearing remover into the bearing.
- Install the bearing remover shaft at the opposite position, and remove the wheel bearing by heating with a hammer.
- After removing the distance collar, remove the other bearing.

### **\* NOTE**

- When taking off the wheel bearing, must be replaced with the new one.

Tools:

- Bearing remover shaft
- Remover head



- Coat the bearing with the grease.
- Insert the new bearing in parallel with the seal side facing outside. After inserting the distance collar, insert the bearing of the right side with the seal side facing outside.

Tools:

- Driver
- Attachment
- Pilot, 15mm



### Assembly

- Install the dust seal after applying the grease.
- If the damper rubber was removed, install the damper rubber.

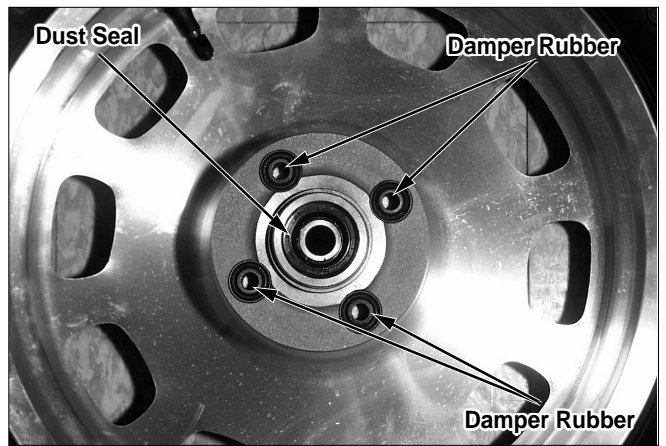

- Make the part in protection ring face the outside, and connect the final driven sprocket. Install the snap ring into the groove exactly.

#### \* NOTE

- Install the snap ring into the groove exactly.
- If the driven sprocket nut was removed, install the nut after aligning the flange part of fixing bolt with the sprocket inside groove.  
Torque: 5.9kgf-m(59N.m)
- Attach the side collar.



### Installation

- Install the brake panel into the rear wheel.
- Align the rear fork steeper with the slot of the brake panel.
- Install the drive chain into the sprocket.



## Rear Wheel/Rear Brake/Suspension

- Install the chain adjuster, insert the axle shaft from the left side.
- Install the chain case B.
- Install the brake rod, brake adjusting nut. Check the drive chain operation.
- Install the lock washer and axle nut.  
Torque: 8.8kgf-m
- Adjust the brake pedal operation. (⇒3-11)

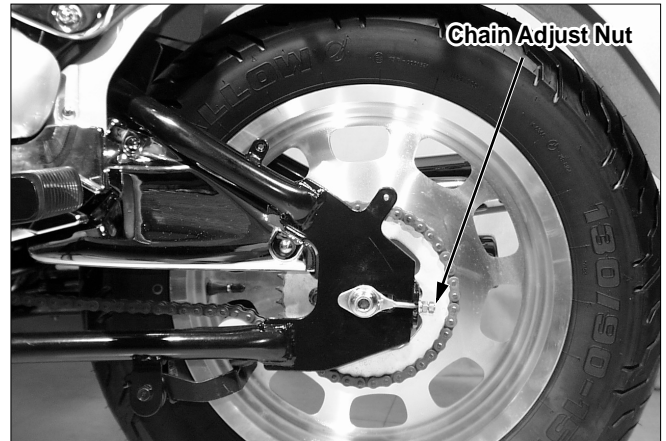

## Rear Brake

### Removal

- Remove the rear wheel. (⇒14-3)
- Remove the brake panel from the rear wheel.



### Inspection

- Measure the brake drum I.D.  
Service Limit: 131mm (5.16in)
- Measure the rear brake lining thickness.  
Service Limit: 2.0mm (0.08in)



### Disassembly

- Open the brake shoe with hands and remove it from the brake panel. Separate the split pin from the washer. Remove the shoe spring from the brake shoe.
- Remove the brake arm, wear indicator, cam dust seal.
- Remove the brake cam.

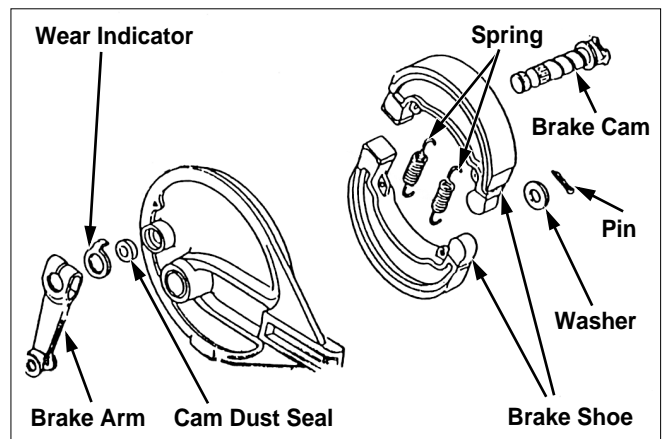

### Assembly

- Apply Grease a little to the anchor pins and brake cam.
- Assemble the brake cam.

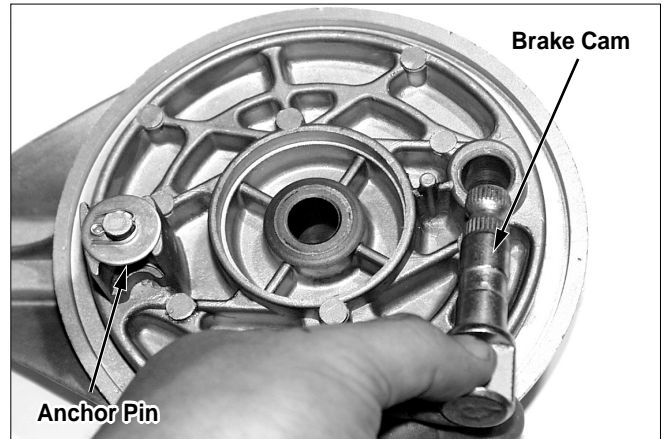

- Apply engine oil the dust seal, install it onto the brake panel. Install the wear indicator, aligning the punch mark on the brake cam with the gap.

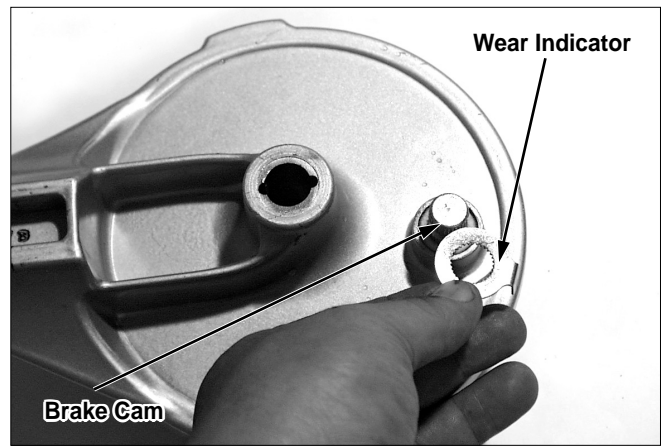

- assemble the brake arm with the punch mark on the brake cam.
- Install the brake arm bolt.  
Torque: 1.0kg-m (10N.m, 7ft-lb)

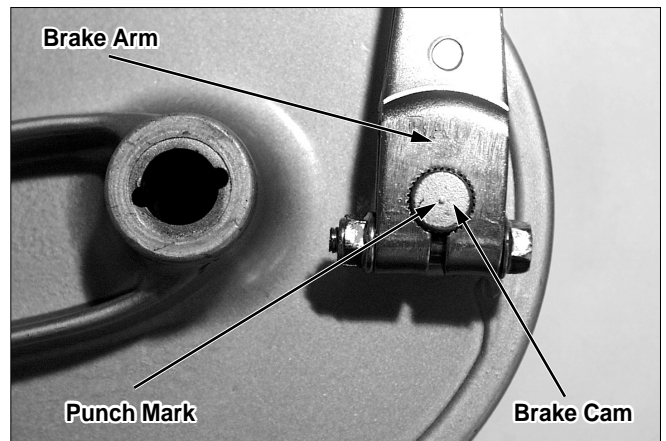

- Assemble the brake shoe and spring.
- Install the washer, a new split pin.

### ⚠ CAUTION

- Keep grease off the brake linings.
- Install the brake panel into the wheel hub and install the rear wheel.

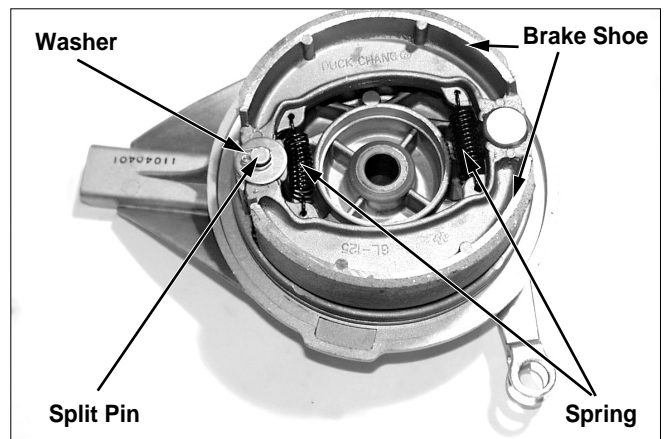

## Rear Brake Pedal

### Disassembly

- Remove the bolts and brake pedal.
- Loosen the rear brake adjusting nut and remove the brake rod from the brake arm.
- Separate the stop switch spring from the return spring.
- Tilt the motorcycle body to the left, remove the pedal pivot shaft by pushing.



### Assembly

- Apply grease to the brake pedal pivot shaft and install it while hooking the stop switch spring and brake return spring.



- Install the brake pedal bolt, aligning the punch mark on the brake pedal with the punch mark on the pivot shaft. Install the brake pedal bolt. Torque: 2.2kgf-m(22N.m)
- Adjust the rear brake free play. Free play: 20~30mm

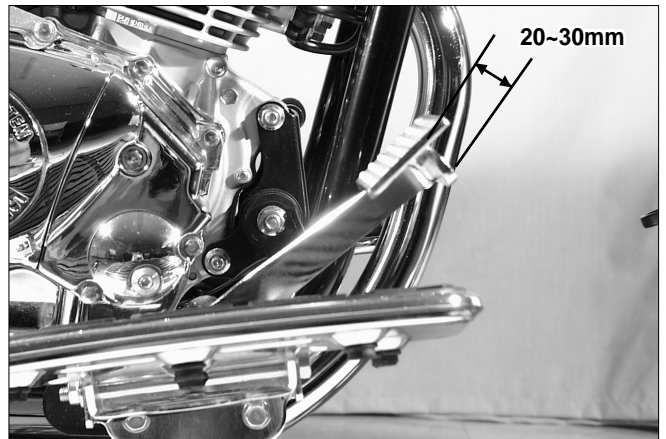

## Rear Cushion (Shock Absorber)

### Removal

- Raise and support the motorcycle with main stand.
- Loosen the rear cushion upper, lower mounting bolts, remove the rear cushion.

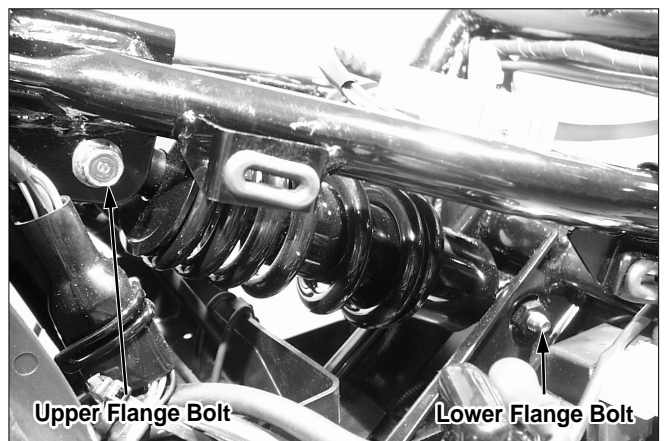

### Disassembly

- Install the rear cushion compressor and attachment.

Tools:

- Rear cushion compressor
- Rear cushion attachment

#### ⚠ CAUTION

- Avoid the upper joint from damage.

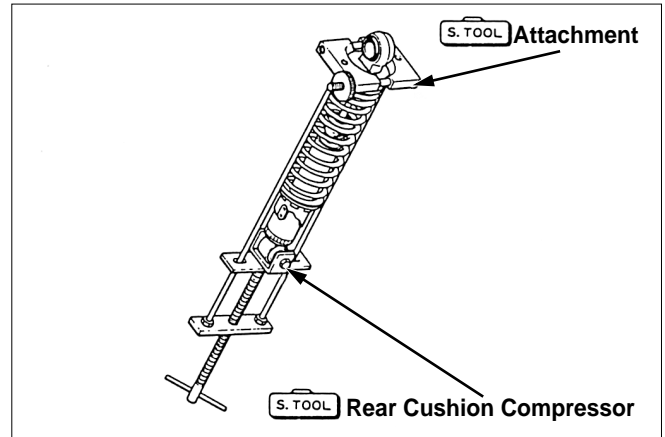

- Fix the upper joint, and remove the upper joint by loosening the lock nut.
- Remove the case, spring, lock nut, damper rubber, and spring adjuster.

#### ⚠ CAUTION

- Be careful when dismantling because of the strong tension of spring

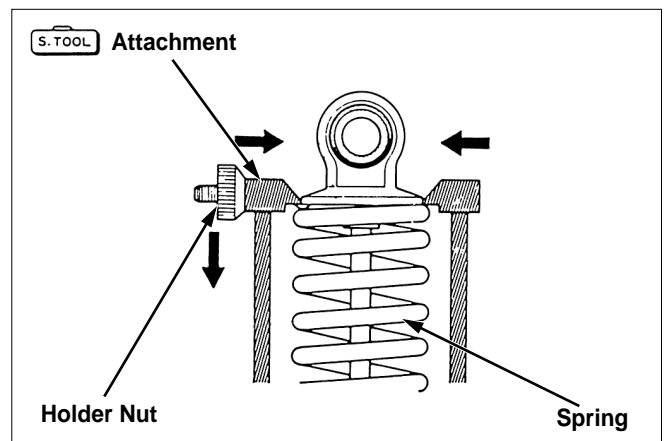

### Inspection

- Measure the free length of rear cushion spring.
- Inspect the damper rod for winding and damaging.
- Inspect the damper unit for oil leakage.
- Inspect the damper rubber for damaging and crank.

#### ⚠ CAUTION

- Never dismantle and heat damper unit.

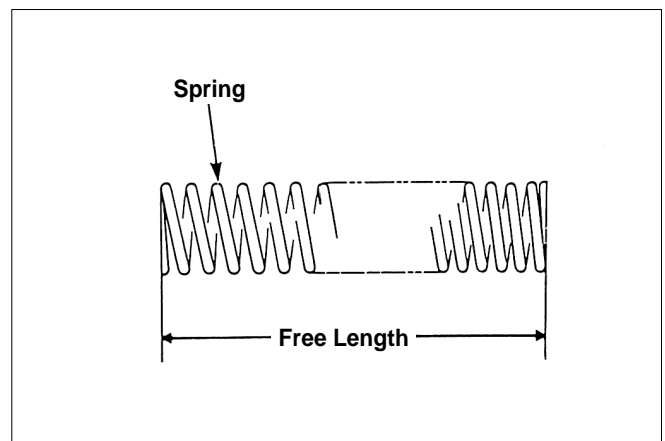

### Assembly

- Install the spring adjuster and damper rubber.
- Assembly is done in the reverse order of disassembly.

#### \*NOTE

- Install the rear cushion spring making the small position of pitch face up.

## Rear Wheel/Rear Brake/Suspension

---

- Coat the lock nut with oil to the thread, and install the rear cushion compressor attachment into the damper rod.
- Coat the upper joint with oil to the thread and install it into the damper rod.
- Fix the upper joint and tighten the lock nut.  
Torque: 3.8kgf-m (38N.m)  
Tools:  
Rear cushion compressor  
Rear cushion compressor attachment

### Installation

- Install the rear cushion.
- Install the bolt  
Torque: Upper bolt: 3.4kgf-m  
Lower bolt: 3.4kgf-m



## Rear Fork

### Removal

- Remove the rear wheel. (⇒14-3)
  - Remove the rear cushion. (⇒14-8)
  - Remove the chain cover.
- 
- Loosen the pivot bolt and nut using a box wrench, and remove the rear fork.

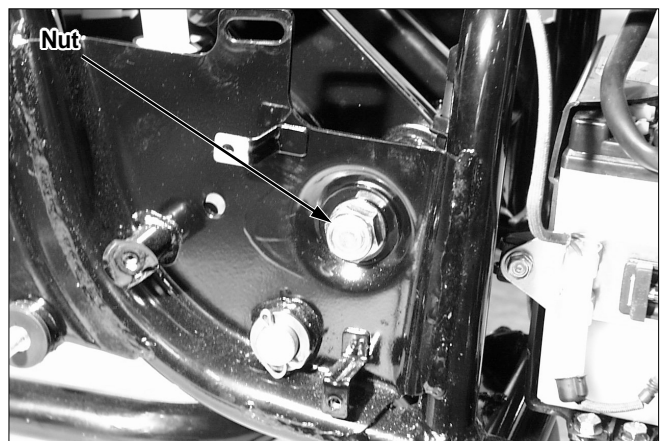

### Disassembly

- Disassemble the rear sub fender.
- Disassemble the chain slider.
- Disassemble the rear fork pivot bearing.
- Disassemble the dust seal and center collar.
- Disassemble the pivot bush.



- Inspect the center collar pivot bush for wear, damage, and defect.
- Check the dust seal for wear and damage.
- Check the rear fork for wear and other damage.
- Inspect the rear pivot fork bearing for wear or damage if necessary replaced.

### Assembly

- Apply grease to the center collar, pivot bush, and install them to the rear fork.

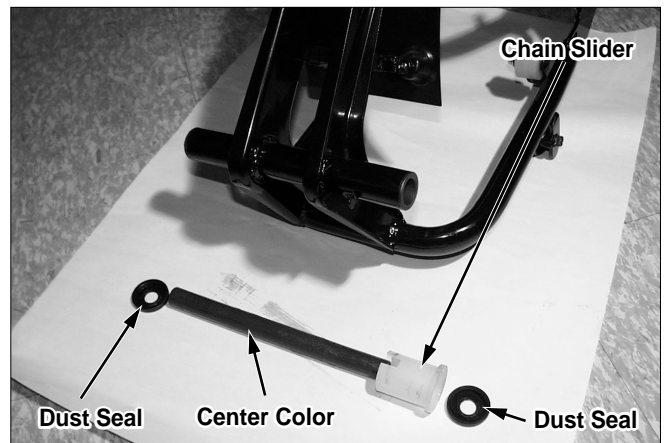

- Assemble the chain slider.
- Coat the dust seal lips with grease, and install it.
- Assemble the rear sub fender.

#### **CAUTION**

- Assemble carefully not to bend or damage the sides of the seal.



### Installation

- Install the rear fork and tighten the pivot bolt.  
Torque: 4.5kgf-m
- Install the following.
  - Rear cushion
  - Chain cover.
  - Rear wheel
  - R/L lower cover





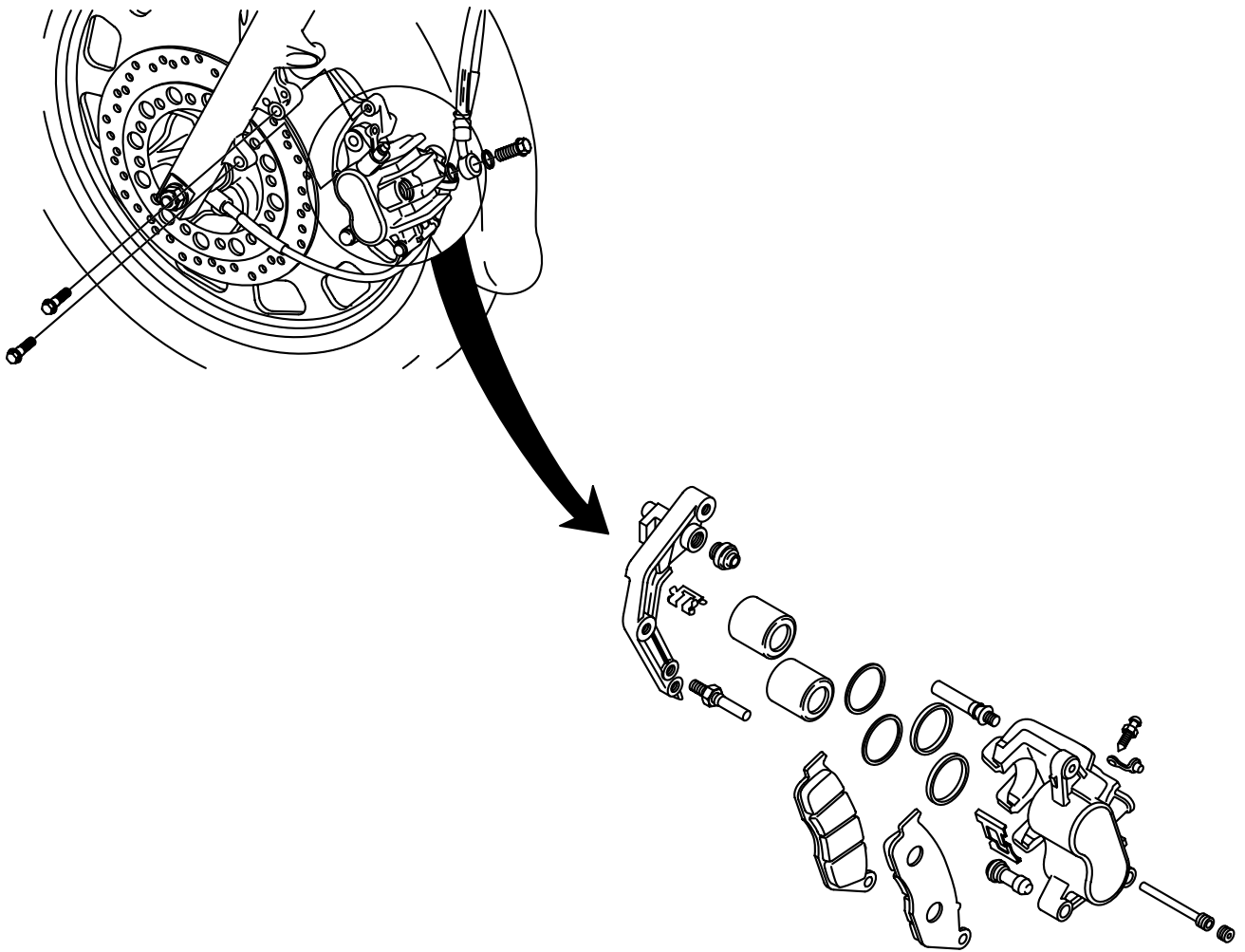

## 15. Hydraulic Brake

<b>Service Information</b> .....	<b>15-1</b>	<b>Brake Disk</b> .....	<b>15-6</b>
<b>Troubleshooting</b> .....	<b>15-2</b>	<b>Brake Caliper</b> .....	<b>15-7</b>
<b>Brake Fluid/Bleeding</b> .....	<b>15-3</b>	<b>Master Cylinder</b> .....	<b>15-9</b>
<b>Brake Pad</b> .....	<b>15-4</b>		

### Service Information

#### General

- Do not allow foreign material to enter the system when filling the reservoir.
- Do not mix different types of brake fluid. They are not compatible.
- Do not use removed brake fluid again.
- Brake fluid can cause damage to painted, plastic, and rubber surfaces. Place a rag over these parts whenever the system is served.
- Cover the hose joint part to prevent brake fluid leakage.
- Clean the removed parts with brake fluid, check for the clogged passage with compressed air.
- Do not allow dust and dirt to stick to the removed parts.
- Install the parts after clean.
- Replace the specified parts.
- The brake pads can be removed without disconnecting the hydraulic system.
- Bleed the hydraulic system if it has been disassembled.

#### ⚠ CAUTION

- A contaminated brake disk or pad reduces stopping power. Discard contaminated pads and clean the disk with a high quality brake degreasing agent.

#### Specifications

Unit: mm(in)

Item	Standard	Service Limit
Brake Disk Thickness	3.8-4.2(0.15-0.17)	3.0(0.12)
Brake Disk Runout	—	0.02(0.008)
Master Cylinder I.D.	12.700-12.743(0.5000-0.5017)	12.755(0.5022)
Master Cylinder O.D.	12.657-12.684(0.4983-0.4994)	12.645(0.4978)
Caliper Cylinder I.D.	33.960-34.010(1.3370-1.3390)	34.02(1.339)
Caliper Piston O.D.	33.878-33.928(1.3338-1.3357)	33.87(1.333)

#### Torque Values

Brake Caliper Bracket Bolt	3.0kgf-m	Brake Hose Bolt	3.4kgf-m
Brake Caliper Bleed Valve	0.6kgf-m	Front Brake Disk Nut	4.2kgf-m
Brake Caliper Slide Pin	2.3kgf-m	Master Cylinder Reservoir Cap Screw	0.13kgf-m
Brake Caliper Pin Bolt	1.8kgf-m	Brake Lever Pivot Bolt	1.0kgf-m
Brake Pad Pin Bolt	1.8kgf-m	Brake Lever Pivot Lock Nut	1.0kgf-m

### Tools

Special

Snap Ring Pliers

## Troubleshooting

### Brake lever soft or too hard

- Air bubbles in hydraulic system.
- Moisture in brake fluid.
- Brake pad and disk contaminated.
- Caliper piston worn.
- Master cylinder piston worn.
- Brake pad worn.
- Contaminated caliper inner part.
- Incorrectly installed caliper.
- One side of brake pad, disk worn.
- Low fluid level.
- Clogged hydraulic system
- Disc bent
- Sticking, worn caliper piston.
- Disc Worn.
- Contaminated master cylinder inner part.
- Brake lever bent.

### Brake drag

- Clogged hydraulic system
- Sticking caliper piston
- Incorrectly installed caliper
- Clogged brake fluid system
- Caliper piston seal worn
- Master cylinder piston sticking, worn.
- Brake lever bent

### Brake chatter or squeal

- Brake pad, disk contaminated
- Wheel element misaligned
- One side of brake pad, disk worn
- Disc bent
- Incorrectly installed caliper
- Hydraulic system contaminated.

## Brake Fluid / Bleeding

### Brake Fluid Replacement

**⚠ CAUTION**

- A contaminated brake disk or pad reduces stopping power. Discard contaminated pads and clean the disk with a high quality brake degreasing agent.

**⚠ CAUTION**

- Check the fluid level often while filling the reservoir. Avoid spilling fluid on painted, plastic or rubber parts. Place a cloth over these parts whenever the system is serviced.
- Remove the master cylinder cap and diaphragm from the master cylinder. Connect a bleed hose to the caliper bleed valve. Loosen the bleed valve and pump the brake lever until no more fluid flows out of the bleed valve.

### Brake Fluid Filling

- Tighten the bleed valve and fill the master reservoir with DOT 3 or DOT 4 brake fluid to the upper level.
- Install the master cylinder. Operate the brake lever until air bubbles do not appear in the plastic hose.

**⚠ CAUTION**

- Do not mix different types or fluid. They are not compatible.

### Bleeding

- Connect a commercially available brake bleeder to the bleed valve.
- Remove the bleed valve while pumping the brake bleeder.
- Repeat the above procedures until brake fluid appear in the brake bleeder.
- Add brake fluid.

**⚠ CAUTION**

- Check the fluid level often. Add fluid when the fluid level in the master cylinder reservoir is low.
- If air is entering the bleeder from around the bleed valve threads, seal the threads with teflon tape.
- Close the bleed valve and operate the brake lever, check there is air sponge.

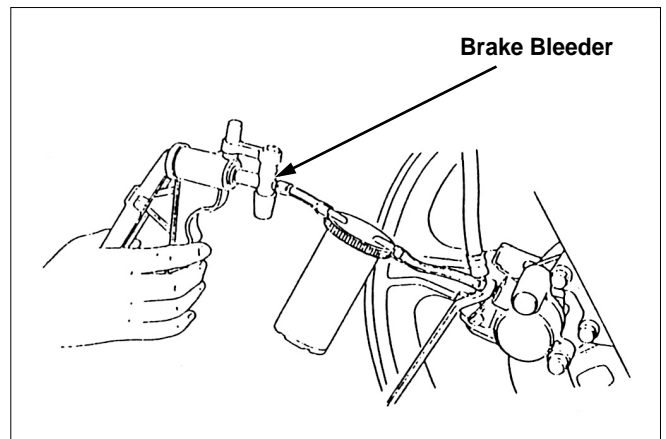
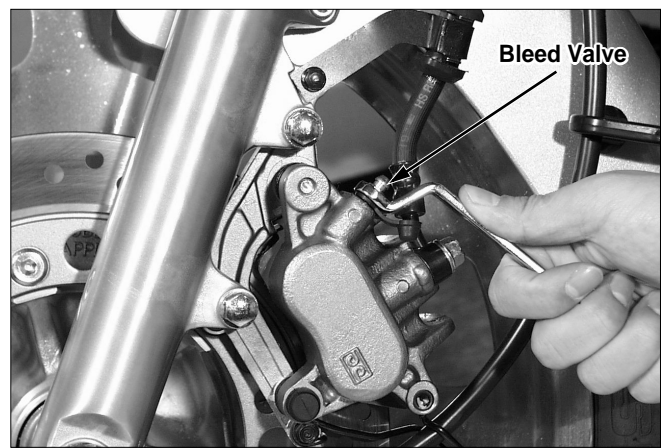
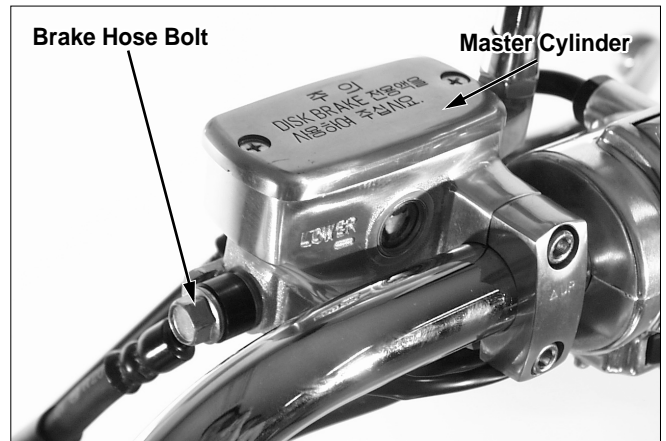

## Hydraulic Brake

- If the brake bleeder is not available, use the following procedure.
- Fill the master cylinder reservoir to the upper level mark. Connect the bleeder hose to the bleed valve and bleed the system as follows.
  1. Squeeze the brake lever, open the bleed valve 1/2 turn and then close the bleed valve.

### \*NOTE

- Do not release the brake lever until the bleed valve has been closed.
2. Release the brake lever slowly and wait several seconds after it reaches the end of its travel.
  3. Repeat step 1 and 2 until air bubbles cease to appear in the fluid coming out of the bleed valve.
- Check the fluid level often. Add fluid when the fluid level in the master cylinder reservoir is low.
  - Do not release the brake lever until the bleed valve has been closed.
  - Tighten the bleed valve.  
Torque: 0.6kgf-m
  - Fill the master cylinder reservoir to the upper level mark with brake fluid. Install the diaphragm, set the master cylinder cap.  
Torque: 0.13kgf-m

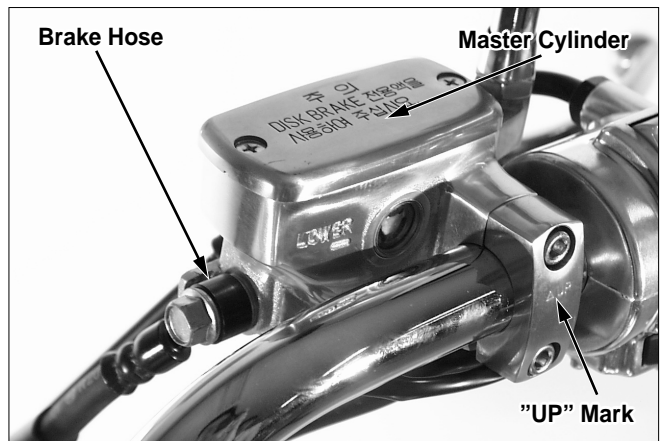
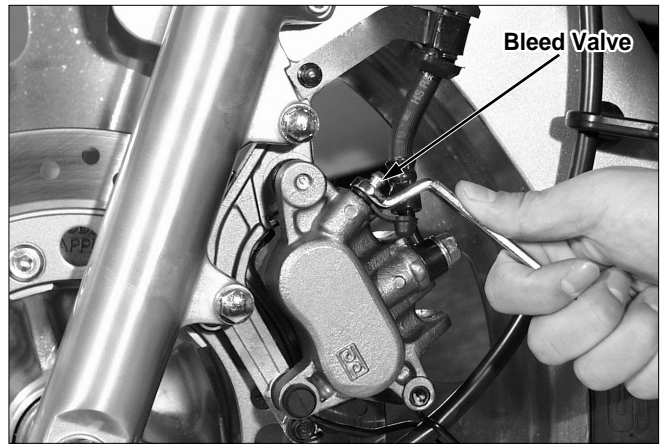

## Brake Pad

### Replacement

#### \*NOTE

- Always replace the brake pads in pairs to assure even disc pressure.
- Replace the brake pads without removing brake hose.
- Loosen the caliper bracket bolt installed to L. front fork.

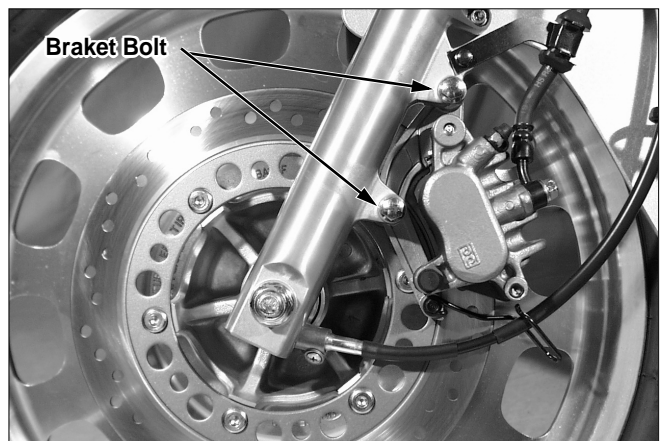

- Remove the brake caliper from the left front fork.

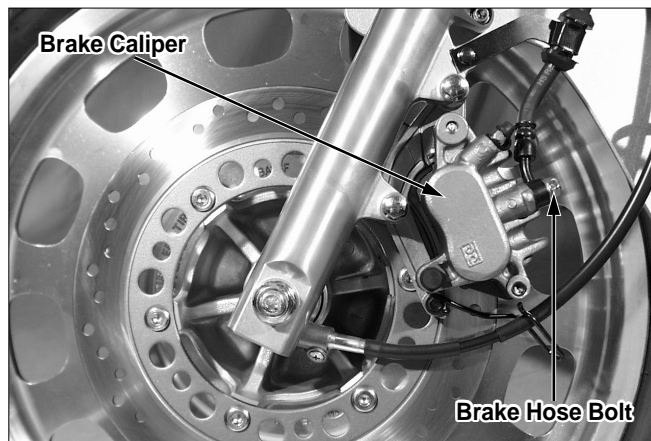

- After removing the hanger pin(1pin) using by L. lench, remove the piston.
- Remove the brake pad.

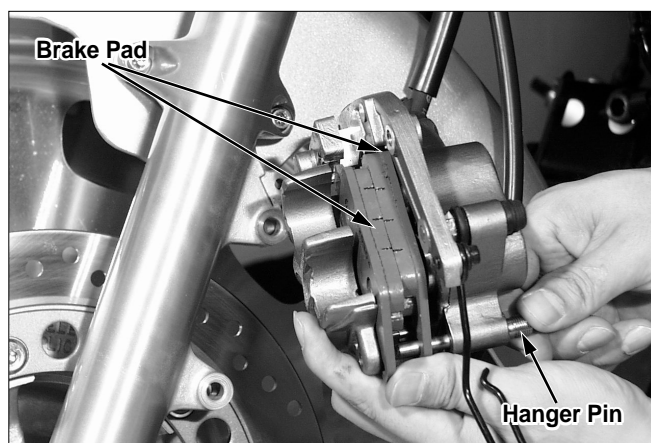

- Make sure that the pad spring is installed in the position shown.

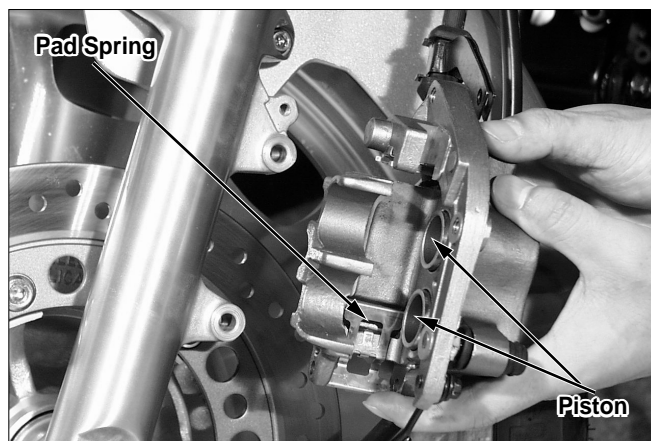

- Install a new brake pad, pad pin retainer, hanger pins.

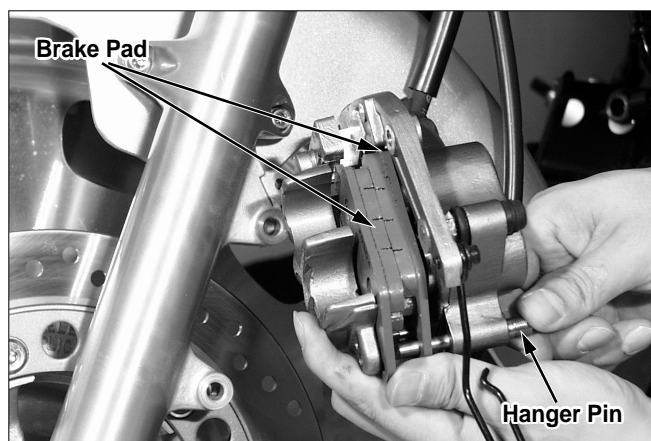

## Hydraulic Brake

- Install the brake caliper into the left front fork.

### \*NOTE

- Be careful not to damage the brake pad.

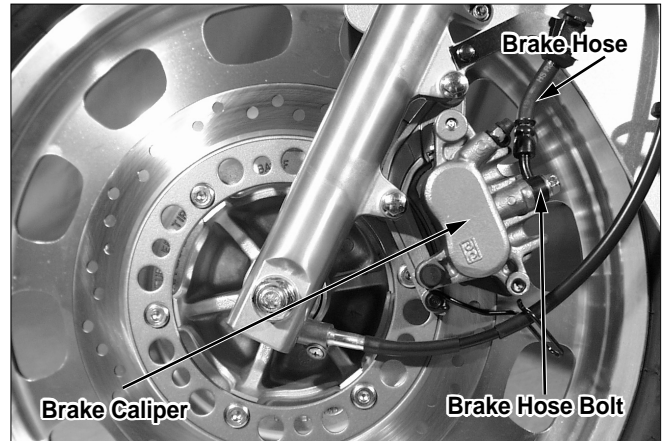

- Tighten the caliper bracket bolt.  
Torque: 3.0kgf-m
- Tighten the hanger pin.  
Torque: 1.8kgf-m

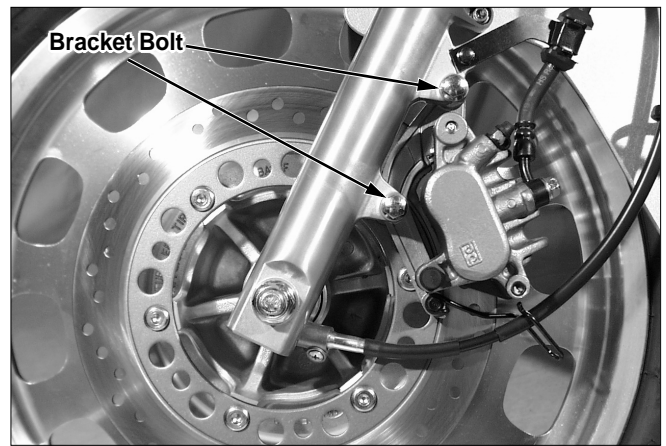

## Brake Disk

### Inspection

- Measure the thickness of the disk.  
Service Limit: 3.0mm(0.12in)



- Measure the Brake disk for warpage.  
Service Limit:0.3mm



## Brake Caliper

### Removal

- Remove the brake hose bolt and brake hose from the brake caliper.
- Remove the caliper from the front fork, then remove the pad pin bolt, brake pad. (⇒14-4)

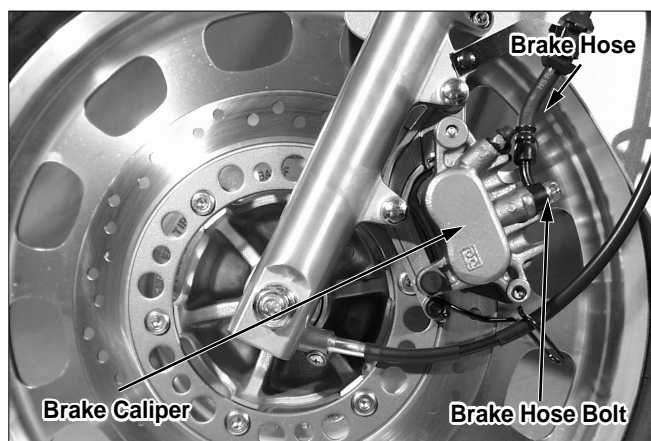

#### \*NOTE

- Avoid spilling brake fluid on painted, plastic, or rubber parts.

#### ⚠WARNING

- A contaminated brake disk or pad reduces stopping power. Discard contaminated pads and clean the disk with a high quality brake degreasing agent.

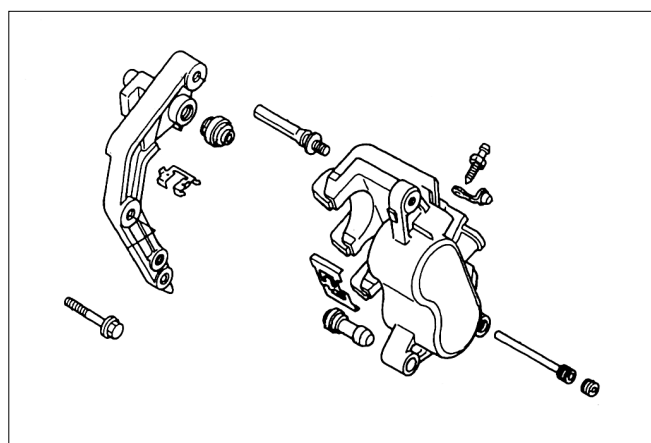

### Disassembly

- Remove the slide pin, caliper bracket, and boot from caliper.
- Must be replaced if the boot is damaged or worn.
- Cover the caliper with cloth in order to avoid the Piston and brake fluid from leakage, and the piston face down.
- Blow the low pressure air slowly in the assembly part of brake hose, and remove the piston from caliper.

#### ⚠CAUTION

- Do not use the high pressure air, or do not close the air conditioner.
- Do not put the hand into the caliper inside.
- Remove the piston seal and dust seal.
- Prevent the caliper inside from damaging.
- Clean the caliper inside and piston with brake fluid.

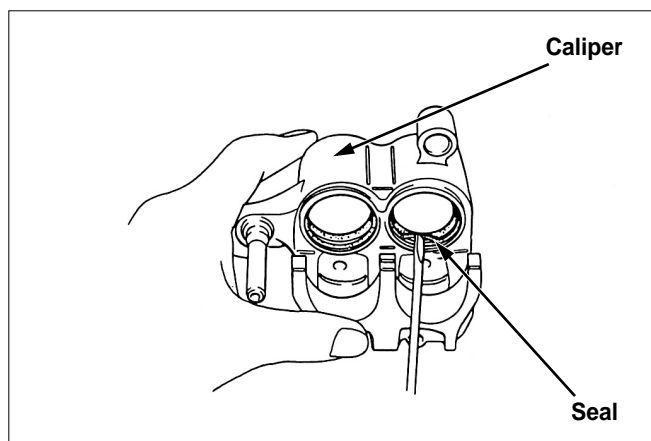
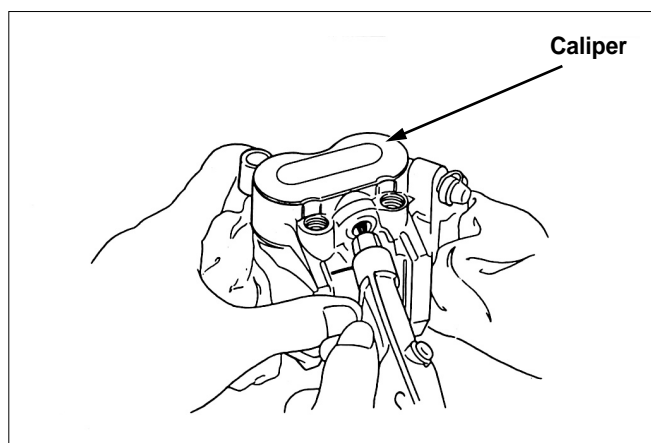



## Hydraulic Brake

### Inspection

- Inspect the caliper friction surface for damaging or crack.
- Measure the caliper inside diameter.  
Service Limit: 34.02mm (1.339in)

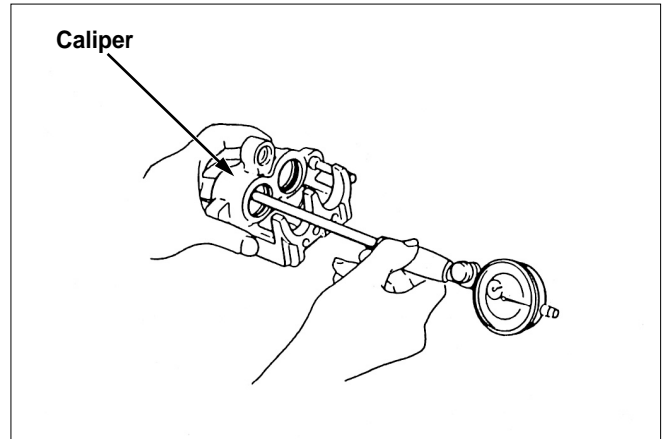

- Inspect the piston outside for damaging or crack.
- Measure the piston outside diameter.  
Service Limit: 33.87mm (1.333in)

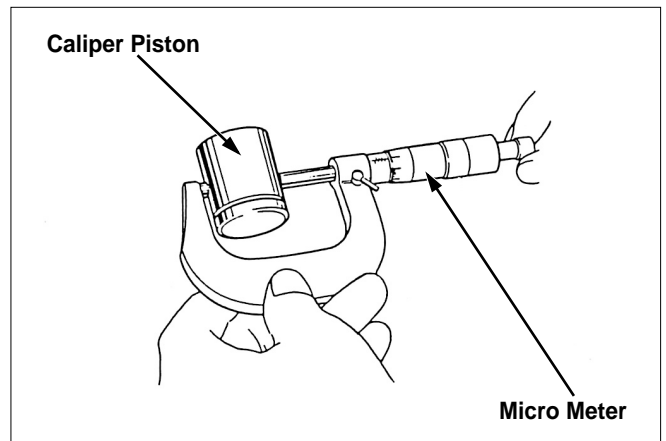

### Assembly

- Clean the piston seal, dust seal with brake fluid, and install of caliper into the 凹 part.
- Install the piston into the caliper by the groove side of piston faces the pad.

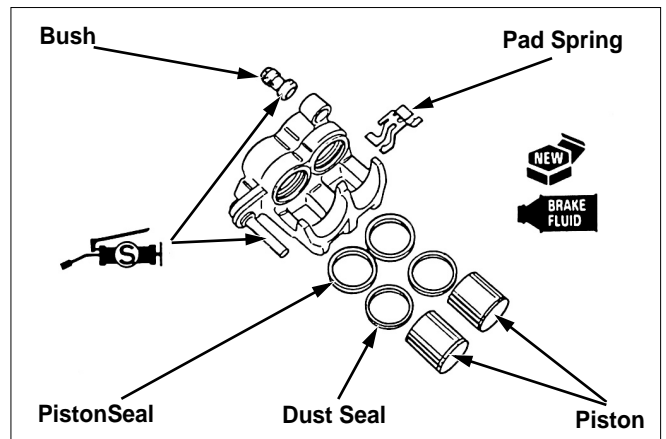

- Coat the boot with the silicon grease.
- Install the boot into the 凹 part of caliper exactly.
- Install the pad spring to caliper. (⇒15-5)
- Install the caliper pin bolt, and install the caliper bracket to caliper.
- Install the brake pad to caliper. (⇒15-5)

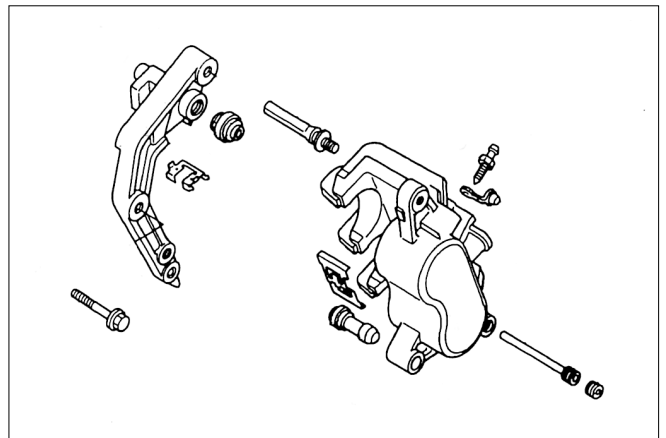

## Installation

- Connect the brake hose to the caliper, and install the 2 sheets of sealing washer and brake hose bolt.  
Torque: 3.4kgf-m
- Install the slide pin cap.
- Fill the brake fluid and bleed the mixed air.  
(⇒15-3)

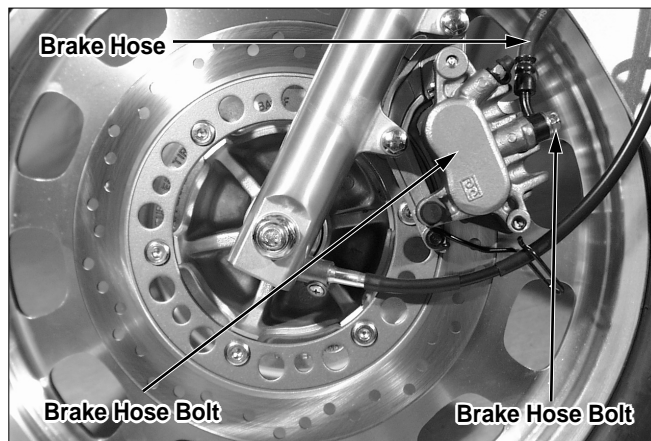

## Master Cylinder

### Removal

- Disconnect the brake light switch wires from the switch. Drain the brake fluid from the hydraulic system. (⇒15-3)
- Remove the brake hose from the master cylinder.

### ⚠CAUTION

- Brake fluid can cause damage to painted, plastic, and rubber surfaces.  
If attached, place a rag over the these parts or clean them with brake fluid or water. Cover the hose joint part to prevent break fluid leakage.
- Clean the removed parts with brake fluid, check for the clogged passage with compressed air.
- Do not allow dust and dirt to stick to the removed parts.
- Remove the master cylinder holder, and take off the master cylinder.

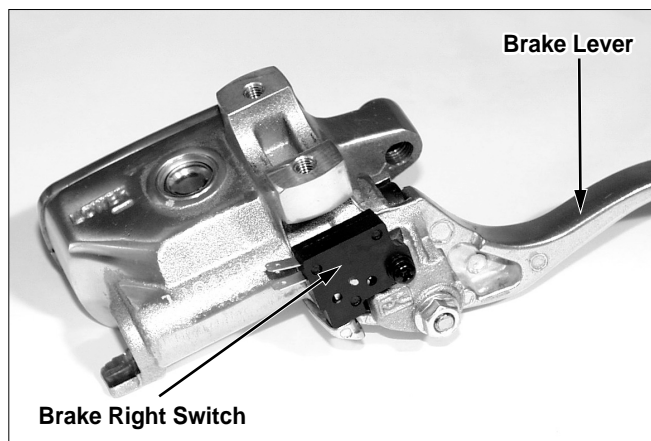
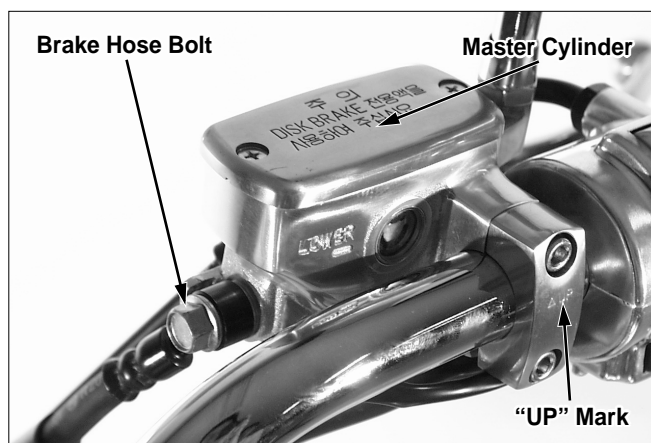

### Disassembly

- Remove the rear mirror, brake lever, and stop switch.
- Remove the piston boot and snap ring form master cylinder.  
Tool: Snap ring plier



## Hydraulic Brake

- Remove the washer, piston, spring from the master cylinder.
- Clean the master cylinder inside, Resorber, master piston with brake fluid.

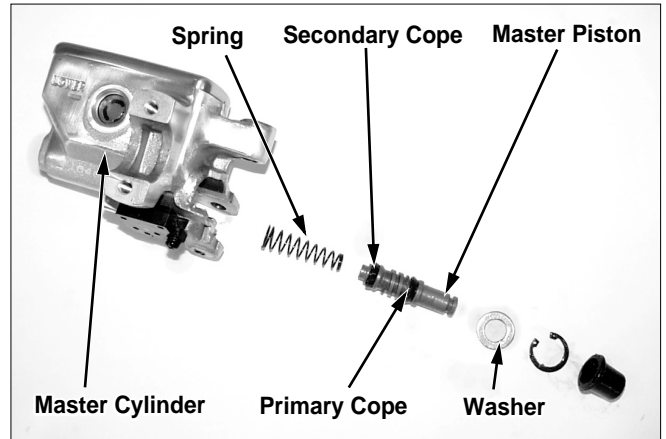

### Inspection

- Inspect the piston circumference for damaging or crack.
- Inspect th primary cope and secondary cope for damaging and wear.
- Measure the master piston outside diameter.  
Service Limit: 12.645mm (0.4978in)
- Inspect the master cylinder friction surface for damaging or crack.
- Measure the master piston outside diameter.  
Service Limit: 12.755mm(0.5022in)

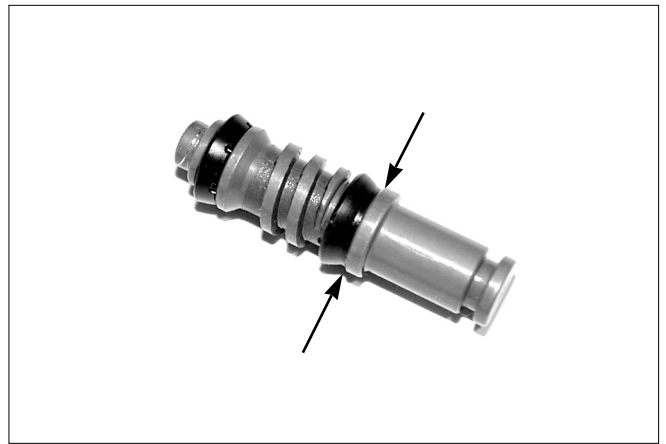

### Assembly

#### ⚠ CAUTION

- Install them after cleaning the dust or dirt of each part.
- The specified parts must be replaced.
- Do not allow foreign material to enter the system when filling the reservoir.
- Do not mix different types of brake fluid. They are not compatible.
- Brake fluid can cause damage to painted, plastic, and rubber surfaces. Place a ran over these parts whenever the system is served.
- Replace the master piston, spring, cup, snap ring as a set.
- Coat the piston cope and master piston with brake fluid.
- Install the spring, piston, washer and snap ring into master cylinder, and fix them with a snap rding.

Tool: Snap ring plier

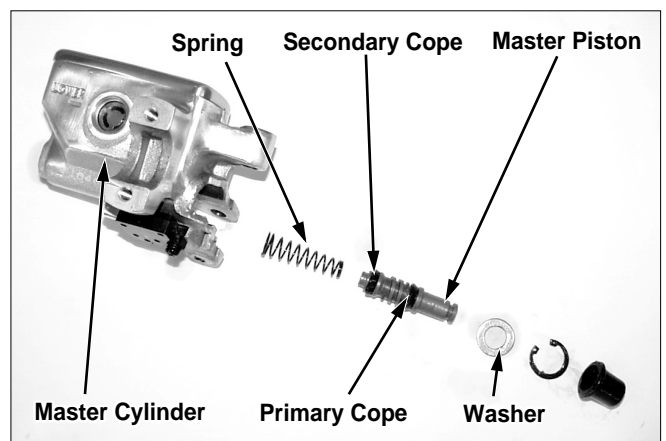
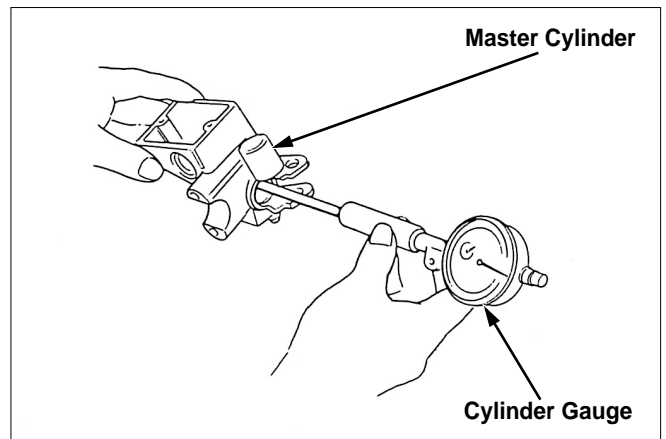

- Install the boot into master cylinder.
- Install the rear mirror, brake lever and stop switch.

Torque: Brake Lever Pivot Bolt  
1.0kgf-m

### Installation

- Place the master cylinder into the handle bar.

#### \* NOTE

- Install the holder with the “UP” mark facing up. Align the end of master cylinder with the punch mark on the handle bar.
- Tighten the upper bolt first, then tighten the lower bolt.
- Install the brake hose to the master cylinder with the hose bolt and two sealing washers.  
Torque: 3.4kgf-m
- Connect the stop switch wires to the switch.
- Fill and bleed the front brake hydraulic system.

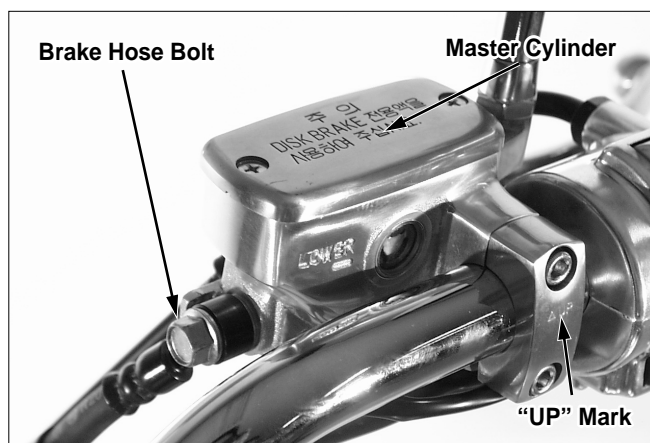
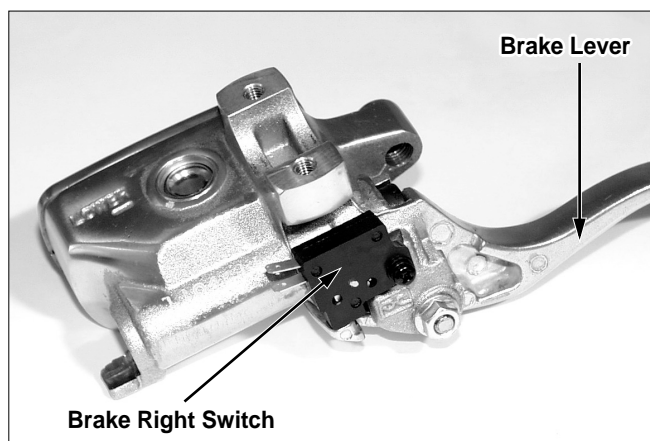

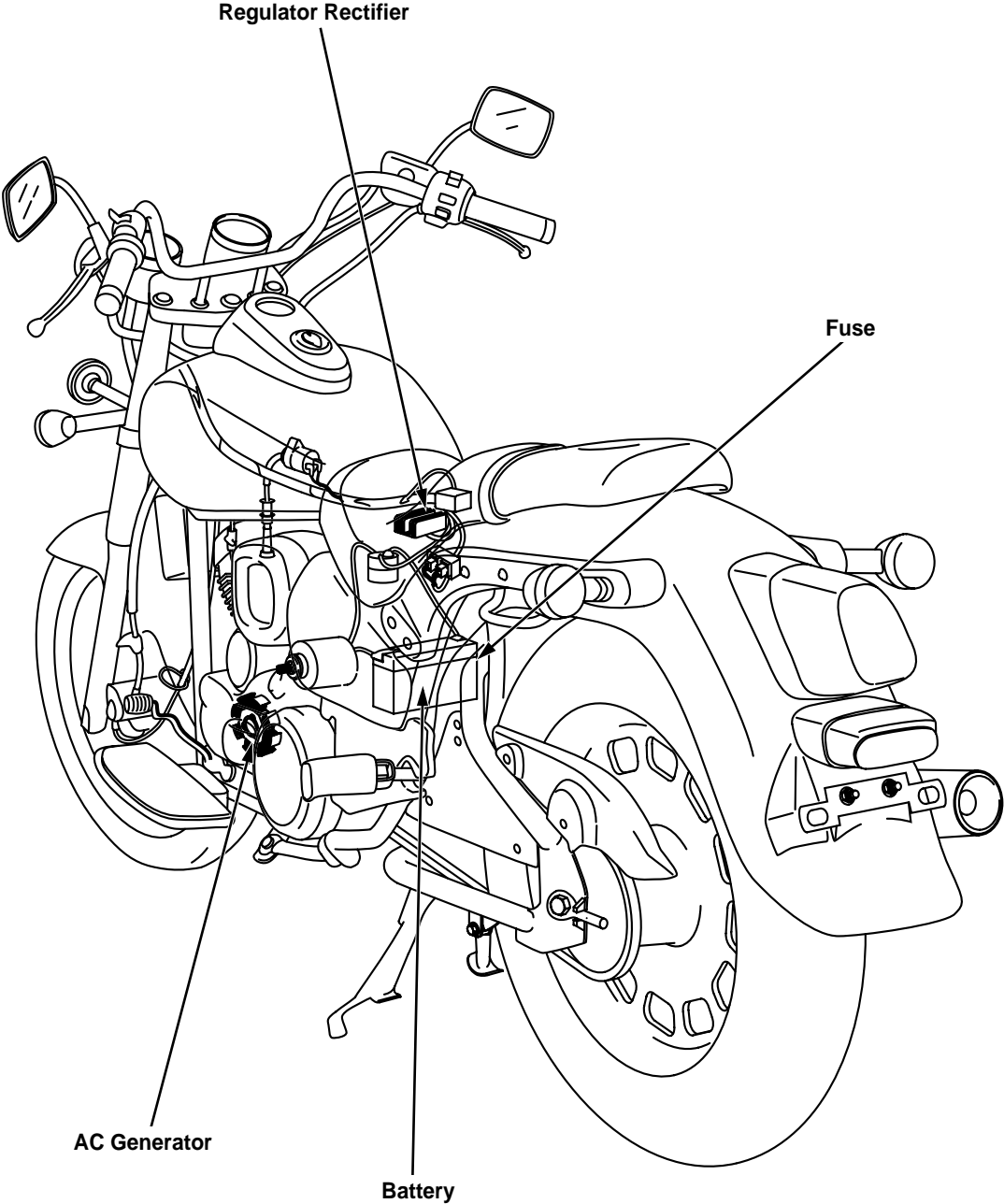

# 16. Charging System / Battery

Service Information .....16-1	Charging System Inspection .....16-5
Troubleshooting .....16-2	Regulator/Rectifier .....16-6
Battery .....16-3	A.C Generator Inspection .....16-7

## Service Information

### General

**⚠ CAUTION**

- The battery contains sulfuric acid (electrolyte). Contact with skin or eyes may cause severe burns.
  - If Electrolyte gets on your skin, flush with water.
  - If electrolyte gets in your eyes, flush with water for at least 15 minutes and call a physician immediately.
- The battery gives off explosive gases; keep spark, flame, and cigarettes away.
- The battery fluid level should be checked regularly. Fill with distilled water when necessary.
- Quick-charge a battery only in an emergency. slow-charging is preferred.
- Charge a battery after removing the battery from the frame.
- All charging system components can be tested on the motorcycle.

### Specification

Item		Standard	
Battery	Capacity	12V-9AH	
	Specific Gravity	Fully Charged	1.280
		Needs Charging	1.260
	Charging Current	Below 0.9A	
	Leak Current	Below 1mA	
Generator	Capacity	125W/5,000(rpm)	
	Charging Coil	0.4-1.2 Ω	
	Charging Startrpm	Below 1,300(rpm)	
Regulator / Rectifier	Type	Transistorized, non-adjustable	
	Regulated Voltage	14.5 ±0.5V/5,000(rpm)	

### Tools

- Measuring Tools
- Digital Circuit Test
- Circuit Tester

### Troubleshooting

#### No power (Main switch turned "ON")

- Dead battery
  - Low fluid level
  - Low specified gravity
  - Charging system failure
- Disconnected battery cable
- Main fuse burned out
- Faulty ignition switch

#### Low power (Main switch turned "ON")

- Weak battery
  - Low fluid level
  - Low specific gravity
  - Charging system failure
- Charging system failure
- Loose battery connection

#### Low power (Engine running)

- Low fluid level
- One or more dead cells
- Battery undercharged
- Faulty battery
- Charging system failure

#### Intermittent power

- Loose battery connection
- Loose charging system connection
- Loose starting system connection
- Loose connection or short circuit in ignition system
- Loose connection or short circuit in lighting system

#### Charging system failure

- Loose, broken or shorted wire or connector
- Faulty voltage regulator rectifier
- Faulty A.C. generator

# Battery

## Removal

- Remove the right side cover.
- Disassemble the battery holder.
- Remove the battery cable from the battery terminal.

**⚠ CAUTION**

- Remove the battery negative cable from the battery first, then the positive cable.
- Disconnect the battery bleed tube from the battery and remove the battery.

**⚠ CAUTION**

- When removing the tube, avoid the battery fluid from getting in your eyes or on your skin because the bleed tube is often covered with the battery fluid.

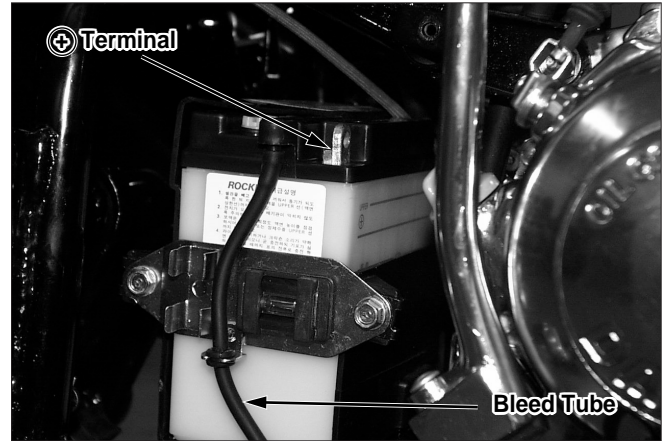

## Specific Gravity

- Measure the battery specific gravity.
- Specific gravity(at 20 °C).  
1.280 :Fully Charged  
Below 1.260:Needs charging

**⚠ CAUTION**

- The battery needs charging when the specific gravity is below 1.230
- The specific gravity changes according to the battery temperature as shown.
- Replace the battery with a new battery when it has white cells.
- Replace the battery with a new one when it has a deposit in the lower part of the battery.

**⚠ CAUTION**

- The battery electrolyte contains sulfuric acid.
- Avoid contact with skin or clothing. If electrolyte gets in your eyes, flush them thoroughly with water and get prompt medical attention.

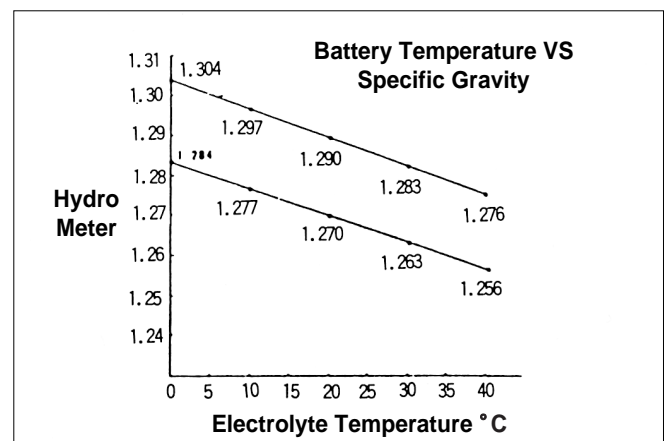
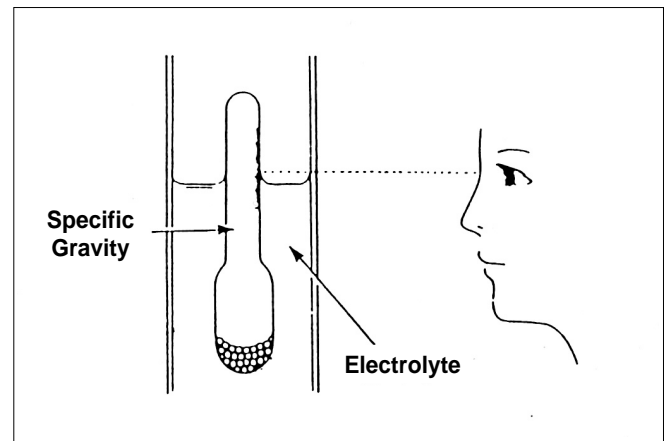



## Charging System/Battery

### Charging

- Remove the battery caps.
- Fill the cells with distilled water to the upper level, if necessary.
- Connect the charger positive  $\oplus$  cable to the battery positive  $\oplus$  terminal.
- Connect the charger negative  $\ominus$  cable to the battery negative  $\ominus$  terminal.
- Charge the battery until specific gravity is 1.270~1.290{20°C(68°F)}.

#### ⚠CAUTION

- Before charging a battery, remove the cap from the each cell.
- Keep flames and sparks away from a charging battery.
- Turn power ON/OFF at the charger, not at the battery terminals to prevent spark.

#### ⚠CAUTION

- Discontinue charging if the electrolyte temperature exceeds 45°C (113°F)
- Quick charging should only be done in an emergency: slow charging is preferred.

### Assembly

- Assembly is essentially the reverse order of disassembly.

#### ⚠WARNING

- The bleed tube may contains the battery fluid and the battery fluid causes damages to the battery.
- Connect the bleed tube into the battery correctly.
- Be careful not to bend the battery tube. Bent battery tube causes battery explosion.
- Connect the charger positive  $\oplus$  cable to the battery positive terminal first, then connect the charger negative  $\ominus$  cable to the battery negative terminal.

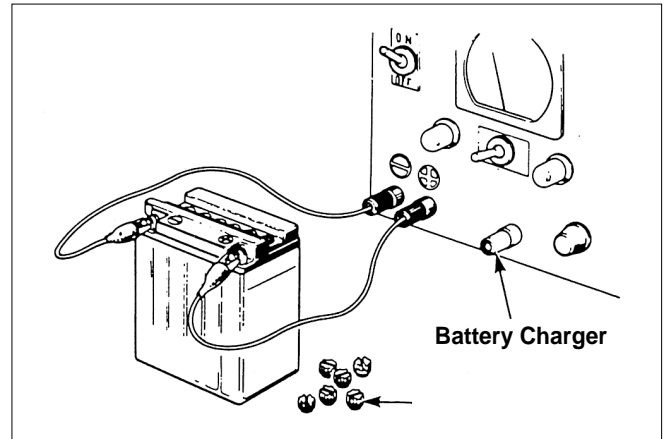

## Charging System Inspection

### Leakage Inspection

- Turn the ignition switch OFF. Remove the negative cable from the battery.
- Connect the voltmeters between the negative cable and battery negative  $\ominus$  terminal.
- Measure the leakage voltage with the main switch OFF.

#### ⚠ CAUTION

- When measuring much voltage than the upper level of range, the fuse may be burned out. Ampere meter measure by changing from big range to small range gradually.
- Don't turn the main switch ON during measuring the voltage. When measuring by the small voltage range as like 1 mA range, the fuse of tester may be burned out because much voltage flow.
- If the voltage leakage is over 1mA, check the wire harness to be sure the connection is good and the wires are not damaged. Recheck the

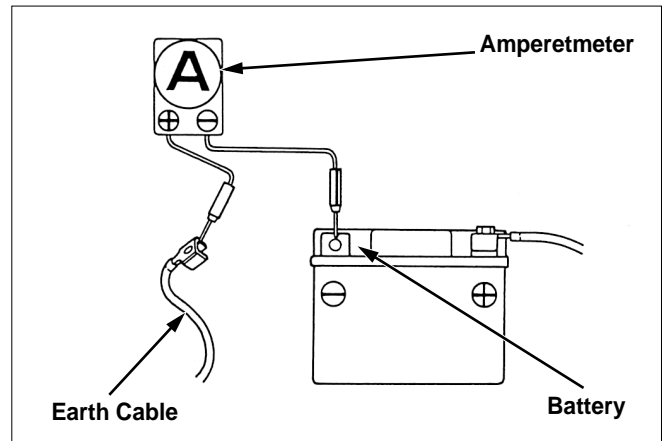

### Charging Output Inspection

#### ⚠ CAUTION

- As voltage is changeable according to the charging state, inspect the charging output in state of fully charged battery.
- Use the battery which the specific gravity is over 1,270.  $<20^{\circ}\text{C}(68^{\circ}\text{F})>$
- If the engine starts with a starter motor, a lot of voltage flow for a while because the energy of battery is spended when starting the engine.
- Start the engine and warm it up to operating temperature. Install a fully charged battery.
- Connect the voltmeter (digital tester) between the positive and negative terminals of the battery.  
Tool: PVA multi tester
- Start the engine. Gradually increase the engine speed and check that the voltage is regulated.  
Regulated Voltage:  $14.0 \pm 0.5\text{V}/5,000(\text{rpm})$

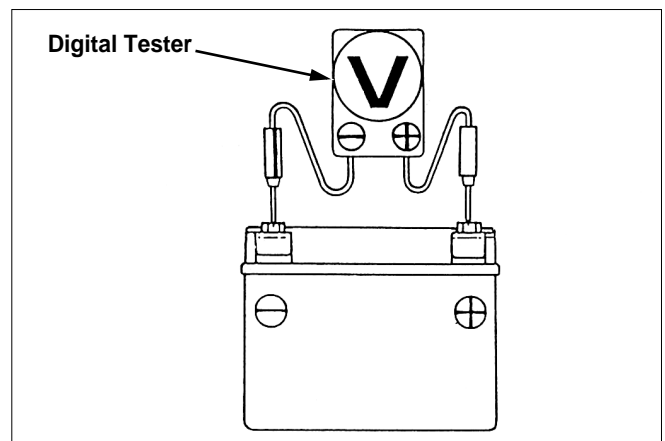

### Regulator/Rectifier

#### Inspection of the harness circuit

- Remove the left front side cover.
- Disconnect the voltage regulator / rectifier coupler.
- Check for continuity between each terminal and ground.

#### Inspection

Item	Probe
Battery(Red)	Continuity between red $\oplus$ and ground $\ominus$
Ground lead (Green)	Continuity between green and ground
Charging coil lead(Yellow)	Yellow-yellow standard resistance, no continuity between yellow and ground.
Voltage detection lead(Black)	When the main switch is "ON" between black $\oplus$ and green $\ominus$ , there is continuity.



#### Regulator/Rectifier Inspection

- If there is no problem in the starter inspection, check the regulator/rectifier coupler. Measure the resistance between the connector terminals.

#### ⚠ CAUTION

- If the fingers reach to the metal part of tester handle during the inspection, the resistance of the human body is indicated. Therefore, be careful of that
- Must inspect using the defined tester as the below. If being inspected by different tester, can not be inspected exactly because strange resistance value is indicated.
- Measure the resistance using the DAELIM PVA multi-tester.
  - PVA multi-tester

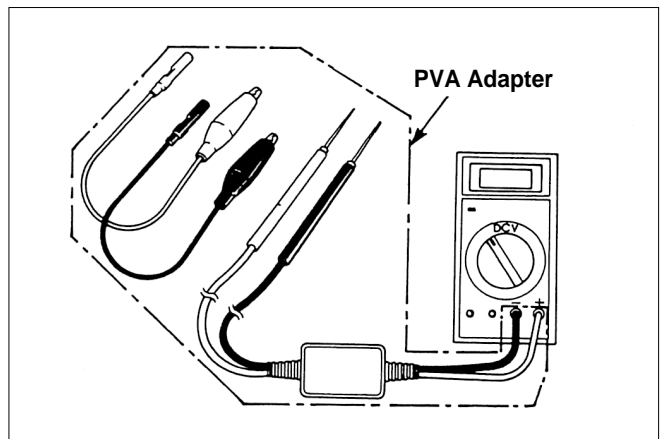

- Replace the regulator / rectifier if the resistance is out of specification.

Unit: k  $\Omega$

(-)(+)	Red	Black	Yellow	Yellow	Green
Red		$\infty$	$\infty$	$\infty$	$\infty$
Black	1-30		0.05-20	0.5-20	0.2-1
Yellow	0.5-10	$\infty$		$\infty$	$\infty$
Yellow	0.5-10	$\infty$	$\infty$		$\infty$
Green	1-30	0.2-1	0.5-10	0.5-10	

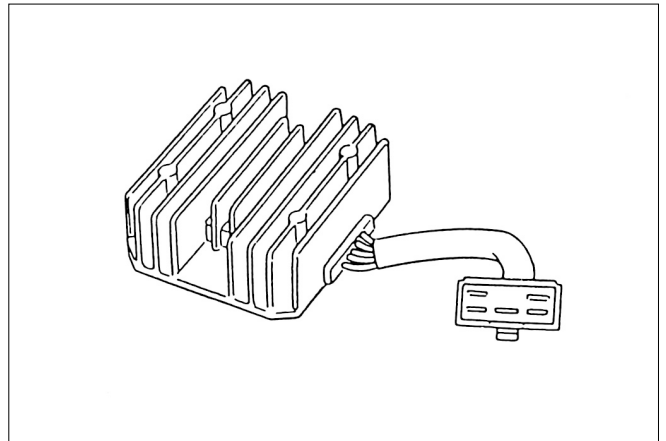

### Replacement

- Remove the Seat.
- Disconnect the wire coupler of the regulator/rectifier connectors. Remove the voltage regulator/rectifier by removing the two flange bolts
- Installation is the reverse order of removal.

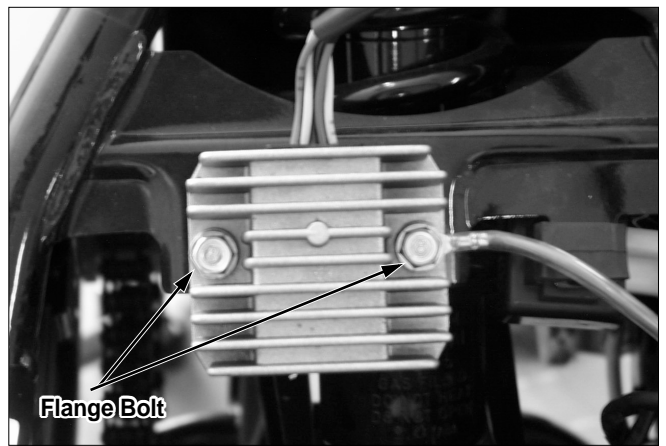

### A.C Generator Inspection

- Disconnect the 3P coupler of the generator code.
- Measure the resistance between the yellow leads.  
Standard Resistance: 0.4~1.2  $\Omega$  (20 °C/68 °F)
- Measure the resistance between the yellow leads and engine ground.

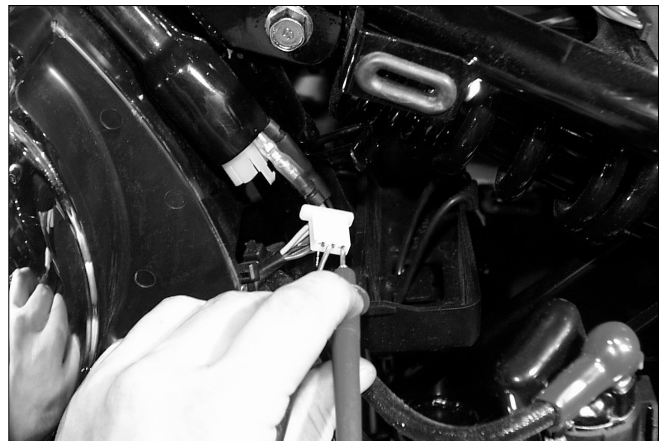

# Ignition System

---

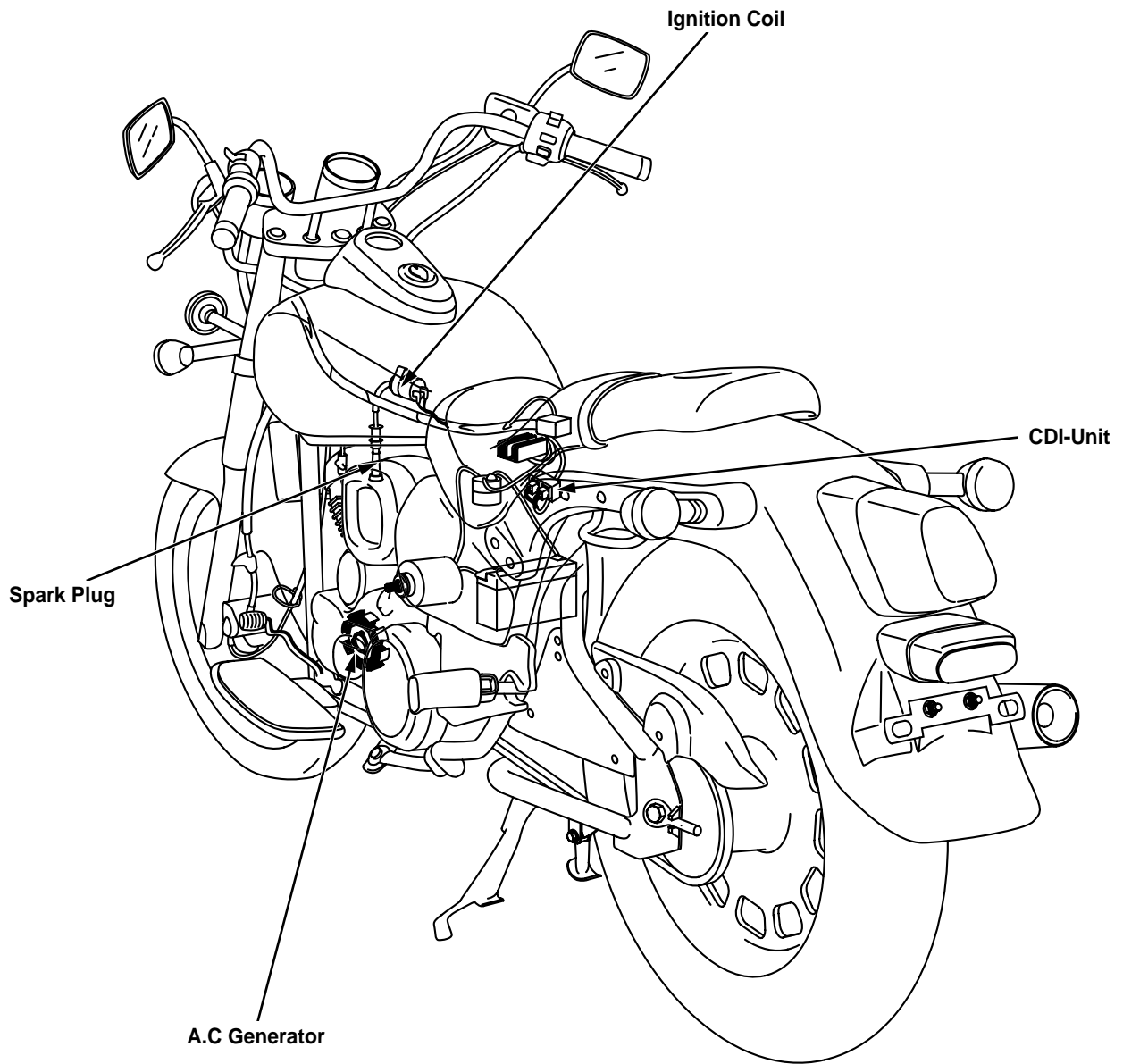

## 17. Ignition System

<b>Service Information</b> .....	<b>17-1</b>	<b>Pulse Generator</b> .....	<b>17-5</b>
<b>Troubleshooting</b> .....	<b>17-2</b>	<b>A.C. Generator Inspection</b> .....	<b>17-5</b>
<b>C.D.I Unit</b> .....	<b>17-3</b>	<b>Ignition Timing Inspection</b> .....	<b>17-6</b>
<b>Ignition Coil Inspection</b> .....	<b>17-4</b>		

### Service Information

#### General

- Inspect the ignition system in proper sequence based on the troubleshooting.
- Dropping or giving a shock to the C.D.I unit causes a trouble.
- There should be battery voltage with the ignition and engine stop switched ON. Turn the main switch OFF while serving.
- C.D.I ignition system is used and it can not be adjusted.
- Couplers are connected to other couplers which have same colour.
- Coil standard resistance may not be obtained due to the different measuring circumstances.

#### Specifications

Item		Standard	
Ignition coil resistance 20 °C(68 °F)	Primary Coil	0.21 ±0.02 Ω	
	Secondary Coil	With the spark plug cap	5 ±1.25 kΩ
		Without the spark plug cap	3.1 ±0.1 kΩ
Pulse generator coil resistance 20 °C(68 °F)		95-135 Ω	
A.C generator coil resistance 20 °C(68 °F)		100-140 Ω	
Ignition timing	F mark	8° BTDC / 1,400(rpm)	
	Full advance	28° BTDC / 3,900(rpm)	

#### Tools

- Measuring tools
- Digitalcircuit tester
- Circuit tester
- Inspection adapter
- Spark adapter

### Troubleshooting

#### No spark at plug

- Poorly connected, broken or shorted wires
  - Between A.C. generator and C.D.I unit
  - Between C.D.I unit and ignition coil
  - Between ignition coil and plug
- Faulty main switch
- Faulty ignition coil
- Faulty C.D.I unit
- Faulty A.C. generator
- Faulty pulse generator

#### Engine starts but runs poorly

- Ignition primary circuit
  - Faulty ignition coil
  - Loose or bare wire
- Secondary circuit
  - Faulty plug
  - Faulty high tension code
- Timing advance incorrect
  - Faulty A.C. generator
  - Faulty C.D.I unit
  - Faulty pulse generator

## C.D.I Unit

### C.D.I Ignition Circuit Inspection

**\* NOTE**

- Inspect the ignition system in proper sequence based on the troubleshooting table.
- Remove the side cover.
- Disconnect the CDI unit coupler, and measure the voltage between the terminals of the CDI unit coupler at the Harness side coupler.



Inspection Item	Terminal	Standard
Pulse Generator	Blue/Yellow & Green/White	95~135 Ω 20 °C(68 °F)
Ignition Coil(Primary Coil)	Black/Yellow & Ground ( - )	0.21 ±0.02 Ω 20 °C(68 °F)
AC Generator	Black/Red & Ground ( - )	100~140 Ω 20 °C(68 °F)
Main Switch	Black/White (+) & Ground ( - )	No continuity, When the main switch is ON
Wire Stator Ground	Green & Ground ( - )	Continuity

### Inspection by CDI Tester

- Measure the resistance using the DAELIM PVA multi-tester  
- PVA multi-tester

**⚠ CAUTION**

- Well read the instruction manual of tester and handle it.
- Replace the CDI unit if necessary.

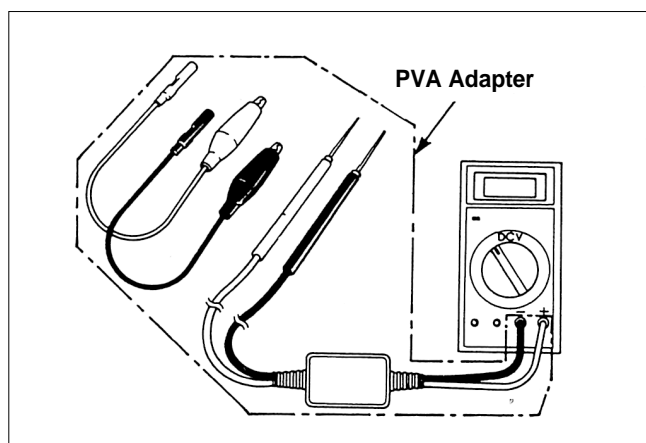



### Ignition Coil Inspection

- Remove the seat
- Remove the Fuel Tank
- Disconnect the primary circuit.
- Measure the ignition coil primary coil resistance between the ignition coil terminal and ground.  
Standard: (Resistance)  $0.2 \pm 0.02 \Omega$   
(Voltage) Over 100V
- Disconnect the spark plug caps from the spark plugs.
- Measure the secondary coil resistance between the ignition coil spark plug caps and ground.  
Standard:  $5 \pm 1.25 k\Omega$

#### \* NOTE

- Don't measure the secondary coil voltage of ignition coil.
- If the measurement is out of specification, check the secondary coil resistance without the plug caps from the high tension code.

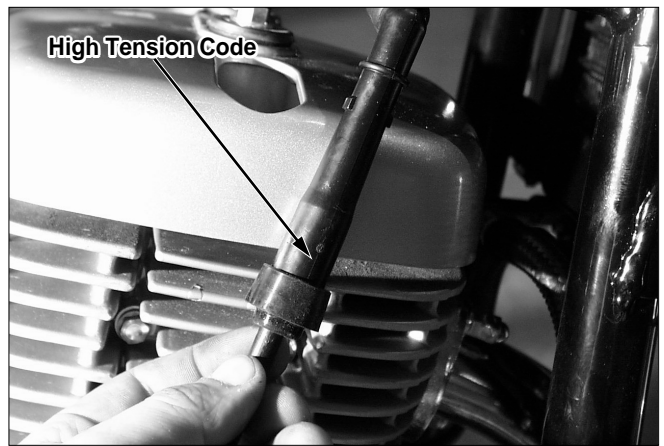
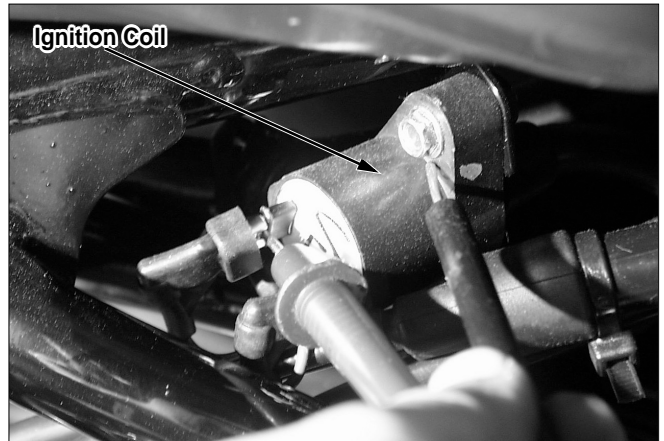

### Replacement

- Disconnect the tension code from the plug and clamp. Remove the primary circuit from the ignition coil. Loosen the two bolts and remove the ignition coil.
- Installation is the reverse order of removal.

### Performance Test

- Measure it using the DAELIM PVA multi-tester.  
- PVA multi-tester

**⚠ CAUTION**

- Well read the instruction manual of tester and handle it.

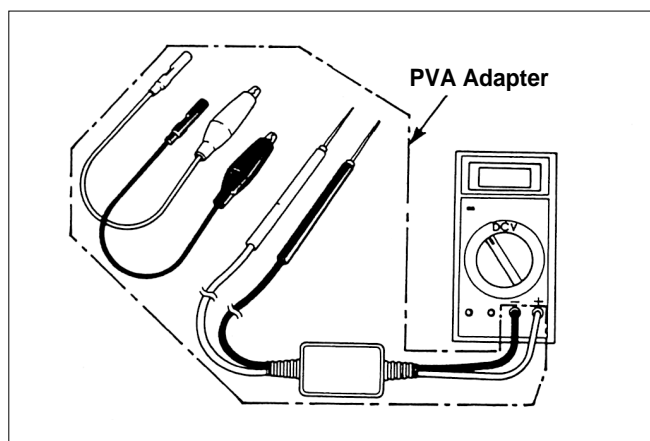

### Pulse Generator

- Disconnect the AC generator 3P coupler blue/yellow wire connector.
- Measure the resistance between green/white and blue/yellow.  
Standard: (Resistance)95-135Ω (20 °C/68 °F)  
(Voltage) Over 0.7V

**\* NOTE**

- If the standard resistance is not obtained, check all the related parts for the troubleshooting.
- Replacement of the pulse generator: refer to section 7.

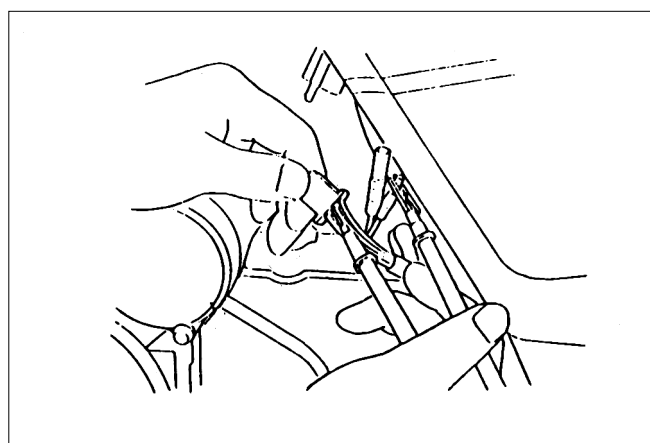

### A.C Generator Inspection

- Disconnect the AC generator coil wire (black/red).
- Measure the resistance between black/red and ground.  
Standard: 100-140Ω (20 °C/68 °F)

**\* NOTE**

- If standard resistance is not obtained, check all the related parts for the troubleshooting.

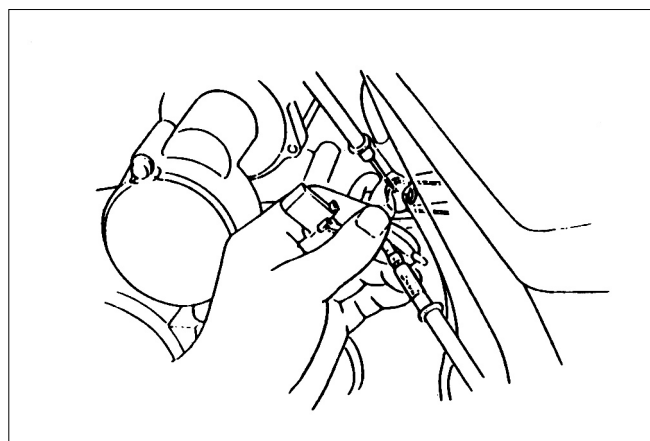

### Ignition Timing Inspection

**\*NOTE**

- A CDI ignition system is used and it can not be adjusted. Inspect the ignition system if ignition timing is incorrect.

- Start the engine and warm it up.
- Remove the timing hole cap.
- Install the timing light into the high tension code.

**\*NOTE**

- Handle the timing light properly according to the service information.
- Remove the timing hole cap from the left crank case cover and start the engine.
- Align the “F” mark on the rotor with the index mark on the case cover when specified idle rotates.  
Idle Speed:  $1,400 \pm 100$ (rpm)
- Gradually increase the engine speed. If the index mark is placed on the preceded “F” mark inside at over 3,900(rpm), the function of the advance system is correct.

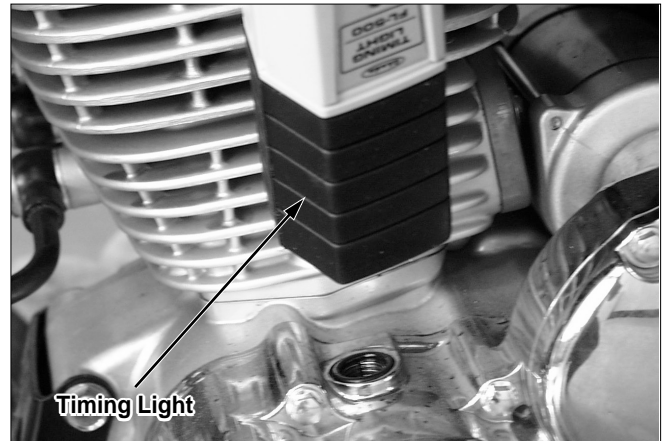



**Electric Starter**

---

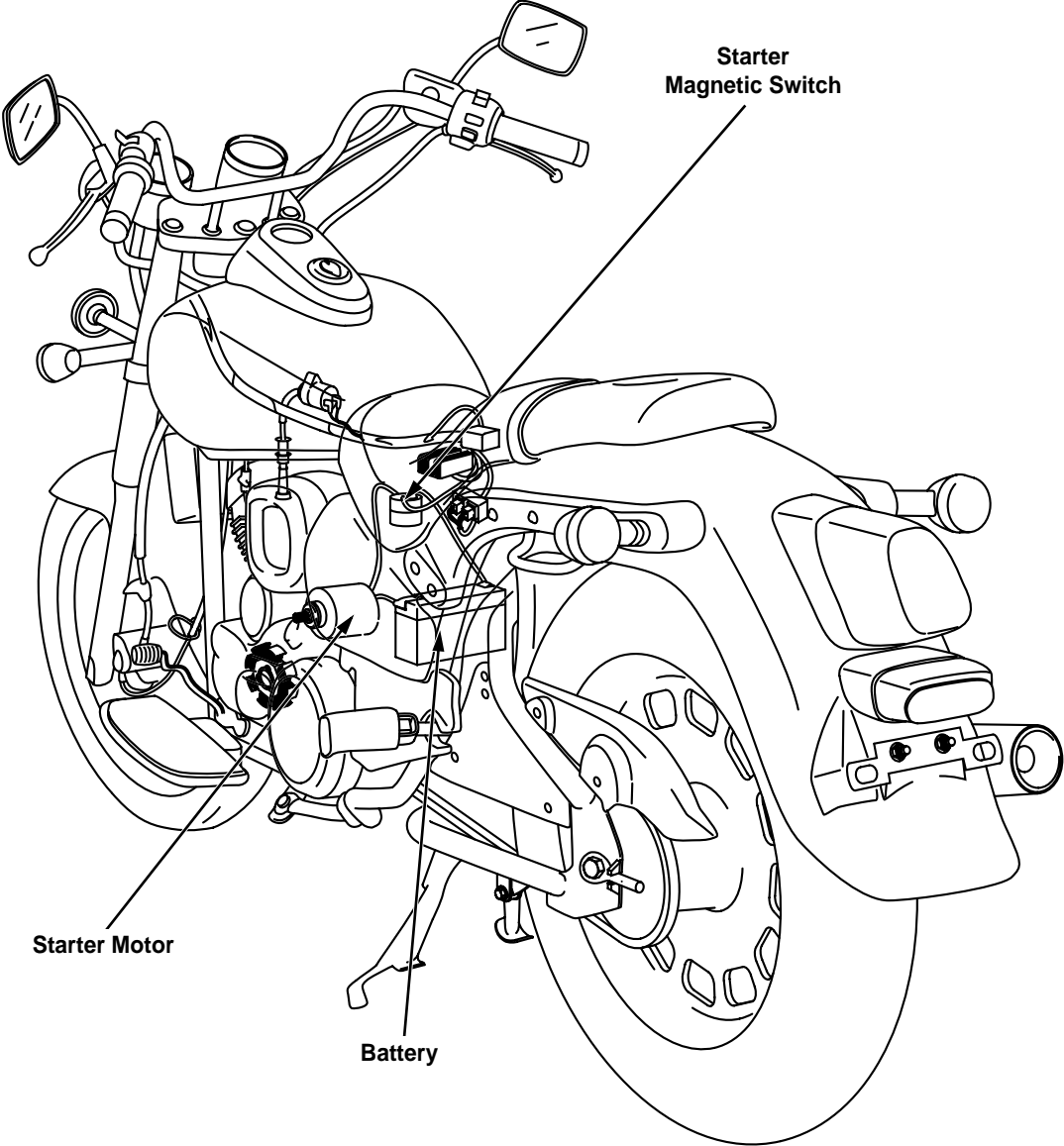

# 18. Electric Starter

<b>Service Information</b> .....	<b>18-1</b>	<b>Starter Motor</b> .....	<b>18-2</b>
<b>Troubleshooting</b> .....	<b>18-1</b>	<b>Starter Magnetic Switch</b> .....	<b>18-5</b>

## Service Information

### General

- The Starter motor can be serviced with the engine in the frame.

### Specification

Unit: mm(in)

Item	Standard	Service Limit
Starter Motor Brush Length	12.5-13.0(0.49-0.51)	8.5(0.33)
Starter Motor Brush Spring Tension	680-920g	350g

## Troubleshooting

### Starter motor will not turn

- Battery discharged
- Faulty main switch
- Faulty starter switch
- Faulty starter magnetic switch
- Loose or disconnected wire cable

### Starter motor turns engine slowly

- Battery discharged
- Excessive resistance in circuit
- Binding in starter motor

### Starter motor turns, but crank shaft does not turn

- Faulty starter clutch
- Faulty starter motor gear
- Faulty starter motor or idle gear

### Starter motor runs and crank shaft turns, but engine does not start

- Faulty ignition system
- Engine problems

## Starter Motor

### Removal

**⚠ CAUTION**

- Turn the main switch OFF before servicing the starter motor.
- The main switch ON brings about an injury.

- Remove the starter motor cable from the motor.
- Remove the starter motor mounting bolt, and starter motor.

### Disassembly

- Remove the following parts
  - Motor case
  - Front cover, rear cover
  - Armature

**⚠ CAUTION**

- Check the trust washer for position and number of sheet.

### Inspection

- Measure the brush length.  
Service Limit: 8.5mm (0.33in)

- Measure the spring tension.  
Service Limit: 350g (771lb)

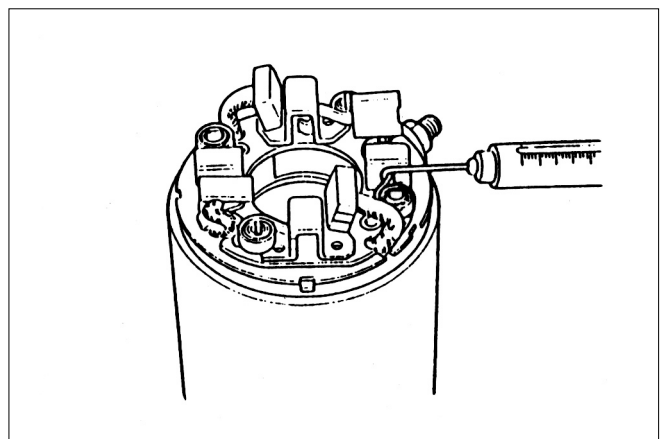
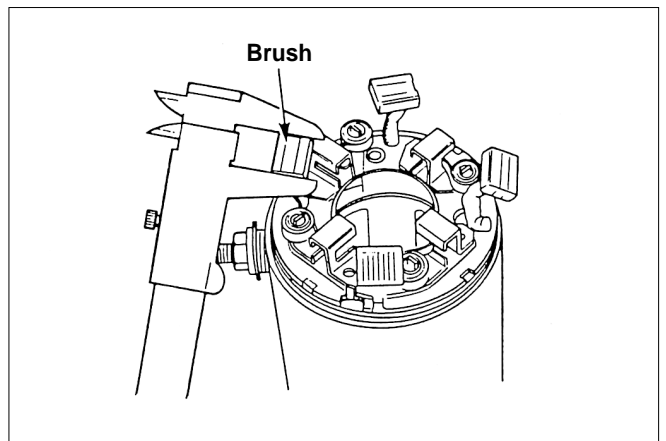
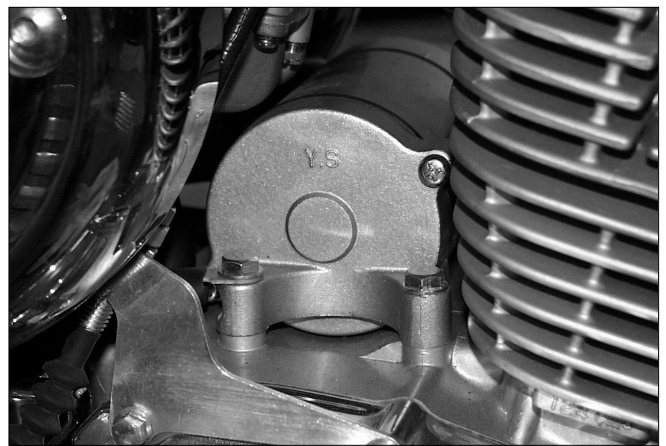
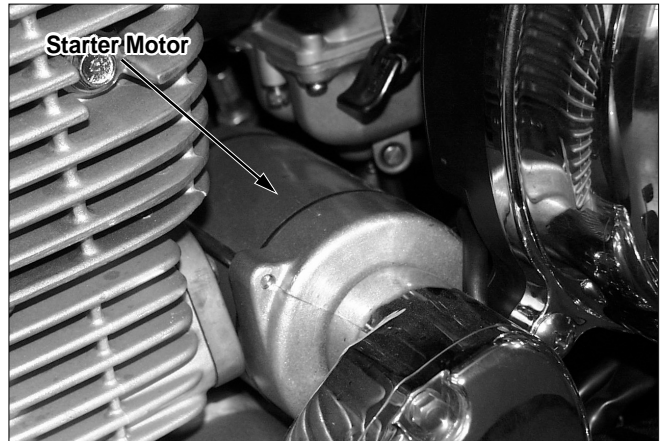

- Inspect the continuity between cable terminal and case. Inspect the continuity between the terminal and brush. If it doesn't have continuity between cable terminal and case, it is OK.
- If it doesn't have continuity between the cable terminal and Brush (Case side), it is OK.
- Replace or repair them if necessary.

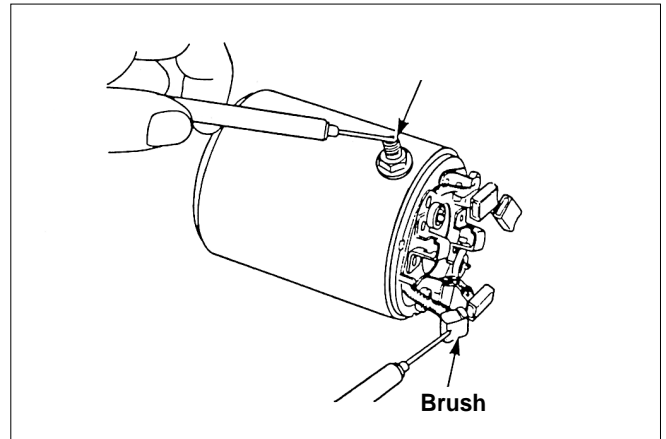

- Inspect the commutator part of the armature for discoloration.
- If over 2 segments are discolored, must be replaced because they are disconnected.

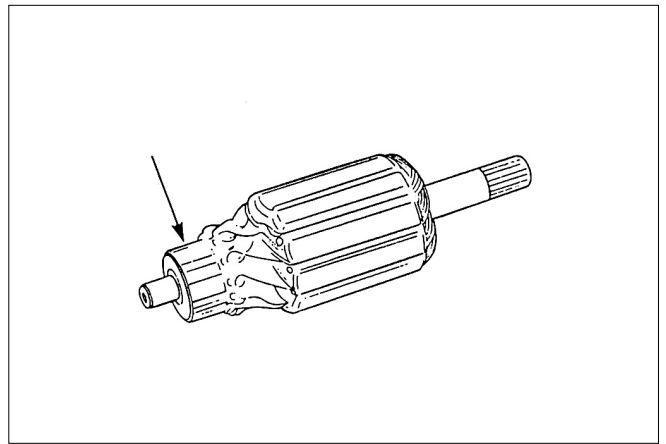

- Inspect between each part of commutator for continuity.
- There should be continuity.

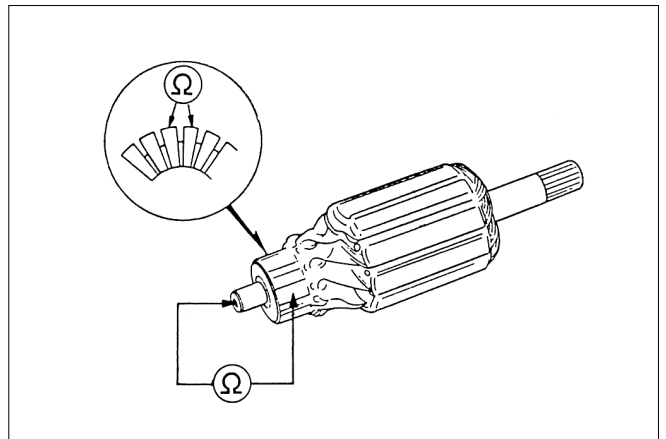

- Inspect between each part of commutator and armature shaft for continuity
- There should not be continuity.



## Assembly

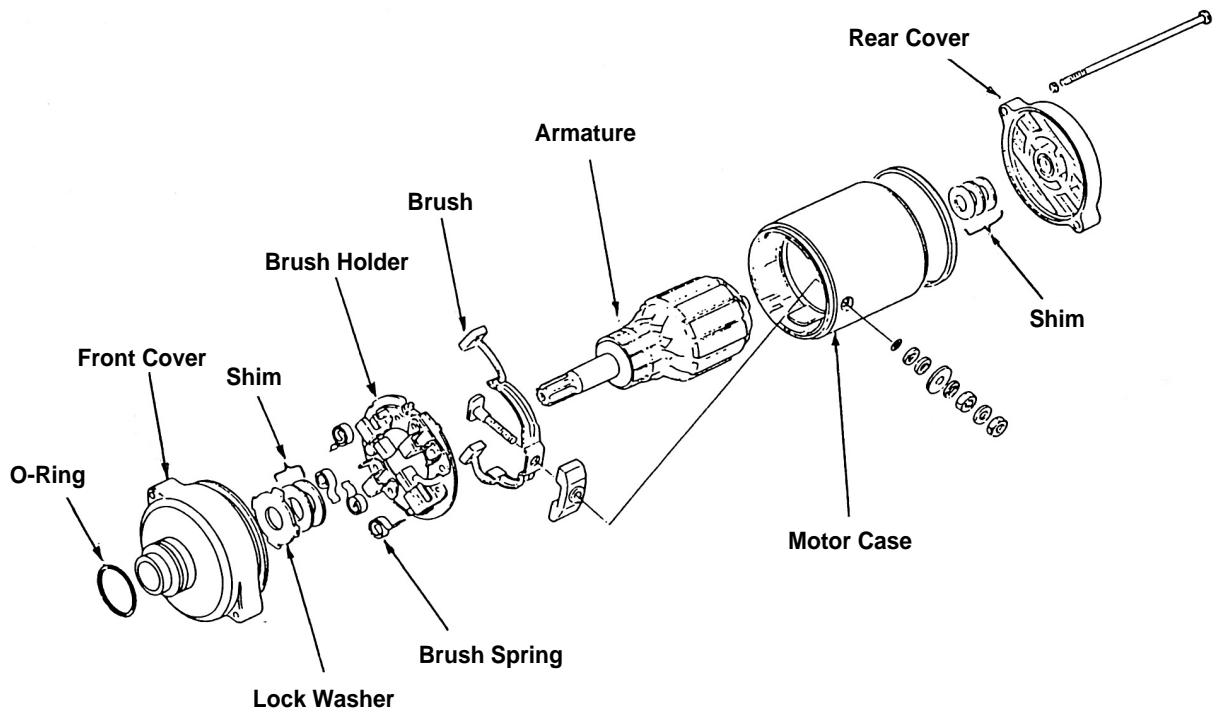

- Insert the armature into the brush holder center with driving each brush into the brush holder inside.
- Install the holder into the case aligning the projecting part of brush holder with the  $\square$  part of case.



- When removing the shim, install it by recorded order.
- Install the lock washer.
- Align the groove of front cover with the pin of brush holder and install them.

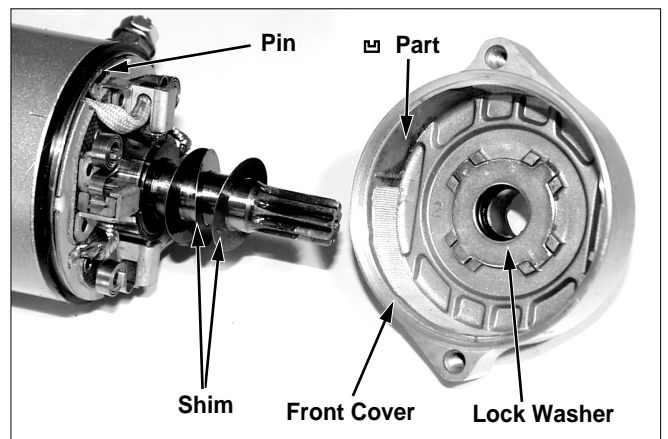

- Align the rear cover with the case mark and install the 2 setting bolts.
- Tighten the setting bolts exactly.

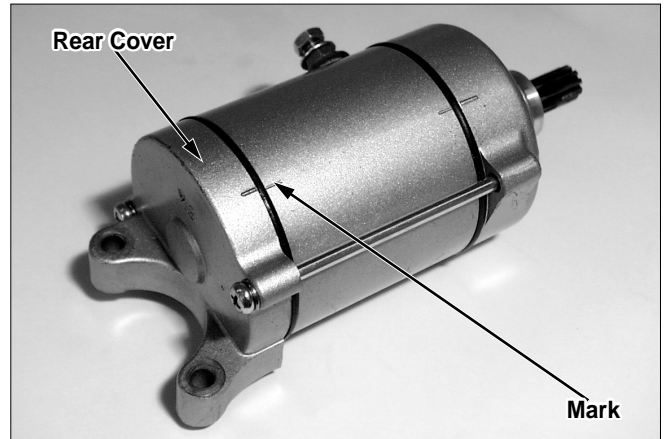

### Installation

- Install a new o-ring into the front cover. Coat the o-ring with oil and install the starter motor into the crank case.

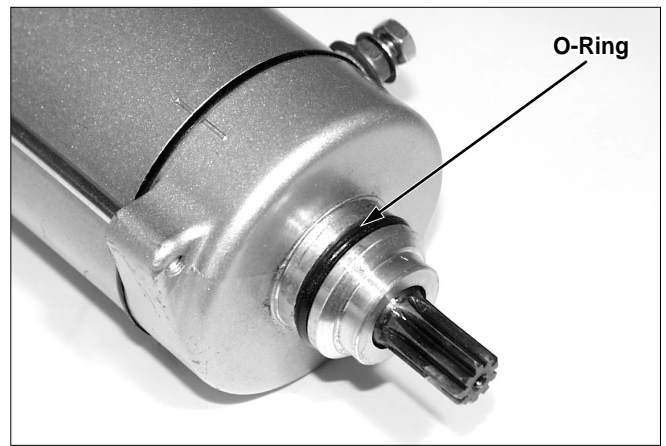

- Tighten the two mounting bolts securely.
- Install the starter motor cable, tighten the terminal nuts securely.

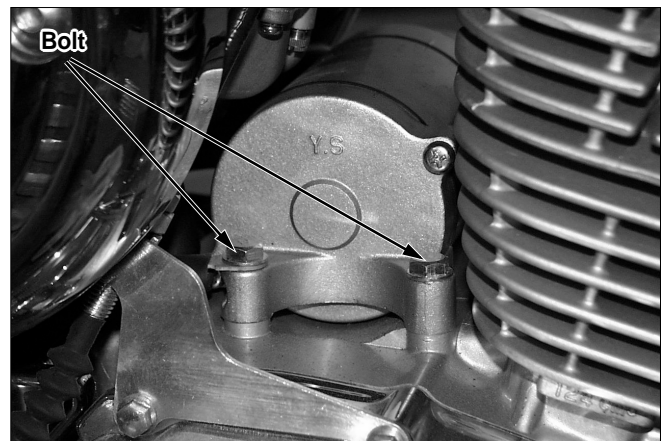

### Starter Magnetic Switch

#### Inspection

- Turn the main ignition switch "ON".
- There should be phonic signal in battery voltage while the starter magnetic switch is depressed.

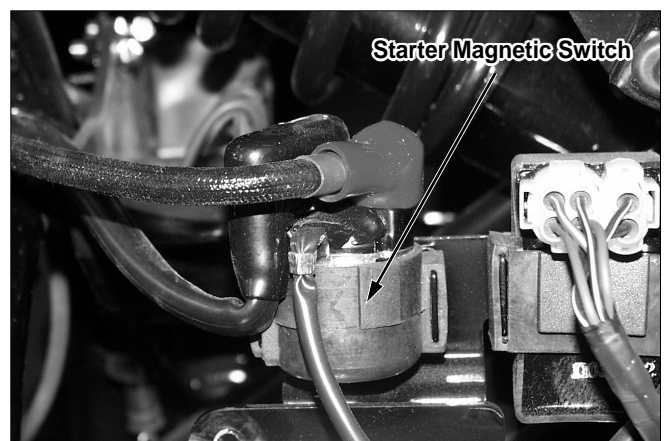

## Electric Starter

### Voltage Inspection

- Measure the voltage between the yellow/red wire  $\oplus$  of the starter magnetic switch and ground.
- Turn the main switch "ON". There should be battery voltage while the starter switch is depressed.

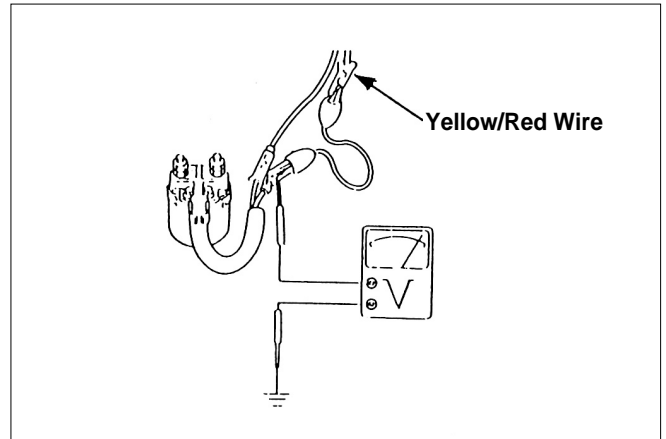

### Ground Circuit Inspection

- Disconnect the green/red wire connector of the starter magnetic switch.
- There should be continuity between the starter magnetic wire terminals at the harness side and ground.

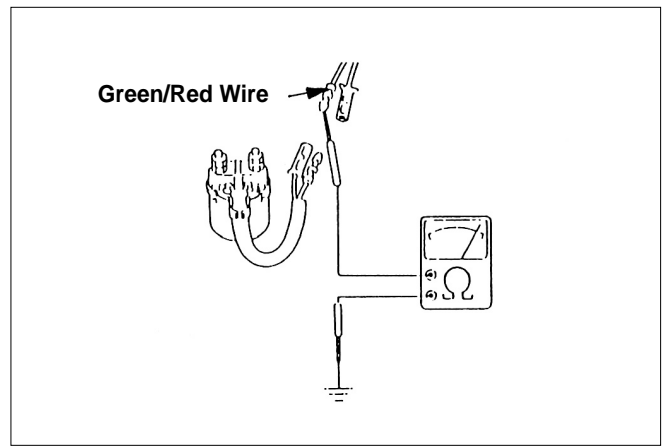

### Operation Inspection

- Disconnect the wire connector of the magnetic switch. Connect the positive wire to the yellow/red wire terminal and the negative wire to the green/red wire terminal and shown. There should be continuity.

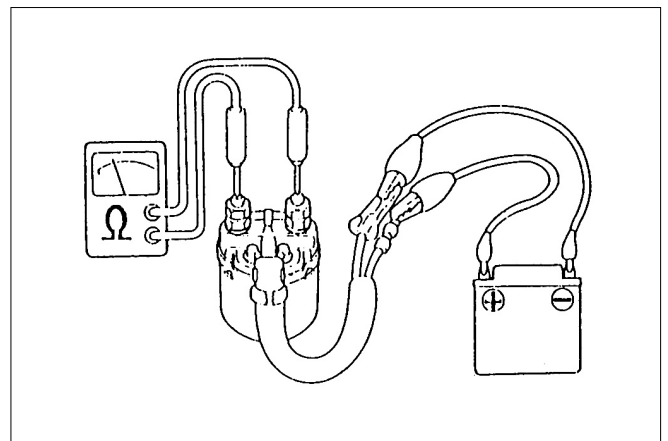



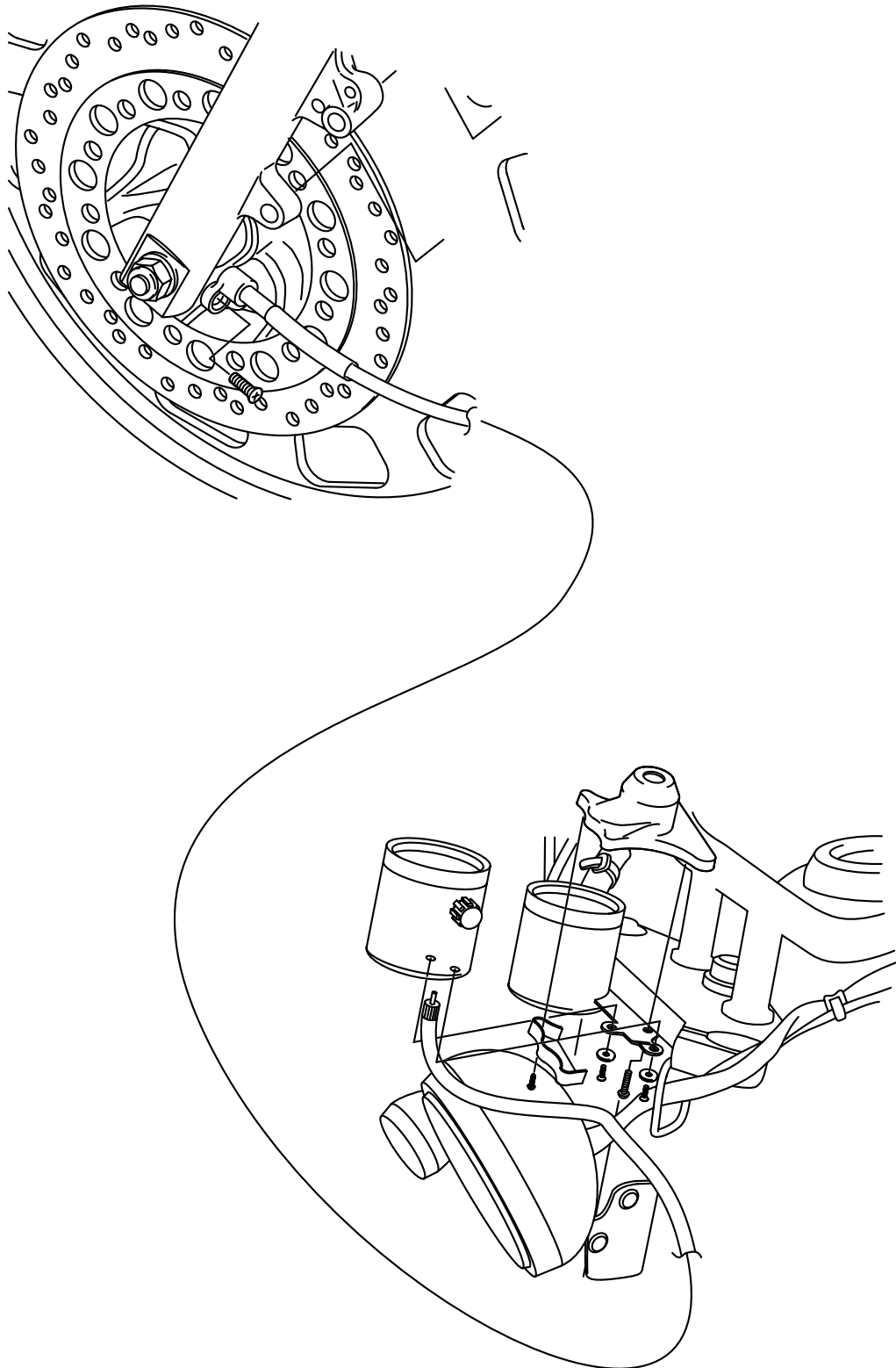

## 19. Lights/Switches/Horn

<b>Service Information</b> .....	<b>19-1</b>	<b>Main Switch</b> .....	<b>19-7</b>
<b>Troubleshooting</b> .....	<b>19-1</b>	<b>Handle Switch</b> .....	<b>19-8</b>
<b>Headlight</b> .....	<b>19-2</b>	<b>Gear Change Switch</b> .....	<b>19-9</b>
<b>Speedometer/Tachometer/Fuel Meter</b>	<b>19-2</b>	<b>Brake Light Switch</b> .....	<b>19-9</b>
<b>Tail/Brake Light</b> .....	<b>19-4</b>	<b>Horn</b> .....	<b>19-9</b>
<b>Winker Bulb</b> .....	<b>19-5</b>	<b>Fuel Unit</b> .....	<b>19-10</b>
<b>Winker Ass'y Removal</b> .....	<b>19-6</b>		

### Service Information

#### General

- Some wires have different colored bands around the near the connector. These are connected to order wires which have same colour band. Couplers are connected to order couplers which have same colour and same number of pins.
- All couplers have locking tabs that must be released before disconnecting and aligned when reconnecting.
- To isolate an electrical failure, check the continuity of the electrical path through the part. A continuity check can usually be made without removing the part from the motorcycle. Simply disconnect the wires and connect a continuity tester or volt-ohmmeter to th terminals or connections.
- In order to inspect that the electric continuity is between the secondary terminals, the continuity tester is needed. If the coil resistance is in circuit or if inspecting the high resistance by the corrosion of connecting part, the voit-ohmmeter is needed.

### Troubleshooting

#### No lighting-Main Switch turned ON

- Faulty bulb
- Faulty main switch
- Faulty wire connection
- Blown fuse
- Battery discharged

#### Dim headlight

- Battery discharged
- Wire, switch high resistance

#### Headlight: No high-low change

- Faulty bulb
- Faulty dimmer switch

## Headlight

### Removal

- Remove the two headlight mounting bolts and remove the headlight from the bracket.
- Remove the individual code from the wire.



### Bulb Replacement

- Remove the headlight rim and unit.
- Remove the spring.
- Remove the headlight socket and position light socket and replace the headlight bulb.



### Installation

- Install the headlight in the reverse order of removal.

#### ⚠ CAUTION

- Align the index mark on the headlight case with the index mark on the bracket.



## Speedometer/Tachometer/Fuelmeter

### Removal

- Loosen the speedometer cable nut and remove the cable from the meter.
- Remove the cable guide and meterstay from top bridge.
- Remove the seat and fuel tank, and separate the meter code from wire harness.



- Remove the combination switch upper/undercover.
- Remove the meter

### Installation

- Install the meter in the reverse order of removal

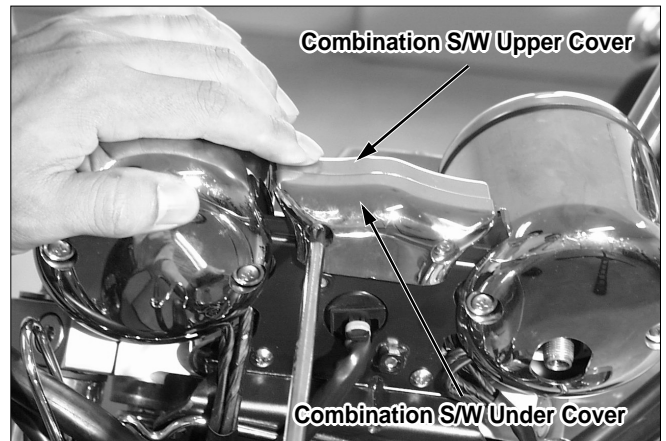

### Meter Bulb Replacement

- Loosen the 2 screw, and remove the speedometer.
- Loosen the 2 screw, and remove the tachometer.



- Take off the bulb socket, and replace the bulb.





### Fuel Meter Bulb Replacement

- Remove the hex socket bolt(3) of fuel meter.

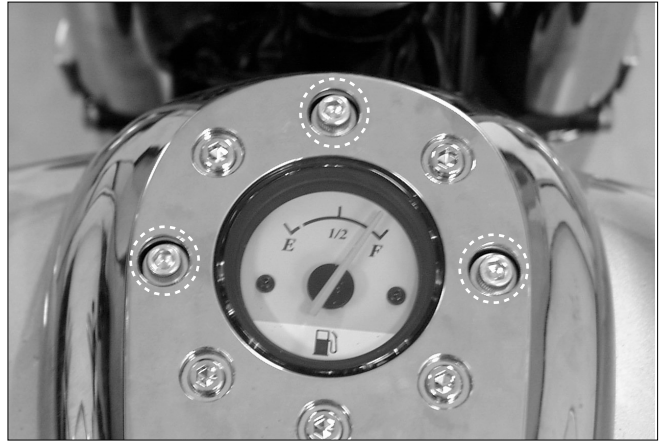

- Take off the bulb socket, and replace the bulb

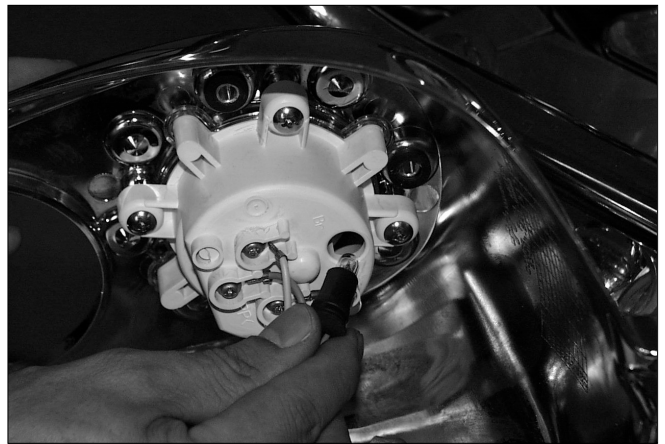

### Fuel Meter Removal

- Remove the headlight and remove the individual code from the case.
- Loosen the 4 Screw and remove the fuel meter from meter cover.
- Assembly is done in the reverse order of disassembly.

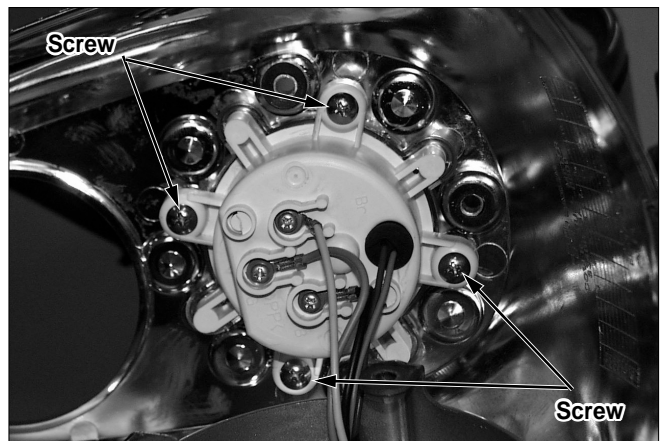

### Tail/Brake Light

- Loosen the 2 screw
- Remove the tail/brake light lens

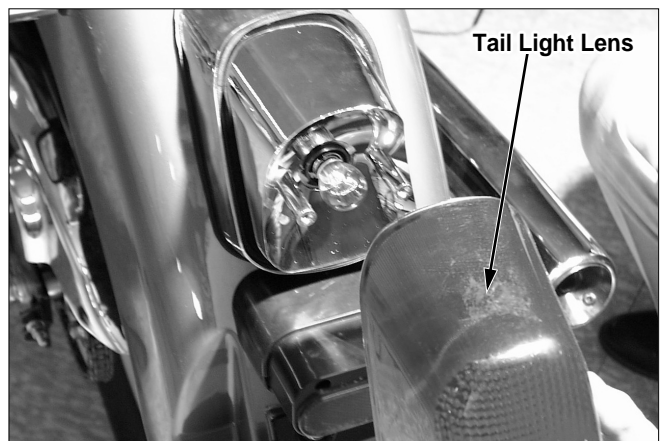

- Take off the bulb by turning toward anti-clockwise, and replace it.
- Assembly is done in the reverse order of disassembly.



## Winker Bulb

- Loosen the screw and remove the winker unit.
- Remove the bulb in bulb socket by turning toward anti-clockwise



- Pull out the bulb and replace.
- Assembly is done in the reverse order of disassembly.



## Winker Ass'y Removal

### Front

- Loosen the head light case screw (2 screws)
- Remove the winker connector connection in state of inclining for ward the head light lens.
- Remove the winker.

#### \* NOTE

- Place the wiring and cables exactly according to a wiring diagram.
- Installation is done in the reverse order of removal.

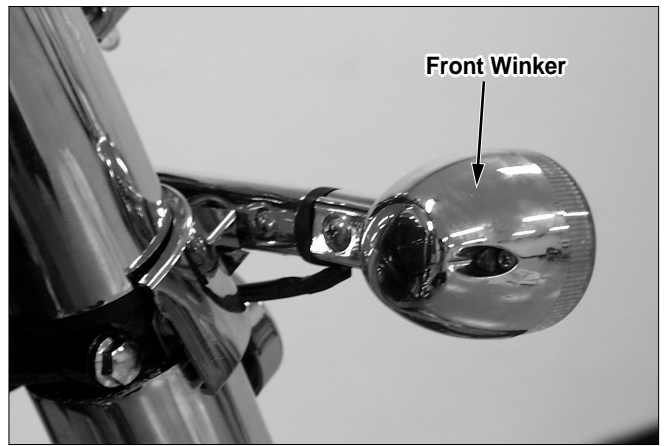

### Rear

- Remove the seat.
- Loosen the bolt and remove the winker connector connection.
- Remove the winker coupler socket/grab rail ass'y.
- Push the winker wire clamp and loosen the nut.
- Remove the winker coupler socket.
- Assembly is done in the reverse order of disassembly.

#### \* NOTE

- When assembling, align the projecting part the winker coupler socket with the grab rail groove.
- When installing, install the winker wire into the clamp of the grab rail exactly.
- Place the wire in exact position according to the intensity of wire.



## Main Switch

### Inspection

- Remove the fuel tank. Disconnect the main switch code coupler connection. Check for continuity between terminals in each switch position. There should be a continuity between the colour coded wire. (○—○)

	IG	E	BAT <sub>1</sub>	BAT <sub>2</sub>
OFF	○—○			
ON			○—○	
Color Code	Black/White	Green	Red	Black

### Removal

- Remove the combination switch upper/under cover.
- Remove the 4 tapping screw from the meter stay.
- Remove the main switch coupler.
- Remove the main switch

### Installation

- Install the main switch in the reverse order of removal.

### Engine Stop Switch

- When happening the urgent situation during driving, it is equipment for operating the engine stop to “OFF” position and braking the engine.

#### ⚠ CAUTION

- After checking for being “RUN” position before starting, start the main switch in “ON” position.

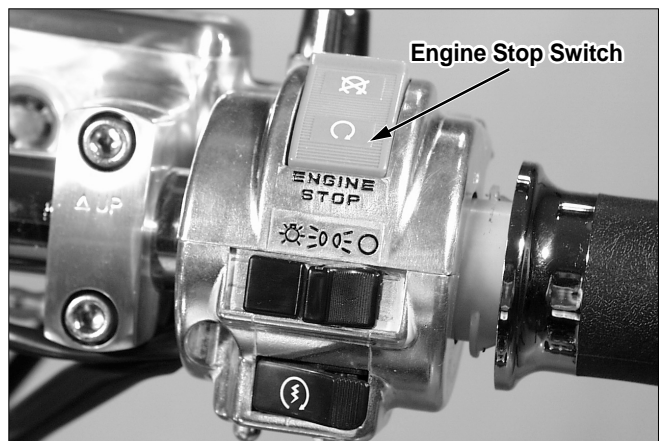

## Handle Switch

- Remove the headlight case.
- Disconnect the handle bar switch couplers /connectors.
- Check for continuity between wire terminals. Continuity should exist between the colour coded wires o-o in each switch position.
- If the continuity is between o-o, it is correct.

### Starter Switch

	ST <sub>1</sub>	ST <sub>2</sub>
Free		
Push	○	○
Color Code	Black/Green	Yellow/Red

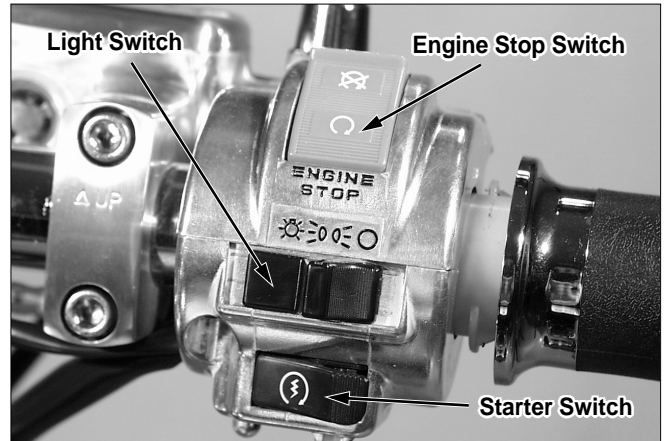

### Light Switch

	BAT	TL	HL
OFF			
P	○	○	
H	○	○	○
Color Code	Black	Brown	Blue/White

### Winker Switch

	R	W	L
R	○	○	
N			
L		○	○
Color Code	Sky Blue	Gray	Orange

### Dimmer Switch

	HI	HL	LO
LO		○	○
HI	○	○	
Color Code	Blue	Blue/White	White

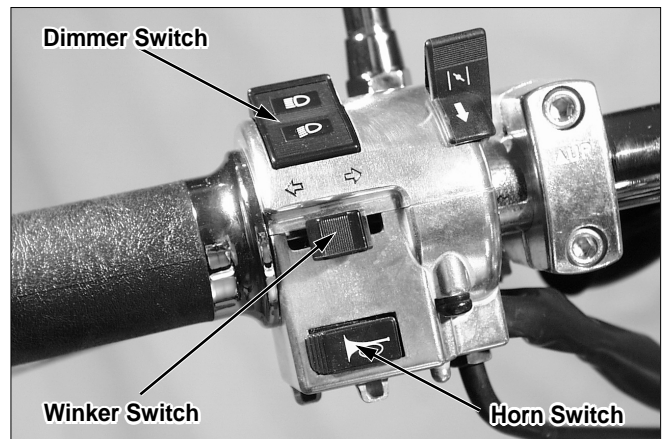

### Horn Switch

	HO	BAT
Free		
Push	○	○
Color Code	Light Green	Black

### Engine Stop Switch

	EXT	E	BAT <sub>2</sub>	ST <sub>1</sub>
RUN			○	○
OFF	○	○		
Color Code	Black/White	Green	Black	Black/Green

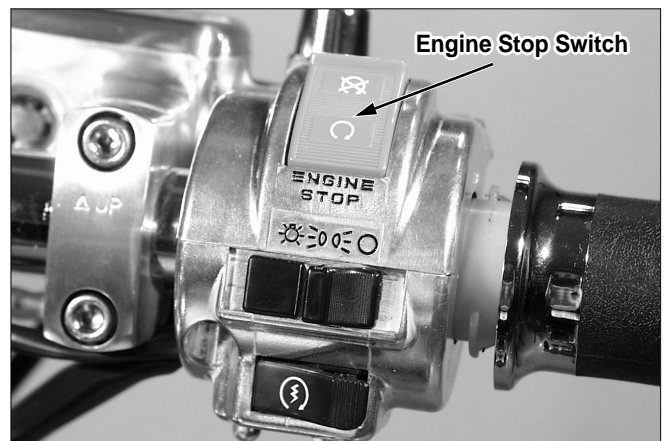

## Gear Chain Switch

- Disconnect the gear change switch wire coupler.
- Check for the continuity between the terminal and engine ground.

Gear Position	Terminal
Neutral	Light green/Red



## Brake Light Switch

### Front

- Remove the headlight case.
- Disconnect the front brake light switch wire connectors and check for continuity between the connector terminals. The switch should have continuity with the front brake applied and no continuity with it released.

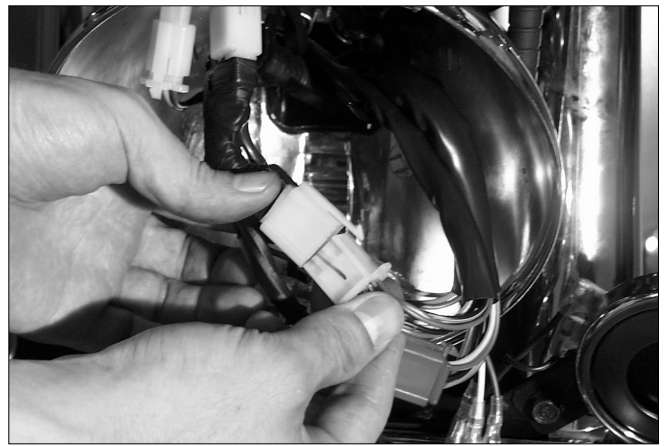

### Rear

- Remove the R. side cover. (⇒12-2)
- Disconnect the rear brake light switch wire coupler and check for continuity between terminals.
- The switch should have continuity with the rear brake applied and no continuity with it released.



## Horn

- Remove the wire connector from the horn.

### ⚠ CAUTION

- The horn is consisted of the high horn and the low horn. Install the high horn on the left side and the low horn on the right side in case of replacement.



## Lights/Switches/Horn

- The horn should sound when a fully charge 12V battery is connected across the horn terminals.

## Fuel Unit

- Remove the fuel tank.
- Drain fuel out of tank at clean container.
- Loosen the 4 nuts and remove the fuel unit from tank.

### ⚠ CAUTION

- Be careful float arm is not bended

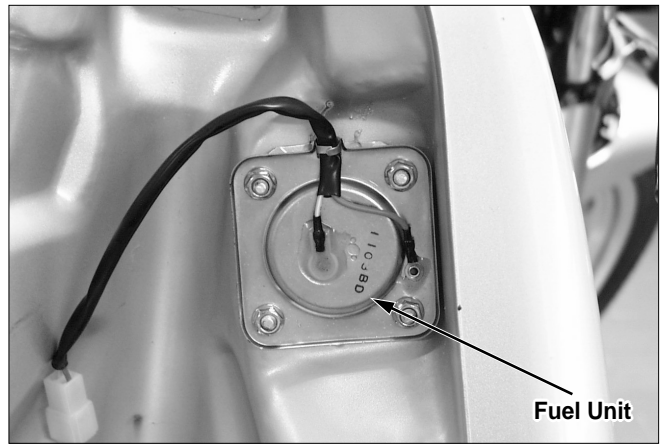

## Unit Inspection

- Measure the resistance between both terminals moving float up and down.

Float Position	Resistance
High	0.02~0.1 Ω
Low	13~25.5 Ω

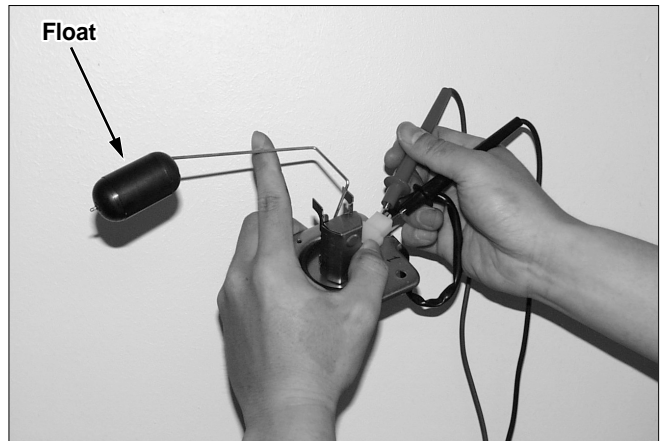

## Fuel Meter Inspection

- Connect wire coupler of fuel unit and put the main switch on.
- Check the position of the meter indicator moving float up and down.

Float Position	Resistance
High	F 측
Low	E 측

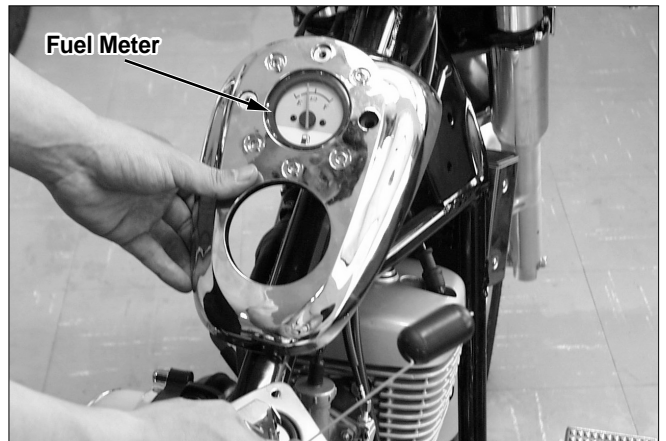

# 20. Wiring Diagram

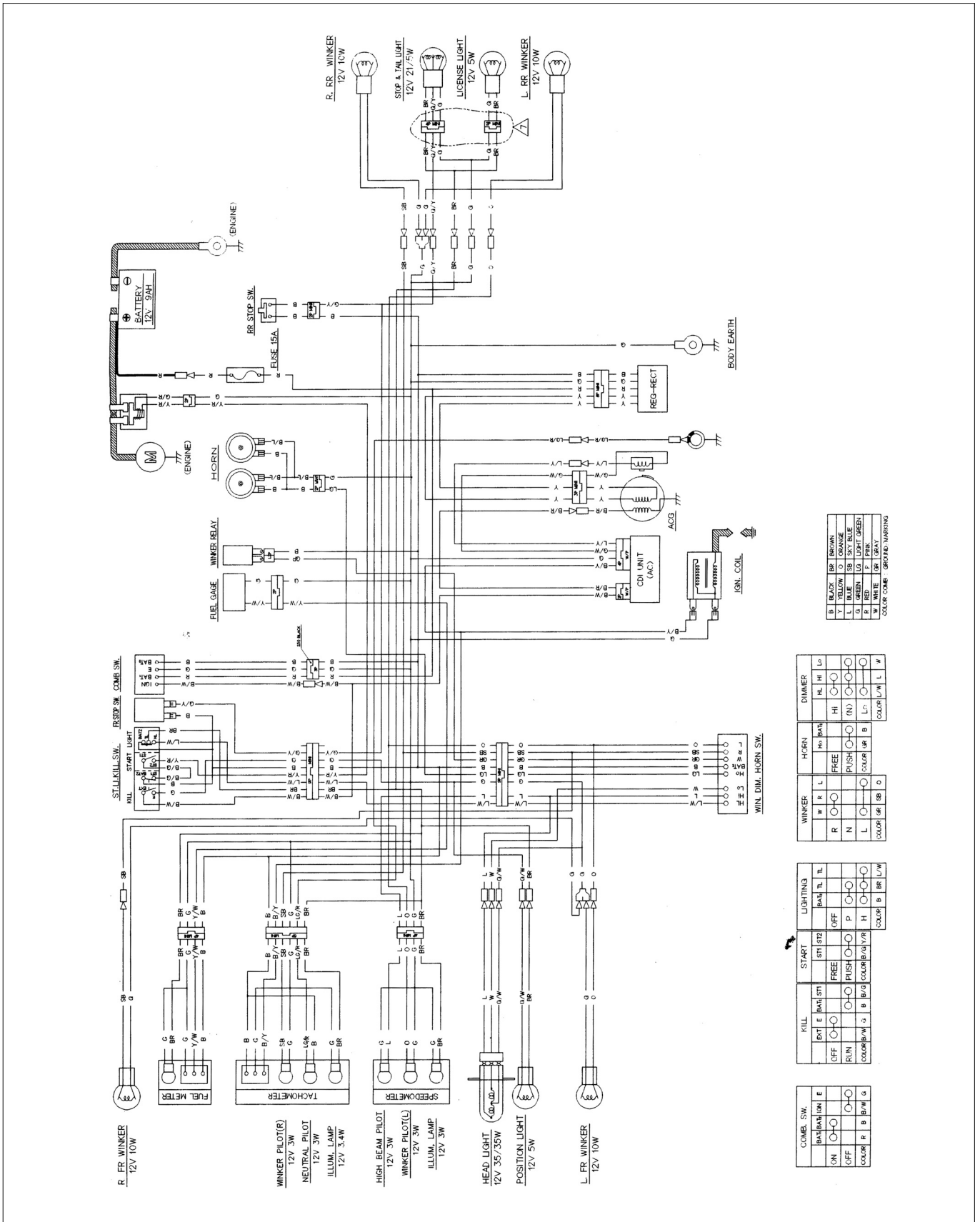





## 21. Troubleshooting

<b>Engine Does Not Starter is Hard to Start</b> .....	<b>21-1</b>
<b>Engine Lacks Power</b> .....	<b>21-2</b>
<b>Poor Performance(At Low and Idle Speeds)</b> .....	<b>21-3</b>
<b>Poor Performance (At High speed)</b> .....	<b>21-4</b>
<b>Poor Handling</b> .....	<b>21-4</b>

### Engine Doesn't Start or is Hard to Start



## Engine Lacks Power

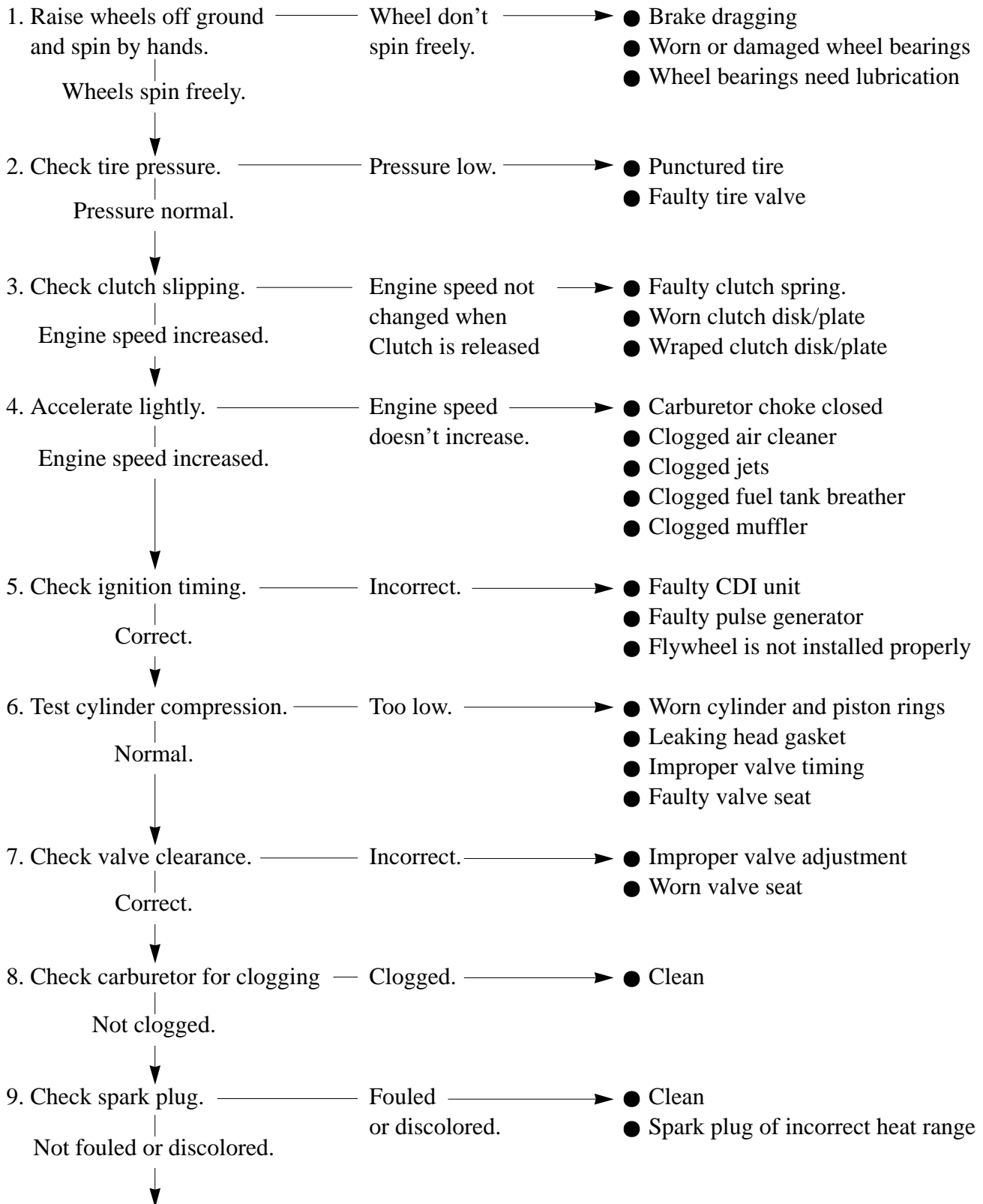

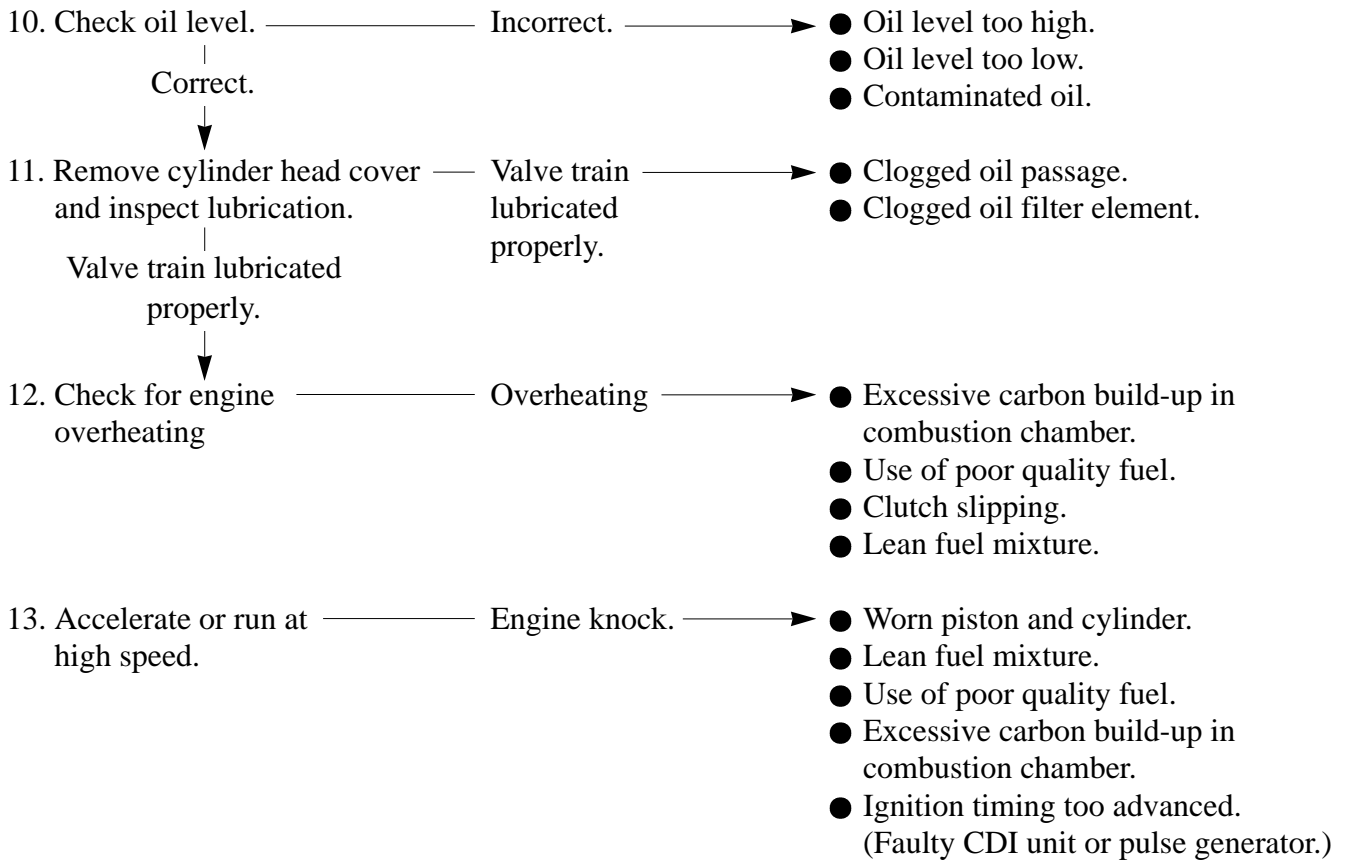

## Poor Performance(At Low and Idle Speed)

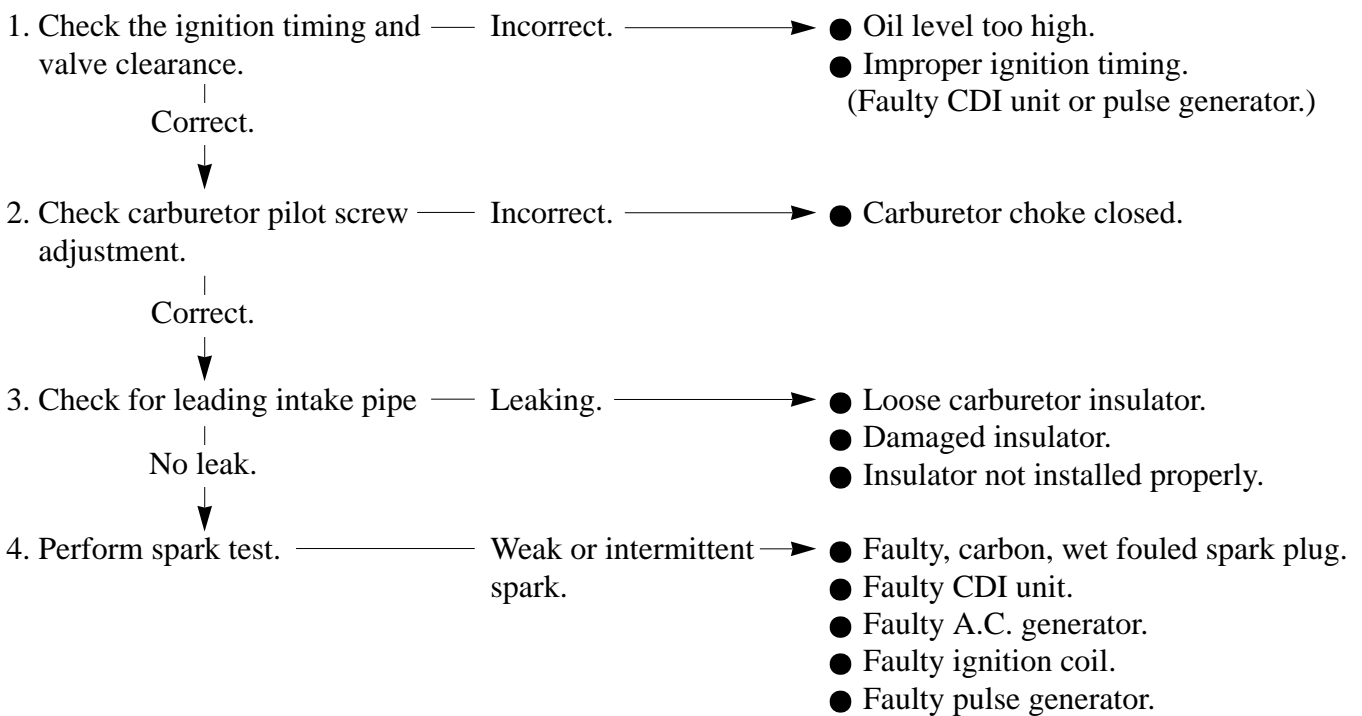

## Poor Performance(At High Speed)

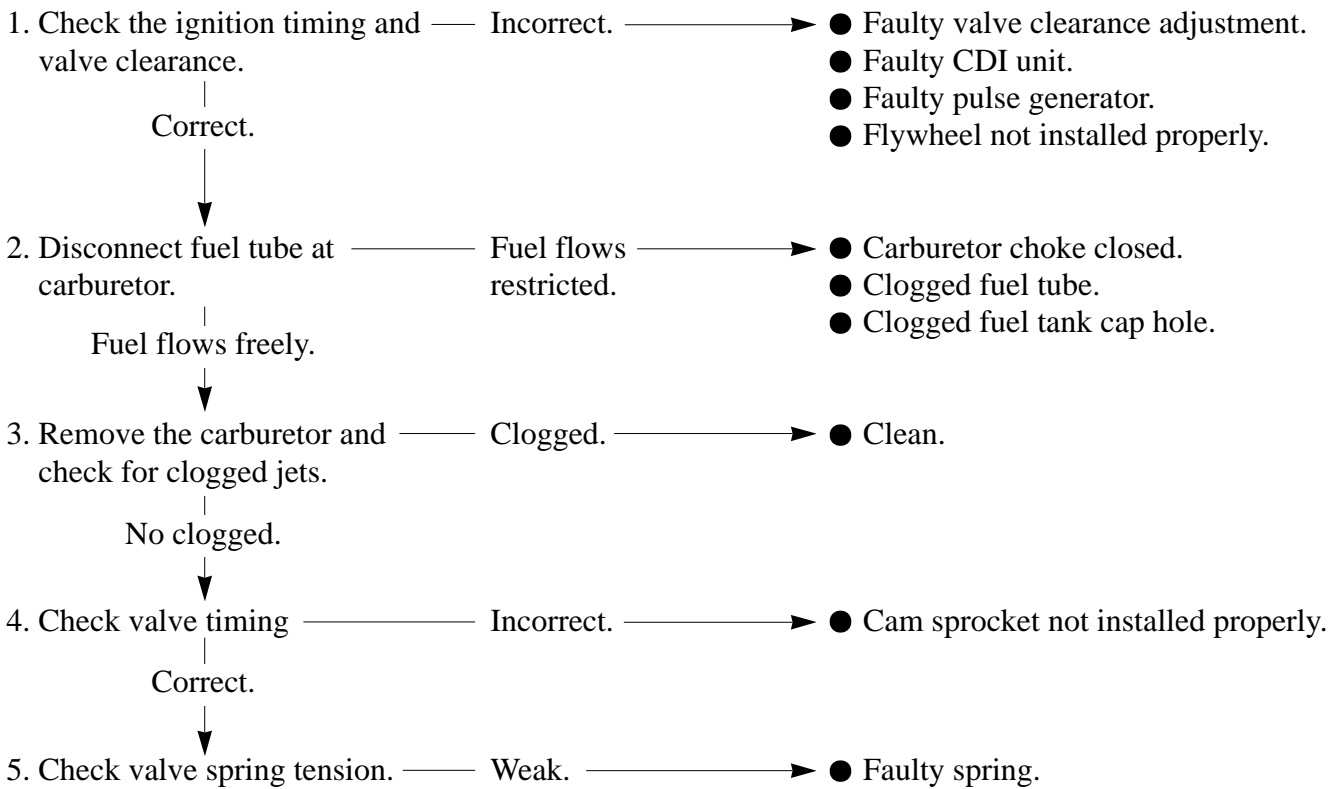

## Poor Performance(At High Speed)

1. If steering is heavy. → ● Too tight steering top thread.  
● Damaged steering bearings.
2. If front wheel or rear wheel is wobbling → ● Excessive wheel bearing play.  
● Bent rim.  
● Improperly installed wheel hub.  
● Worn rear fork pivot bush.  
● Bent frame.  
● Rear fork pivot adjusting bolt is too tight.
3. If the motorcycle pulls to one side. → ● Front and rear wheels are not aligned.  
● Bent front fork.  
● Bent rear fork.



**DAELIM MOTOR CO.,LTD.**

---

- HEAD OFFICE:#16-6 PIL-DONG 2KA, CHUNG-KU, SEOUL, KOREA  
TEL:(82-2) 2267-6111 / FAX:(82-2) 2269-7997
- FACTORY:#58, SUNG SAN-DONG, CHANG WON, KYUNGNAM, KOREA  
TEL:(82-551) 279-1000 / FAX:(82-551) 263-9761